

Workshop manual

Group 20-23, 26, 30

A
2(0)

D2-55, D2-75

Marine engine

D2-55 A/B/C • D2-75 A

Contents

Safety Precautions	2	Valve lifters, inspection	47
General information	5	Valves, adjustment	49
Special tools	9	Flywheel, replace ring gear	49
Design and function	10	Crankshaft seal, rear, replace	50
Location of engine type signs	10	Crankshaft seal, front, replace	50
Engine introduction	11	Group 22: Lubrication system	
Component description	16	Oil pump	51
Repair instructions	23	Oil channels	54
General	23	Oil pump bearing, overhaul	55
Engine fixture, fixing	24	Group 23: Fuel system	
Compression test	24	Injection pump	56
Group 21: Short block		Setting injection timing	57
Short block, disassembly	25	Setting the engine speed	59
Inspecting the engine block	29	Feed pump	60
Upper block plane	29	Venting the fuel system	61
Cylinder bore	29	Fuel filter, replace	63
Cylinder head, overhaul	30	Fuel pre-filter, drain and replace	63
Cylinder head, disassembly	30	Injectors	64
Cylinder head, inspection	30	Group 26: Cooling system	
Valve seat, replace	31	Fresh water system	67
Valves and valve seats, grinding	31	Coolant	68
Valve guides, check	32	Draining coolant	69
Rocker arm mechanism, overhaul	33	Filling with coolant	69
Cylinder head, assembly	33	Checking the coolant level	70
Crankshaft, inspection	34	Cleaning heat exchanger	71
Main and big-end bearings, inspection	34	Circulation pump	72
Crankshaft bush, front, inspection	35	Sea water pump	73
Crankshaft bush, front, replace	35	Thermostat	73
Crank bearing play, check	36	Group 30: Electrical system	
Piston rings, inspection and adjustment	37	Description	74
Piston and cylinder bore, inspection and measurement	37	Important information concerning the electrical system	76
Con rods, inspection	38	Fault tracing, glow plugs, charging system	78
Con rod bush, replace	38	Alternator	82
Piston, piston rings and con rods, installation	39	Starter motor	86
Camshaft, measurement	40	Electrical components	89
Timing gear assembly, inspection	40	Wiring diagrams	92
Crankshaft, installation	40	Group 20: Technical data	
Piston, installation in cylinder	41	Technical data	96
Camshaft, installation	42	Wear tolerances	100
Cylinder head, installation	44	Tightening torque	101

Safety Precautions

Introduction

This Service Manual contains technical data, descriptions and repair instructions for the Volvo Penta products or product versions noted in the table of contents. Check that you have the correct Workshop Manual for your engine.

Read the available safety information, General Information and Repair Instructions in the Service Manual before you start to do any service work.

Important

In this book and on the product you will find the following special warning symbols.

 **WARNING!** Possible danger of personal injury, extensive damage to property or serious mechanical malfunction if the instructions are not followed.

 **IMPORTANT!** Used to draw your attention to something that can cause damage or malfunctions on a product or damage to property.

NOTE! Used to draw your attention to important information that will facilitate the work or operation in progress.

Below is a summary of the risks involved and safety precautions you should always observe or carry out when operating or servicing the engine.

 Immobilize the engine by turning off the power supply to the engine at the main switch (es) and lock it (them) turned off before starting work. Set up a warning notice by the helm station.

 As a general rule all service operations must be carried out with the engine stopped. Some work, such as adjustments, need the engine to be running, however. Approaching an engine which is running is a safety risk. Remember that loose clothing or long hair can fasten in rotating parts and cause serious personal injury.

If work is done adjacent to a running engine, a careless movement or a dropped tool can lead, in the worst case, to personal injury. Be careful with hot surfaces (exhaust pipes, turbos, charge air pipes, starting heaters etc.) and hot fluids in pipes and hoses on an engine which is running or which has just stopped. Always refit shields that have been removed for service work before starting the engine.

 Check that the warning or information labels on the product are always clearly visible. Replace labels which have been damaged or painted over.

 Never start the engine without installing the air cleaner filter. The rotating compressor turbine in the turbocharger can cause severe injury. Foreign objects entering the intake ducts can also cause mechanical damage.

 Never use start spray or similar products as a starting aid. They may cause an explosion in the inlet manifold. Danger of personal injury.











 Avoid opening the coolant filling cap when the engine is hot. Steam or hot coolant can spray out and the system pressure will be lost. Open the filler cap slowly, and release the pressure in the cooling system if the filling cap or tap has to be opened, or if a plug or coolant hose has to be removed when the engine is hot. Steam or hot coolant might spray out in an unexpected direction.





 Hot oil can cause burns. Avoid skin contact with hot oil. Ensure that the lubrication system is not under pressure before carrying out any work. Never start or operate the engine with the oil filler cap removed, otherwise oil could be ejected.

 Stop the engine and close the sea cocks before doing any work on the cooling system.

 Only start the engine in a well-ventilated area. When operated in a confined space, exhaust fumes and crankcase gases must be ventilated from the engine bay or workshop area.

 Always use protective glasses or goggles when carrying out work where there is a risk of splinters, grinding sparks, acid splashes or where other chemicals are used. Your eyes are extremely sensitive, injury could cause blindness!

-  Avoid getting oil on your skin! Repeated exposure to oil or exposure over a long period can result in the skin becoming dry. Irritation, dryness and eczema and other skin problems can then occur.
- Used oil is more dangerous than fresh oil from a health aspect. Use protective gloves and avoid oil-soaked clothes and rags. Wash regularly, especially before eating. There are special skin creams which counteract drying out of the skin and make it easier to clean off dirt after work is completed.
-  Most chemicals intended for the product (e.g. engine and transmission oils, glycol, petrol (gasoline) and diesel oil) or chemicals for workshop use (e.g. degreasers, paints and solvents) are hazardous. Read the instructions on the product packaging with care! Always follow the safety precautions for the product (for example use of protective mask, glasses, gloves etc.). Make sure that other personnel are not inadvertently exposed to hazardous chemicals, for example in the air. Ensure good ventilation in the work place. Follow the instructions provided when disposing of used or leftover chemicals.
-  Exercise extreme care when leak detecting on the fuel system and testing the fuel injector nozzles. Use eye protection. The jet from a fuel nozzle has very high pressure and great penetration power. Fuel can force its way deep into body tissue and cause severe injury. Danger of blood poisoning (septicemia).
-  All fuels, and many chemicals, are flammable. Do not allow naked flame or sparks in the vicinity. Petrol (gasoline), some thinners and hydrogen gas from batteries are extremely flammable and explosive when mixed with air in the correct ratio. No Smoking! Ensure that the work area is well ventilated and take the necessary safety precautions before starting welding or grinding work. Always ensure that there are fire extinguishers at hand when work is being carried out.
-  Make sure that oil and fuel soaked rags, and used fuel and oil filters are stored in a safe place. Rags soaked in oil can spontaneously ignite under certain circumstances. Used fuel and oil filters are polluting waste and must be handed to an approved waste management facility for destruction, together with used lubrication oil, contaminated fuel, paint residue, solvents, degreasers and wash residue.
-  Never expose a battery to naked flame or electrical sparks. Never smoke close to the batteries. The batteries generate hydrogen gas when charged, which forms an explosive gas when mixed with air. This gas is easily ignited and highly volatile. A spark, which can be caused by incorrect battery connection, can cause a single spark which is sufficient to cause an explosion with resulting damage. Do not move the connections when you attempt to start the engine (risk of arcing), and do not stand and lean over one of the batteries.
-  Always ensure that the Plus (positive) and Minus (negative) battery cables are correctly installed on the corresponding terminal posts on the batteries. Incorrect installation can result in serious damage to the electrical equipment. Refer to the wiring diagram.
-  Always use protective goggles when charging and handling the batteries. Battery electrolyte contains sulfuric acid which is highly corrosive. Should the battery electrolyte come into contact with unprotected skin wash off immediately using plenty of water and soap. If you get battery acid in your eyes, flush at once with a generous amount of water, and get medical assistance at once.
-  Turn the engine off and turn off the power at the main switch(es) before carrying out work on the electrical system.
-  Clutch adjustments must be carried out with the engine stopped.
-  The existing lugs on the engine/reversing gear should be used for lifting the assembly. Always check that the lifting equipment used is in good condition and has the load capacity to lift the engine (engine weight including gearbox, if fitted, and any extra equipment). Use an adjustable lifting beam or lifting beam specifically for the engine to raise the engine to ensure safe handling and to avoid damaging engine parts installed on the top of the engine. All chains and cables should run parallel to each other and as perpendicular as possible in relation to the top of the engine. If other equipment connected to the engine has altered its center of gravity, special lifting devices may be needed to obtain the correct balance and safe handling. Never carry out work on an engine suspended on a hoist.

-  Never work alone when removing heavy engine components, even when using lifting devices such as locking tackle lifts. When using a lifting device two people are usually required to do the work, one to take care of the lifting device and another to ensure that components are lifted clear and not damaged during the lifting operations.
When you work aboard a boat, always make sure that there is enough space for disassembly where you are working, with no risk of personal injury or damage to materials.
-  Components in the electrical and fuel systems on Volvo Penta products have been designed to minimize the risks of explosion and fire. The engine must not be run in areas where there are explosive materials.
-  Fuel delivery pipes must not be bent or straightened under any circumstances. Damaged pipes must be replaced.
-  Remember the following when washing with a power washer: Never aim the water jet at seals, rubber hoses or electrical components. Never use a power washer for engine cleaning.
-  Only use the fuels recommended by Volvo Penta. Refer to the Operator's Manual. Use of fuels that are of a lower quality can damage the engine. On a diesel engine, poor quality fuel can cause the control rod to bind and the engine to over-rev with resulting risk of damage to the engine and personal injury. Poor fuel can also lead to higher service costs.

General information

About this Service Manual

This Service Manual contains technical data, descriptions and repair instructions for the standard version of engine unit D2-55.

The Service Manual can illustrate tasks done on any of the engines noted above. This means that the illustrations and photographs which clarify certain details might not correspond with other engines in some cases. Repair methods are however in general, identical. If this is not the case, this will be noted and important differences will be shown separately. The engine designation and engine number are given on a type plate (see page 14). The engine designation and number must always be given in all correspondence about an engine.

The Service Manual is produced primarily for the use of Volvo Penta workshops and service technicians. This assumes that people who use the Manual have basic knowledge of marine drive systems and can do the tasks of a mechanical or electrical nature associated with the trade.

Volvo Penta constantly improves its products, so we reserve the right to make modifications without prior notification. All information in this manual is based on product data which was available up to the date on which the manual was printed. Any material changes introduced into the product or service methods after this date are notified by means of Service Bulletins.

Spare parts

Spare parts for electrical and fuel systems are subject to various national safety requirements such as the US Coast Guard Safety Regulations. Volvo Penta Original Spare Parts meet these specifications. No damage whatever, occasioned by use of non-original Volvo Penta spares for the product, will be compensated by the warranty offered by Volvo Penta.

Certified engines

When doing service and repair on emission certified engines, it is important to be aware of the following:

Certification means that an engine type has been checked and approved by the relevant authority. The engine manufacturer guarantees that all engines made of the same type are equivalent to the certified engine.

This makes special demands on service and repair work, as follows:

- Care and Service intervals recommended by Volvo Penta must be followed.
- Only Volvo Penta original spare parts may be used.
- Service to injection pumps, pump settings and injectors must always be performed by an authorized Volvo Penta workshop.
- The engine must not be converted or modified, except for the accessories and service kits that Volvo Penta has approved for the engine.
- No installation changes to the exhaust pipe and engine air inlet ducts may be made.
- Any anti-tamper seals on the engine may not be broken by unauthorized persons.

The general advice in the instruction book about operation, care and maintenance, applies.



IMPORTANT! Neglected or poorly performed care/service, as well as use of non-original spare parts, entails that AB Volvo Penta can no longer guarantee that the engine conforms to the certified model.

Damage, injury and/or costs which arise from this will not be compensated by Volvo Penta.

Repair procedures

The working methods described in the Service Manual apply to work carried out in a workshop. For this reason, the engine is lifted out of the boat and mounted on an engine support. Renovation work which does not need the engine to be lifted out can be done in situ, with the same work methods, unless otherwise specified.

Warning symbols used in this Service Manual (for full explanation of the symbols refer to the section; "Safety Precautions")

 **WARNING!**

 **IMPORTANT!**

NOTE!

are not in any way comprehensive since it is impossible to predict every circumstance under which service work or repairs may be carried out. For this reason, all we can do is to point out the risks which we believe could occur due to incorrect work in a well-equipped workshop, using work methods and tools tested by us.

All operations described in the Service Manual for which there are Volvo Penta Special Tools available assume that these tools are used when carrying out the repair. Volvo Penta Special Tools have been specifically developed to ensure the most safe and rational working methods possible. It is therefore the responsibility of anyone using other tools or other working methods than we recommend to determine that there is no risk of personal injury or mechanical damage or malfunction as a result.

In some cases special safety precautions and user instructions may be required in order to use the tools and chemicals mentioned in the Service Manual. These rules must always be observed, so there are no special instructions about this in the Service Manual.

By following these basic recommendations and using common sense it is possible to avoid most of the risks involved in the work. A clean workplace and a clean engine will eliminate many risks of personal injury and engine malfunction.

Above all, when work on fuel systems, lubrication systems, induction systems, turbocharger, bearing caps and seals is done, it is extremely important that no dirt or other kinds of foreign particles are able to get in, since this would otherwise cause malfunctions or shortened repair life.

Our common responsibility

Each engine consists of a large number of collaborating systems and components. Any deviation of a component from its technical specification can dramatically increase the environmental impact of an otherwise good engine. For this reason, it is extremely important that specified wear tolerances are maintained, that systems with adjustment facilities are correctly adjusted and that Volvo Penta Original Spares are used for the engine. The stated service intervals in the Maintenance Schedule must be observed.

Some systems, such as the components in the fuel system, require special expertise and special testing equipment for service and maintenance. Some components are sealed at the factory, for environmental reasons etc. It is only permissible to work on sealed components if you are authorized to do such work.

Remember that most chemical products, incorrectly used, damage the environment. Volvo Penta recommends the use of biodegradable degreasers whenever engine components are de-greased, unless otherwise specified in the Service Manual. When working aboard a boat, be careful to ensure that oils, wash residue etc. are processed for destruction, and are not inadvertently discharged with bilge water into the environment.

Tightening torque

The tightening torque for critical joints that shall be tightened with a torque wrench, are listed in "Specifications: Tightening torque" and noted in the job descriptions in the book. All torque specifications apply to clean screws, screw heads and mating faces. Torque data stated apply to lightly oiled or dry threads. Where grease, locking or sealing agents are required for screwed joints, this is stated in both the operation description and in "Torque". Where a particular torque value is not specified for any fastener, the general tightening torque in the table below shall apply. The torque specification is a target value and the fastener does not need to be tightened with a torque wrench.

Dimension	Tightening torque	
	Nm	lbf.ft
M5	6	4.4
M6	10	7.4
M8	25	18.4
M10	50	36.9
M12	80	59.0
M14	140	103.3

Torque-angle tightening

With torque/angle tightening, the fastener is tightened to the specified torque, and tightening then continues through a pre-determined angle. Example: for 90° angle tightening, the fastener is turned a further 1/4 turn in one sequence, after the specified tightening torque has been achieved.

Lock nuts

Disassembled locknuts shall not be re-used, they shall be replaced by new ones, since the locking properties are impaired or lost when the nut is used several times. For locknuts with plastic inserts, i.e. Nylock® the tightening-torque given in the table shall be reduced if the Nylock®-nut has the same nut height as a standard all-metal hex-nut. Reduce the torque by 25% for screw size 8 mm or larger. Where Nylock® nuts are higher, i.e. the metallic thread is of the same height as a standard hexagonal nut, the torque given in the table apply.

Strength classes

Screws and nuts are sub-divided into different strength classes. Classification is indicated by markings on the screw head. A marking with higher number indicates stronger material. For example, a screw marked 10-9 is stronger than one marked 8-8. For this reason, when fasteners are removed, it is important that the screws are put back in the correct places when they are re-installed. If a screw must be replaced, check in the spare parts catalogue to make sure the correct screw is used.

Sealant

Several different types of sealant and locking fluids are used on the engine. The properties of the preparations differ, and they are intended for different strengths of fastener, temperature, resistance to oil and other chemicals, and for the different materials and gap thicknesses found in the engine.

To ensure service work is correctly carried out it is important that the correct sealant and locking fluid type is used on the joint where the agents are required.

In this Service Manual, the user will find that each section where these agents are applied in production states which type was used on the engine.

In service work, the same preparations or preparations of corresponding properties, but of other makes, shall be used.

When sealants and locking fluids are used, it is important that the surfaces are free from oil, grease, paint and rust-protection, and that they are dry.

Always follow the manufacturer's instructions for use regarding temperature range, curing time and any other instructions for the product.

Two different basic types of agent are used on the engine. These are:

RTV preparations (Room Temperature Vulcanizing). Used for gaskets, sealing gasket joints or coating gaskets. RTV is visible when a part has been disassembled; old RTV must be removed before resealing the joint.

The following RTV preparations are mentioned in the workshop manual: Loctite® 574, Silicone GE RTV1473W, Permatex® No. 3, Volvo Penta 1161099-5, Permatex® No 77. Old sealant can be removed using denatured alcohol in all cases.

Anaerobic agents. These agents cure in the absence of air. These preparations are used when two solid components, such as two cast components, are fitted together without a gasket. Common uses are also to lock and seal plugs, stud threads, taps, oil pressure monitors etc. Hardened anaerobic preparations are glassy and for this reason, the preparations are colored to make them visible. Hardened anaerobic preparations are highly resistant to solvents, and old compound can not be removed. On re-installation, degrease carefully and then apply new sealant.

The following anaerobic preparations are mentioned in the workshop manual: Loctite® 572 (white color).

NOTE: Loctite® is a registered trademark belonging to the Loctite Corporation, Permatex® is a registered trademark belonging to the Permatex Corporation.

Safety rules for Fluorocarbon rubber

Fluorocarbon rubber is a common material in seal rings for shafts, and in O-rings, for example.

When fluorocarbon rubber is subjected to high temperatures (above 300°C), **hydrofluoric acid** can be formed, which is highly corrosive. Contact with the skin can result in severe chemical burns. Splashes in your eyes can result in severe chemical burns. If you breathe in the fumes, your lungs can be permanently damaged.



WARNING! Be very careful when working on engines which have been exposed to high temperatures, e.g. overheating during a seizure or fire. Seals must never be cut with a flame torch during disassembly, or burned in uncontrolled circumstances afterwards.

- Always use gloves made of chloroprene rubber (gloves for handling chemicals) and protective goggles.

- Handle the removed seal in the same way as corrosive acid. All residue, including ash, can be highly corrosive. Never use compressed air to blow anything clean.
- Put the remains in a plastic jar which is sealed and provided with a warning label. Wash the gloves under running water before removing them.

The following seals are most probably made from fluorocarbon rubber:

Seal rings for the crankshaft, camshaft and drive shafts.

O-rings, regardless of where they are installed. O-rings for cylinder liner sealing are almost always made of fluorocarbon rubber.

Note that seals which have not been subjected to high temperature can be handled normally.

Special tools

Wherever feasible, the tool numbers have been punched on the tools.

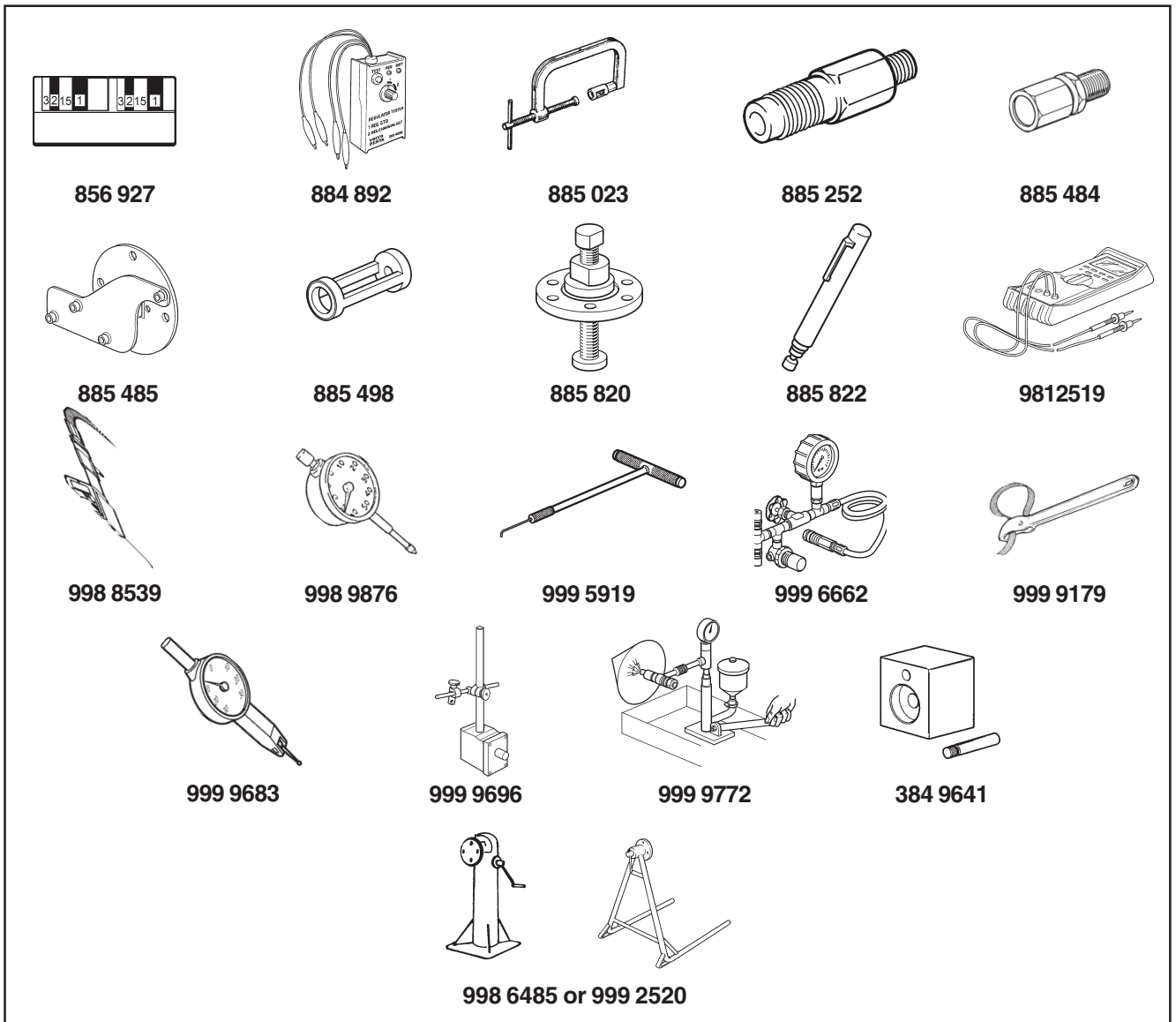

- 856 927** Plastigauge, for measuring main and big-end bearing play
- 884 892** Regulator tester
- 885 023** Valve spring compressor
- 885 252** Adapter for testing compression pressure
- 885 484** Adapter for testing compression pressure
- 885 485** Engine fixture for overhaul stand
- 885 820**¹⁾ Puller for pulleys
- 885 822** Magnetic pen
- 885 498** Pressure foot (used together with valve spring compressor 885 023)

- 981 2519** Multimeter
- 998 8539** Compression tester
- 998 9876** Dial indicator
- 999 5919** Puller, seals
- 999 6662** Pressure testing equipment
- 999 9179** Wrench for removing fuel/oil filters
- 999 9684** Rocker indicator
- 999 9696** Magnetic stand
- 999 9772** Injector tester
- 384 9641** Assembly tool for oil pump shaft
- 998 6485 or 999 2520** Overhaul stand

¹⁾ This tool is used with one or more of Volvo Penta's older products

Design and function

Location of information decals and type plates

There are type plates on the engine and transmission, marked with identification numbers. This information must always be used as a reference when spare parts are ordered. The appearance and location of the type plates is shown below. The figures in brackets refer to the location of the identification number on the type plate.

Engine

Product designation (1)

Serial number (2)

Product number (3)

Certification number (4)

S-drive/Reverser

Product designation (5)

Serial number (6)

Product number (7)

Gear ratio (8)

Propeller designation



Engine and transmission decal



S-drive and reversing gear sign

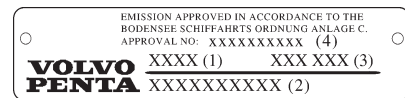
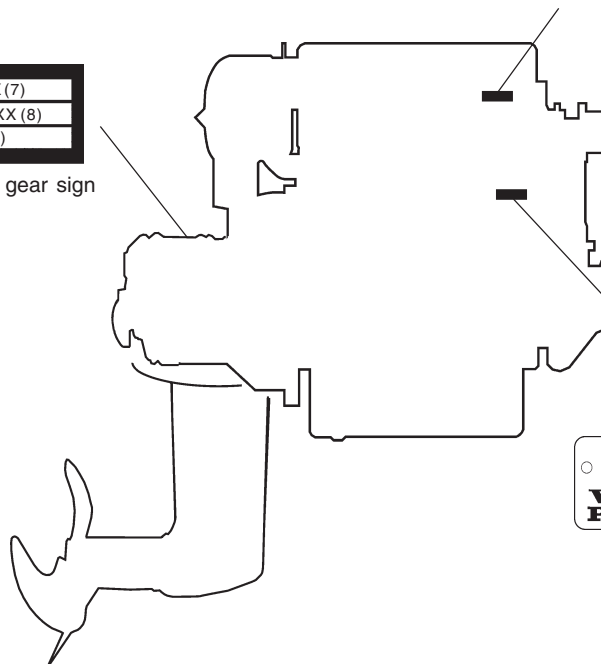

Engine plate

Engine introduction

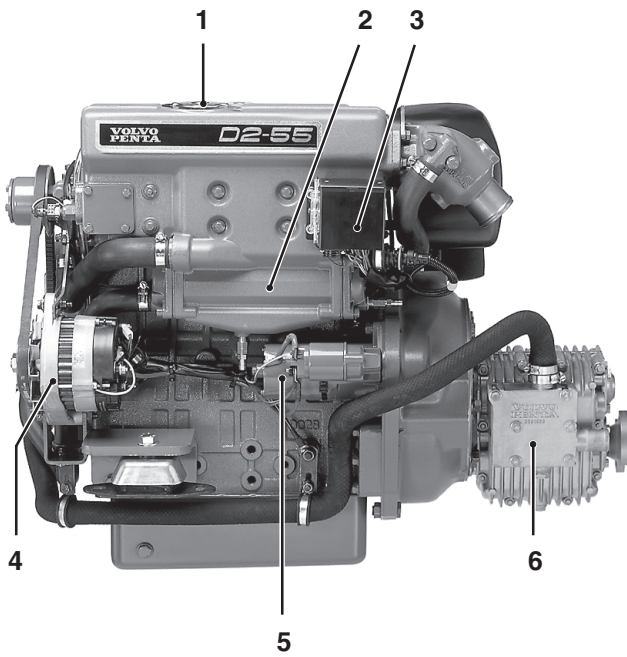

D2-55 A/B with reverser MS25L

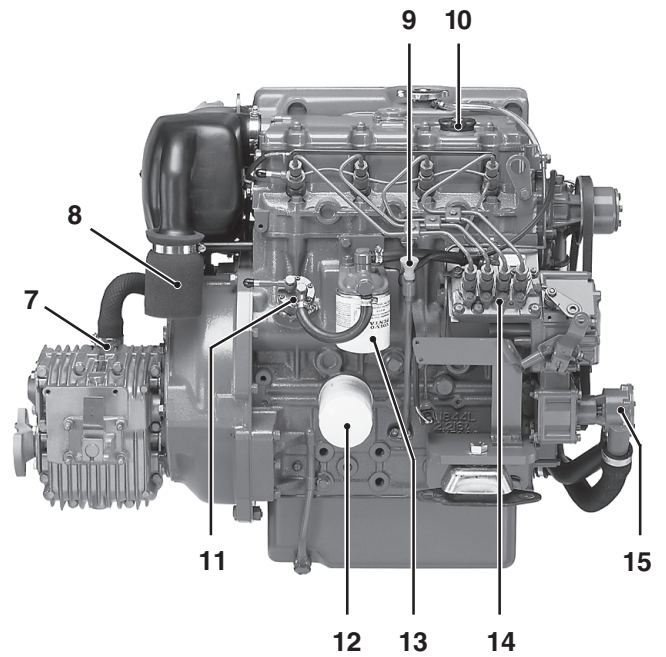

D2-55 A/B with reverser MS25L

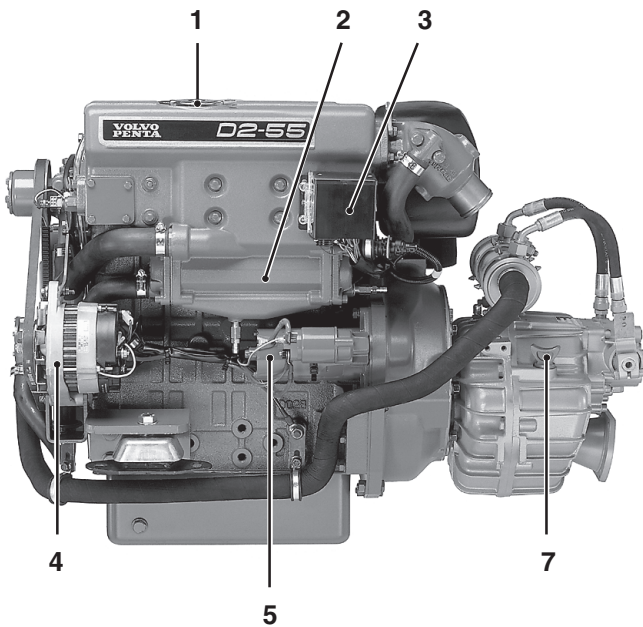

D2-55 A/B with reverser HS25A

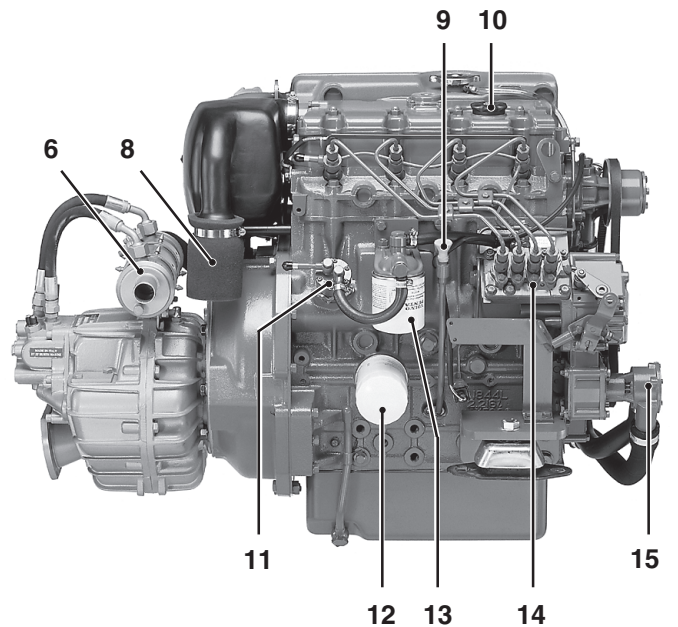

D2-55 A/B with reverser HS25A

1. Coolant filling
2. Heat exchanger
3. Relay box with fuses
4. Alternator
5. Starter motor

6. Oil cooler, reversing gear
7. Oil dipstick, reverser/S-drive
8. Air filter/Air intake
9. Oil dipstick, engine
10. Oil filler, engine

11. Fuel pump
12. Oil filter
13. Fuel filter
14. Injection pump
15. Sea water pump

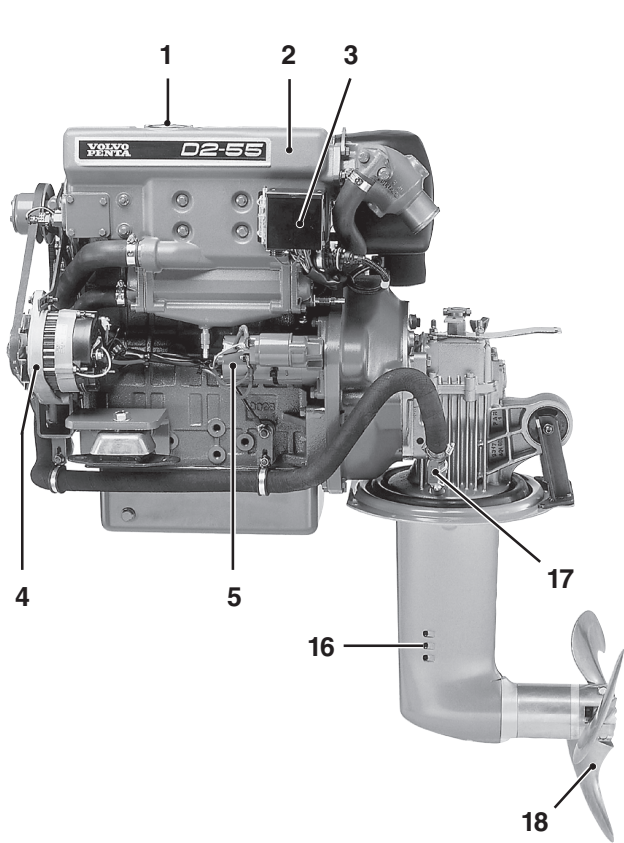

D2-55 A/B with sail-drive MS25S

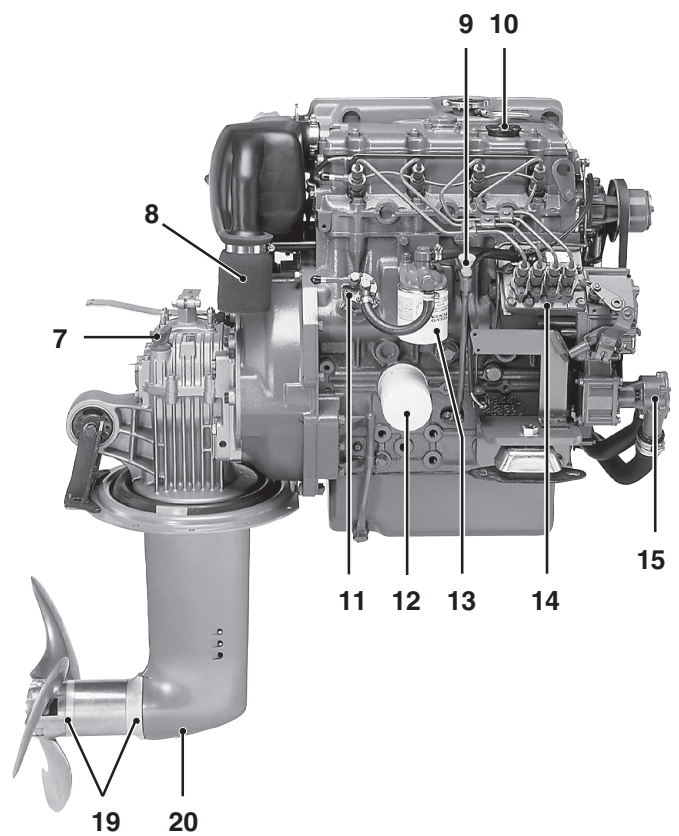

D2-55 A/B with sail-drive MS25S

- 1. Coolant filling
- 2. Heat exchanger
- 3. Relay box with fuses
- 4. Alternator
- 5. Starter motor
- 7. Oil dipstick, reverser/S-drive

- 8. Air filter/Air intake
- 9. Oil dipstick, engine
- 10. Oil filler, engine
- 11. Fuel pump
- 12. Oil filter
- 13. Fuel filter
- 14. Injection pump

- 15. Sea water pump
- 16. Cooling water inlet, S-drive
- 17. Sea cock, S-drive
- 18. Folding propeller
- 19. Sacrificial anodes
- 20. Oil drain, S-drive

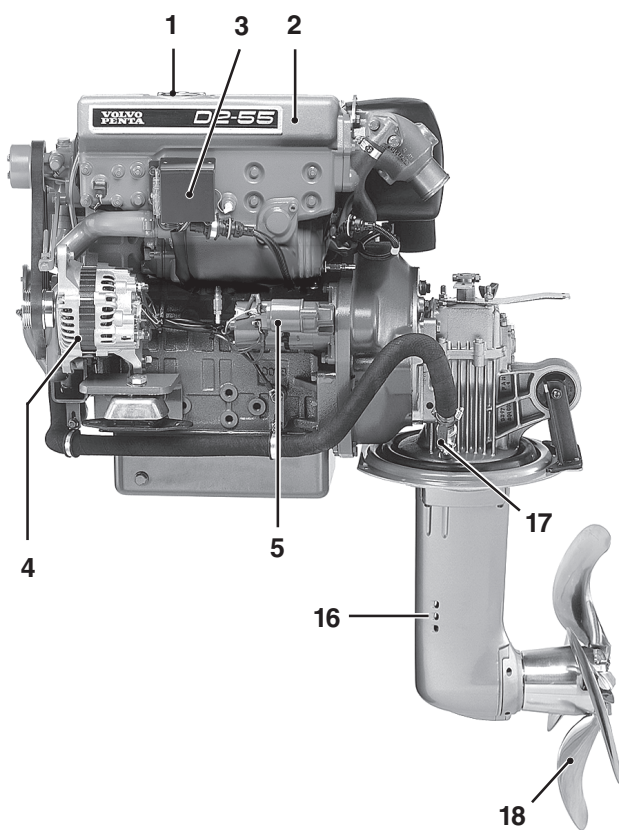

D2-55 C with sail-drive 130S

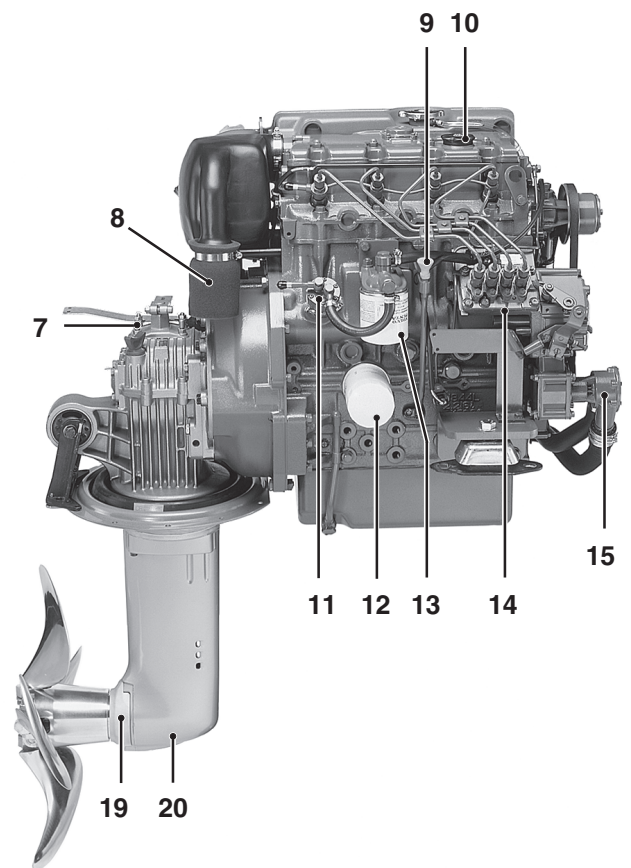

D2-55 C with sail-drive 130S

- 1. Coolant filling
- 2. Heat exchanger
- 3. Relay box with fuses
- 4. Alternator
- 5. Starter motor
- 7. Oil dipstick, reverser/S-drive

- 8. Air filter/Air intake
- 9. Oil dipstick, engine
- 10. Oil filler, engine
- 11. Fuel pump
- 12. Oil filter
- 13. Fuel filter
- 14. Injection pump

- 15. Sea water pump
- 16. Cooling water inlet, S-drive
- 17. Sea cock, S-drive
- 18. Folding propeller
- 19. Sacrificial anodes
- 20. Oil drain, S-drive

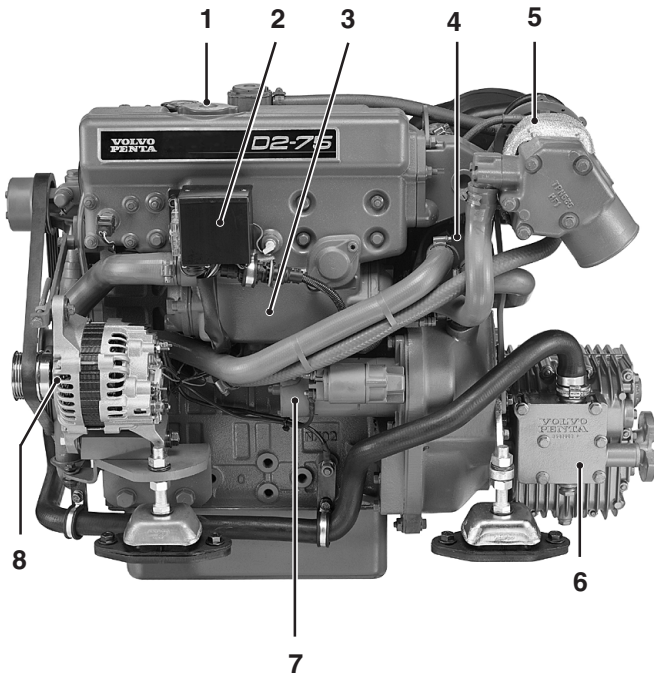

D2-75 A with reverser MS25L

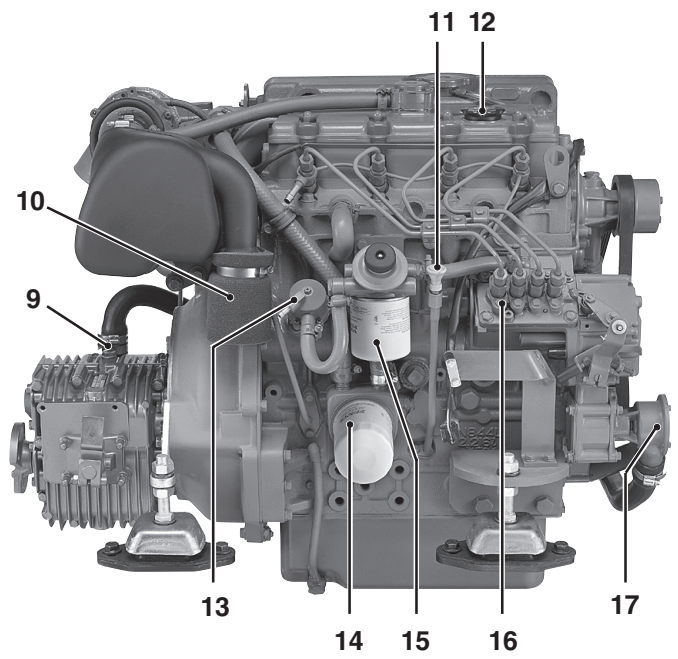

D2-75 A with reverser MS25L

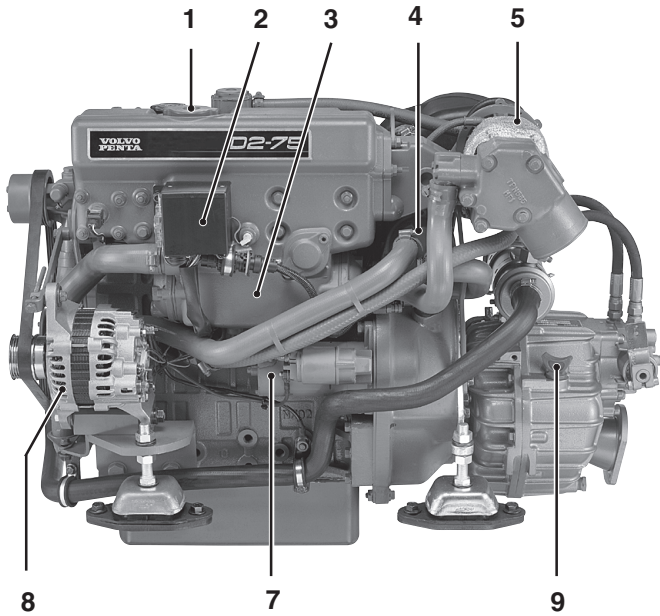

D2-75 A with reverser HS25A

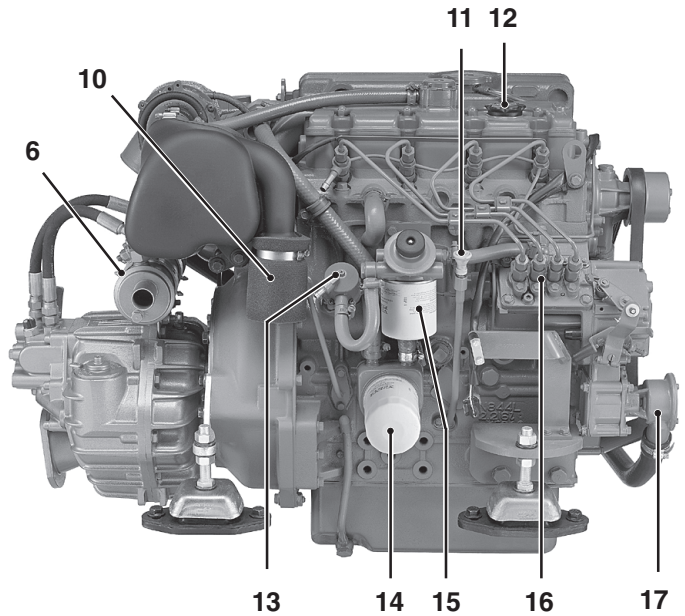

D2-75 A with reverser HS25A

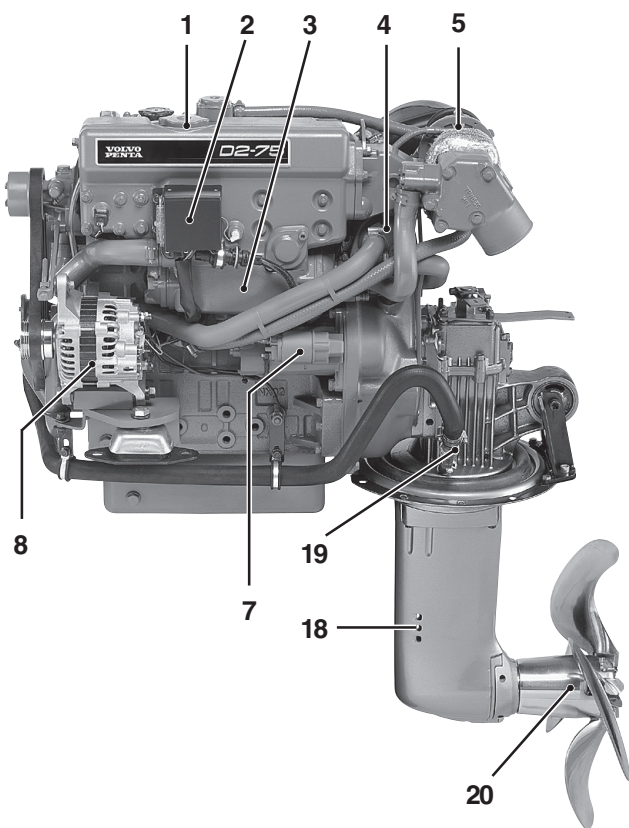

D2-75 A with sail-drive 150S

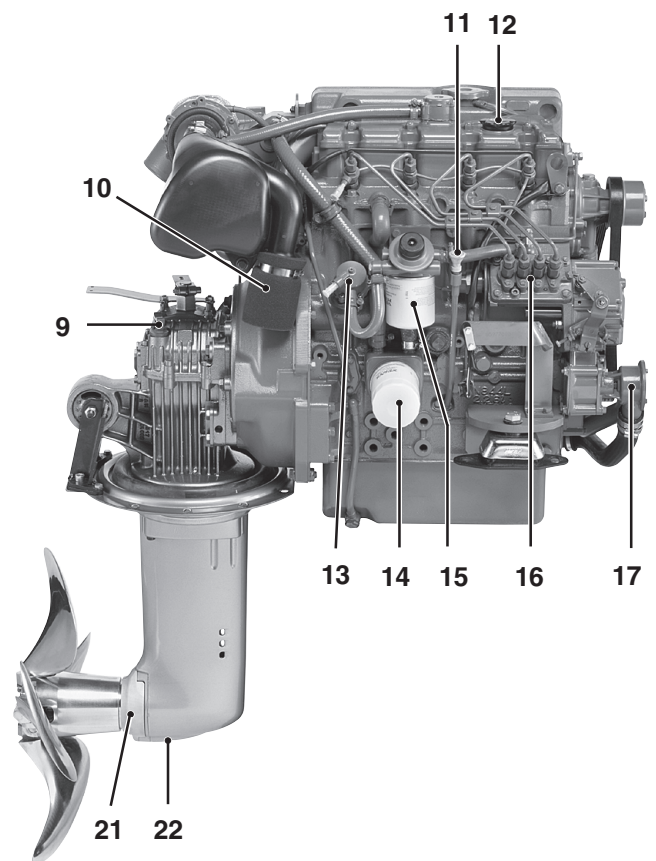

D2-75 A with sail-drive 150S

- 1. Coolant filling
- 2. Relay box with fuses
- 3. Heat exchanger
- 4. Charge air cooler
- 5. Turbo
- 6. Oil cooler, reversing gear
- 7. Starter motor
- 8. Alternator

- 9. Oil dipstick, reverser/S-drive
- 10. Air filter/Air intake
- 11. Oil dipstick, engine
- 12. Oil filler, engine
- 13. Fuel pump
- 14. Oil filter
- 15. Fuel filter
- 16. Injection pump

- 17. Sea water pump
- 18. Cooling water inlet, S-drive
- 19. Sea cock, S-drive
- 20. Folding propeller
- 21. Sacrificial anodes
- 22. Oil drain, S-drive

Component description

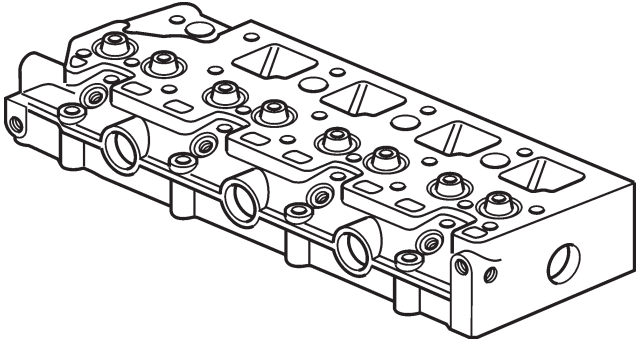

Cylinder head

The cylinder head is made from specially alloyed cast iron. It has replaceable valve seats for inlet and exhaust valves on D2-55 A/B/C and for exhaust valves on D2-75 A.

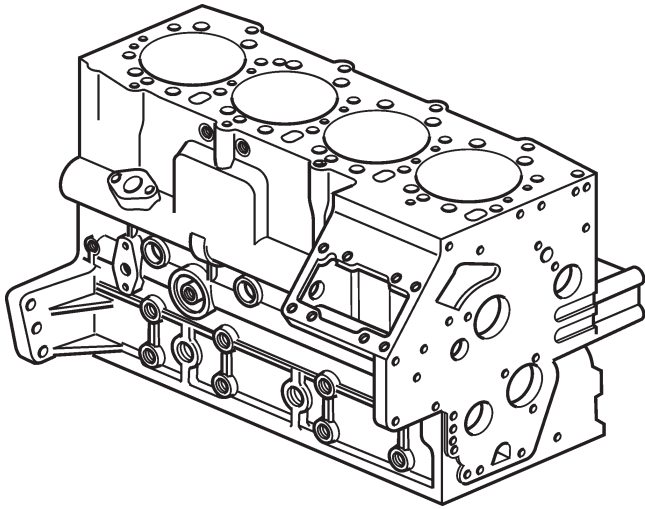

Engine block

The cylinder block is cast in one piece from specially alloyed cast iron.

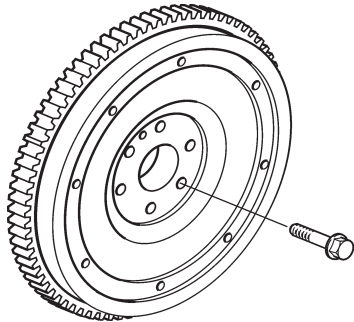

Flywheel

An elastic coupling with a rubber damping element is screwed onto the flywheel. The coupling transfers the power to the reverser/S-drive.

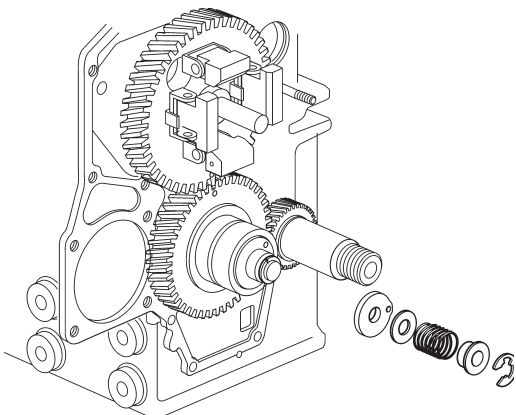

Timing gear

The timing gears comprise both straight-cut and helical gears.

The camshaft and sea water pump are driven from the crankshaft gear via an idler gear. The engine's lubrication pump is integral with the idler gear, and is driven by it. Regulator weights are suspended on the front of the camshaft gear.

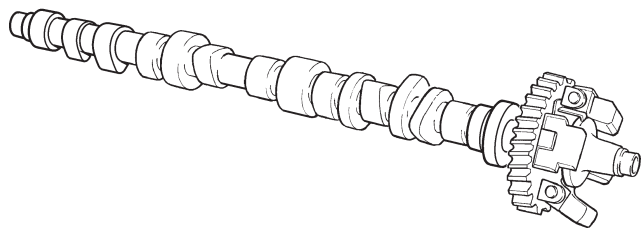

Camshaft

The camshaft is of conventional design with eight lobes that operate the pushrods and valves.

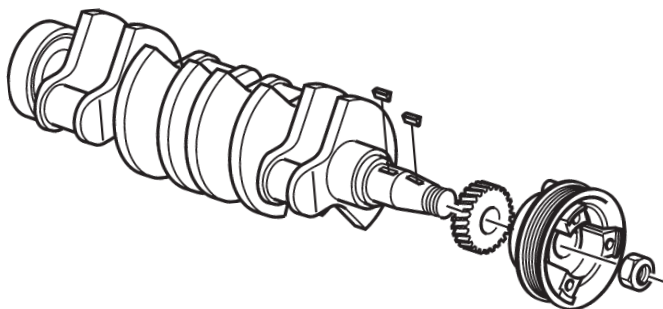

Crankshaft

The crankshaft is suspended in five main bearings. Axial thrust is taken up by separate thrust washers placed on the rear main bearing. The crankshaft is statically and dynamically balanced, and has induction hardened bearing surfaces. The front end of the crankshaft has a Woodruff key and the rear end has a flange upon which the flywheel is mounted.

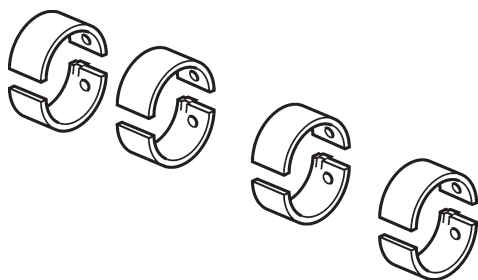

Main and big-end bearings

The main and big-end bearings comprise steelshells lined with bearing metal. The bearings are precision made and are ready to be installed.

The thrust washers for the crankshaft axial bearings are not available in oversize.

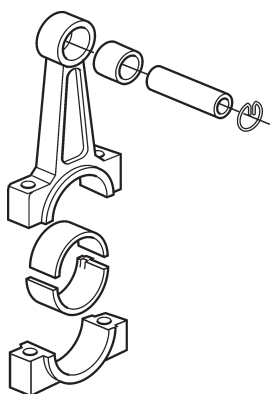

Con rods

The con rods are of I-section. The small end is drilled for gudgeon pin lubrication.

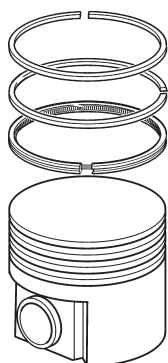

Pistons, piston rings

The pistons are made from aluminum alloy. They are fitted with three piston rings (chrome plated) – two compression rings and an oil ring.

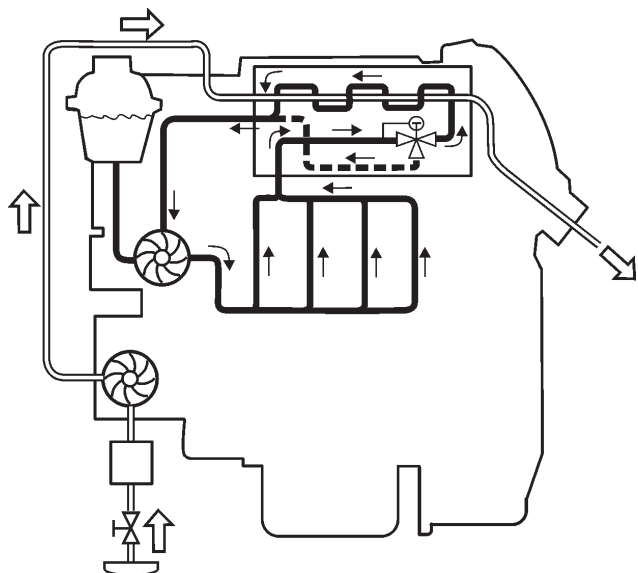

Cooling system, general

The engine is fresh water cooled with a closed cooling system. The system is divided into two circuits.

In the inner circuit, the fresh watersystem, coolant is pumped around by a circulation pump, driven via a belt from the crankshaft pulley.

The fresh water system works under pressure, thus reducing the risk of boiling if the temperature becomes high. If the pressure becomes excessive, a pressure valve opens in the filler cap.

The coolant temperature is regulated by a thermostat.

The flow in the sea water system is accomplished by a gear-driven impeller pump.

The heat exchanger transfers heat from the coolant to the sea water.

As extra equipment, the engine can be equipped with a separate expansion tank.

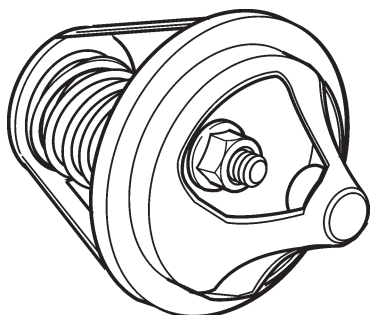

Thermostat

The engine is equipped with a thermostat whose sensor body contains wax.

When the engine is cold, the thermostat closes the way to the heat exchanger. Coolant then passes through a by-pass pipe, back directly to the suction side of the pump. As the engine warms up, the volume of the wax increases and the thermostat progressively opens the passage to the heat exchanger, at the same time as the by-pass channel is closed.

Please refer to the “Technical Data” chapter for opening temperatures.

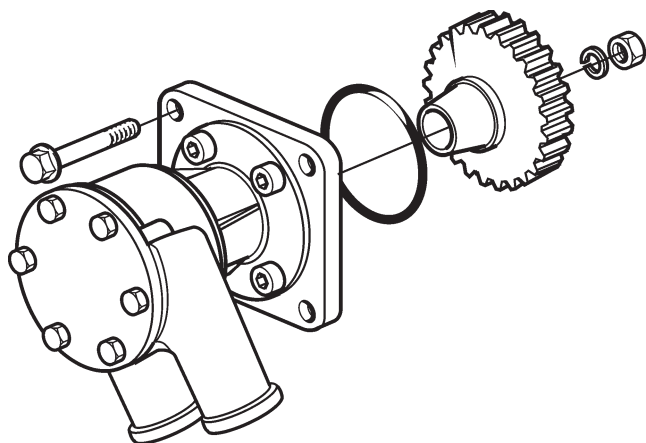

Sea water pump

The sea water pump is driven by the gears in the timing gear. The impeller (pump wheel) is made from rubber and is replaceable.

NOTE! The impeller will be damaged if the pump is run dry.

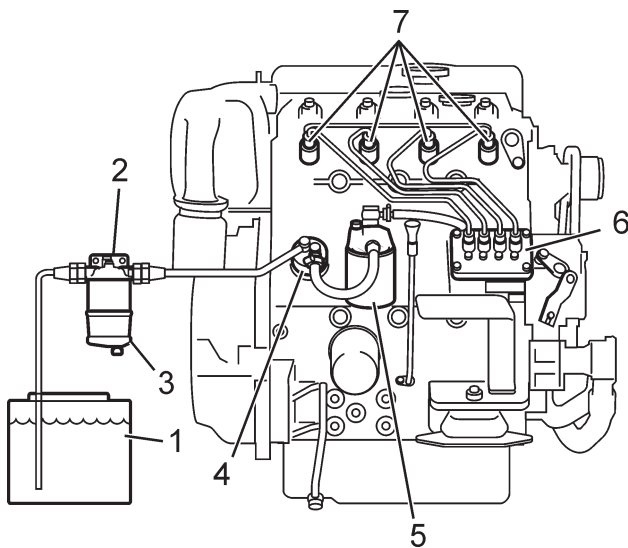

- | | |
|--------------------|---------------------|
| 1. Fuel tank | 5. Fuel fine filter |
| 2. Primary filter | 6. Injection pump |
| 3. Water separator | 7. Injectors |
| 4. Feed pump | |

Fuel system, general

The fuel is sucked from the fuel tank by the feed pump, through a water separator/pre-filter (extra equip.) and is pressed through a fine filter to the injection pump.

Return fuel from the injectors is fed through return fuel lines, back to the tank.

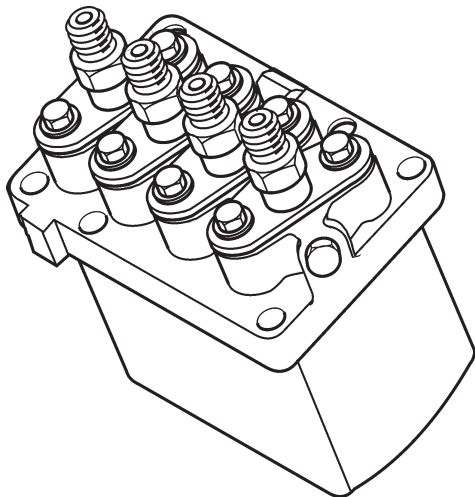

Injection pump

The injection pump is an in-line flange mounted pump. The pump is driven by cams on the engine's camshaft, which operates the pump chambers directly.

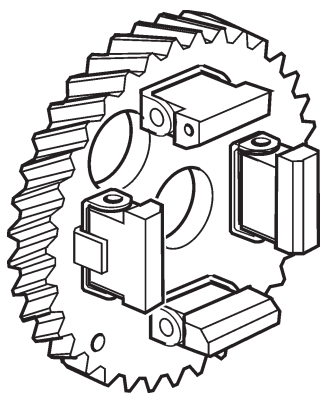

Centrifugal regulator

The regulator is mechanical and works with speed-sensitive regulator weights. It is mounted on the front of the camshaft gear, from where it is also driven.

The regulator weights operate the injector pump control rod via the regulation sleeve, a lever and a regulator arm. The engine speed is regulated throughout the entire range, from low idle to high idle (all-speed type).

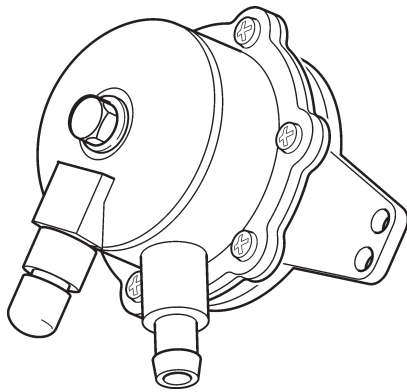

Feed pump

The feed pump is driven by an eccentric on the camshaft rear end. The pump on D2-55 A/B is also equipped with a manual hand pump.

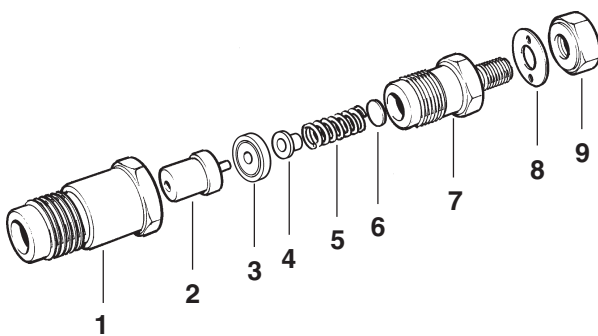

- | | |
|----------------------|---------------------|
| 1. Injector nut | 6. Adjustment shims |
| 2. Injectors | 7. Injector holder |
| 3. Joining piece | 8. Washer |
| 4. Compression screw | 9. Nut |
| 5. Spring | |

Injectors

The engines is provided with pintle - type injectors. Each injector basically consists of a nozzle retainer and a nozzle.

When the fuel pressure increases to the set value (opening pressure), the injector needle which is held pressed against its seat by the compression spring is lifted and atomized fuel is injected into the precombustion chamber of the engine.

The opening pressure of the injector is determined by the compression spring which is adjustable with shims.

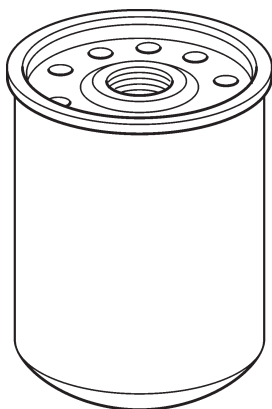

Fuel filter

The fuel filter is discardable. The filter insert is a paper filter.

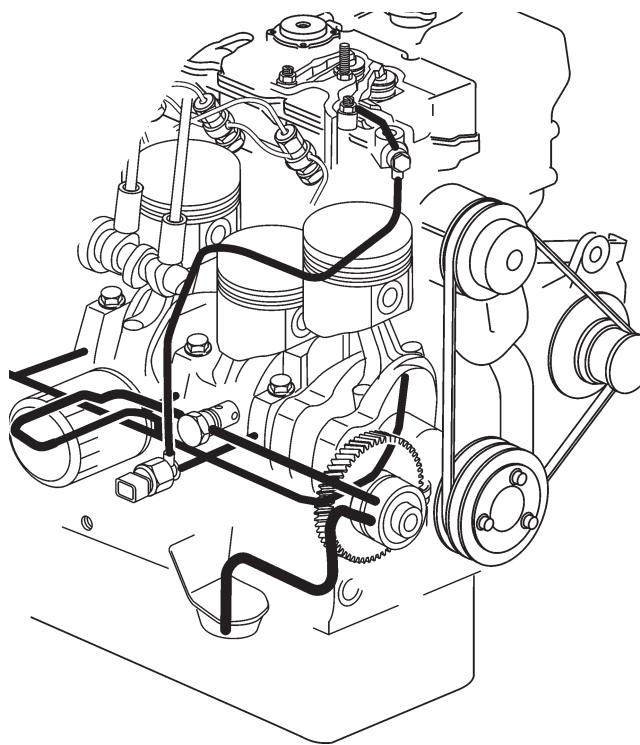

Lubrication system, general

The engine has a pressurized lubrication system with full-flow oil filter.

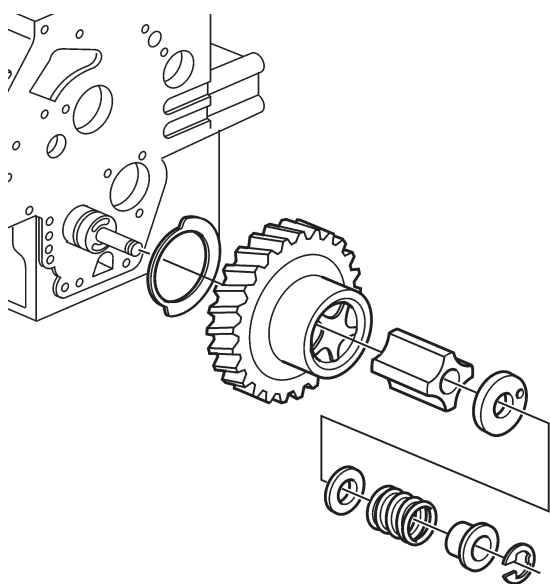

Oil pump

The lubrication pump is located within the idler gear on the timing gears, from where it is also driven.

The pump is a rotor pump, with an inner rotor and an outer rotor, eccentrically mounted in relation to each other. The inner rotor has one "tooth" less than the outer rotor.

The function of the pump is that the volume of the spaces between the inner and outer gears increases and decreases. During the first section of the rotation of the inner rotor, the volume increases, a partial vacuum occurs and oil is sucked into the inlet. After about a half rotation, the volume is reduced and a pressure occurs, which forces the oil out through the outlet.

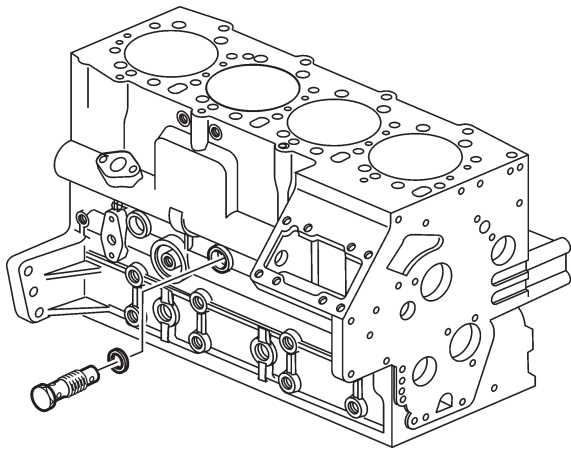

Reduction valve

The lubricating oil pressure is limited by a reduction valve. The valve is located in the lubricating system just before the oil filter. The valve opens with high pressure and allows the oil to flow back into the sump.

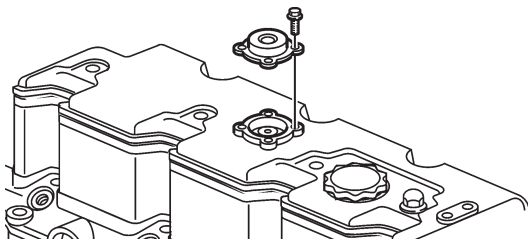

D2-55A/B/C

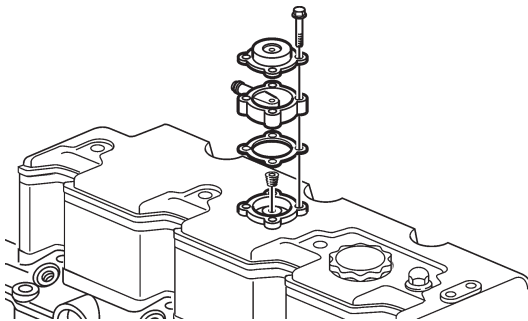

D2-75A

Crankcase breather

To prevent over-pressure and to separate fuel vapor, water vapor and other gaseous combustion products, the engine is fitted with closed crankcase ventilation.

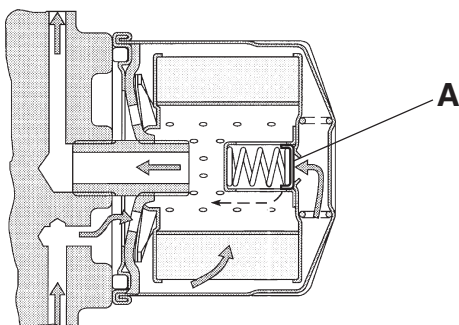

Oil filter

The filter is a full flow filter, which means that all the oil is filtered before it is forced out into the lubrication system.

The filter element consists of folded filter paper.

There is a bypass valve (A) at the base of the filter, which opens and allows oil to flow past the filter if the filter insert should become blocked.

Repair instructions

General

A condition test should be done before each major service activity, if possible, to determine the general condition of the engine and discover any concurrent fault causes. A condition test requires the engine to be run, so this should be done before the engine or any engine components are disassembled.

Please refer to “Condition test, engine”.

Measures before overhaul in boat

- 1 Remove battery power.
- 2 Clean the outside of the engine.
NOTE! Make sure that wash residue is collected for destruction and does not inadvertently end up in the water. Also refer to the warning text under “Actions after lifting the engine”.
- 3 Work involving the cooling system: Close the sea cocks and drain the coolant from the sea water and fresh water systems.

 **WARNING!** Make sure that all sea water inlets are securely closed, so that water cannot find its way in during disassembly of cooling system sub-components.

Actions before lifting the engine from the boat

- 1 Lift the boat ashore.
- 2 Disconnect battery power, remove battery connection on the starter motor.
- 3 Disconnect the engine-instrument cable harness connector.
- 4 Disconnect the sea water connection/keel-cooling connection.
- 5 Remove the exhaust system.
- 6 Close the fuel stopcocks. Remove the fuel connections.
- 7 Disconnect the throttle and gearshift wires.
- 8 Disconnect the propshaft from the reverser. Undo the engine mounting pads from the bed and lift the engine out.

Actions after lifting the engine

- 1 Clean the engine.
 **IMPORTANT!** Remember the following when washing with a power washer: Be extremely careful when cleaning, to avoid getting water inside engine components. When a power washer is used, the water jet must never be aimed at seals, such as shaft seals, joints with gaskets, rubber hoses or electrical components.
- 2 Drain the engine oil.
- 3 Remove the reverser (if required).

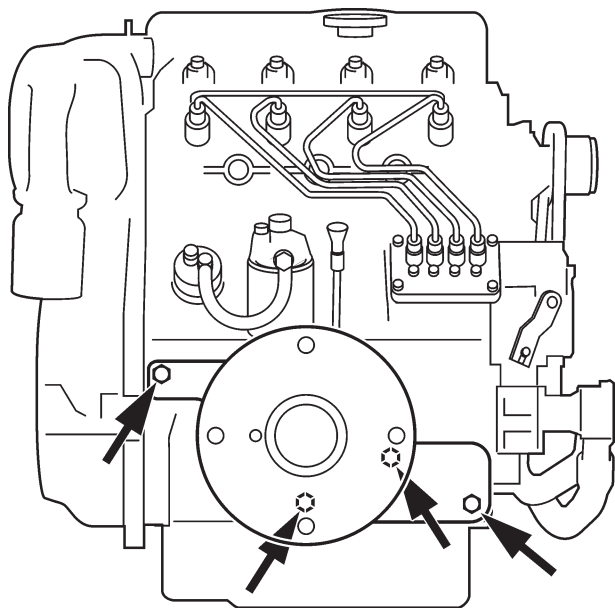

Engine fixture, fixing

Special tools: 885 485, 998 6485 or 856 927

Use fixture 885 485 to attach the engine to overhaul stand 998 6485 or 856 927.

The fixture is attached to the right side of the engine as illustrated below.

NOTE! It is important that the instructions regarding number of attachment bolts and sizes are followed to ensure secure engine attachment.

Bolts required:

1 pcs M10 x 35 mm

3 pcs M14 x 1.5 x 35 mm

Before the engine fixture can be mounted and the engine attached to the overhaul stand, the right front engine mounting, oil dipstick tube, oil cooler with oil filter and turbo oil pipe (D2-75), must be removed from the engine.

Condition test, engine

Compression test

Special tools: 885 484, 885 252 and 998 8539

A compression test is done, which shows the sealing of the cylinders and valves, to assess the condition of the engine in a simple, reliable manner.

- Warm the engine up, then stop it.
- Remove all the injectors and test each of the cylinders in turn.

! **IMPORTANT!** Observe the greatest possible cleanliness, to avoid getting dirt in the fuel system. Plug the connections for the disassembled injectors and fuel pipes.

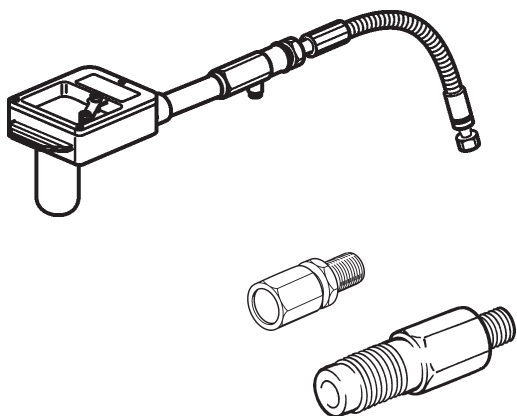

The compression pressure shall be read off at normal starter motor speed, refer to "Technical data".

Low combustion pressure in all cylinders indicates worn cylinder bores and piston rings. If one cylinder has lower compression pressure than the others, the reason can be poor valve sealing, broken piston rings or a damaged cylinder head gasket.

Insert adapter nos. 885 484 and 885 252 in the injector hole. Install a compression gauge 998 8539 in the adapter, and carry out the compression test.

Group 21 Short block

Short block, disassembly

Special tools: 885 510, 885820, 885822

Empty the oil and water from the engine.

Lift the engine with a suitable lifting device. Installing the engine fixture, please refer to "Engine fixture, fixing".

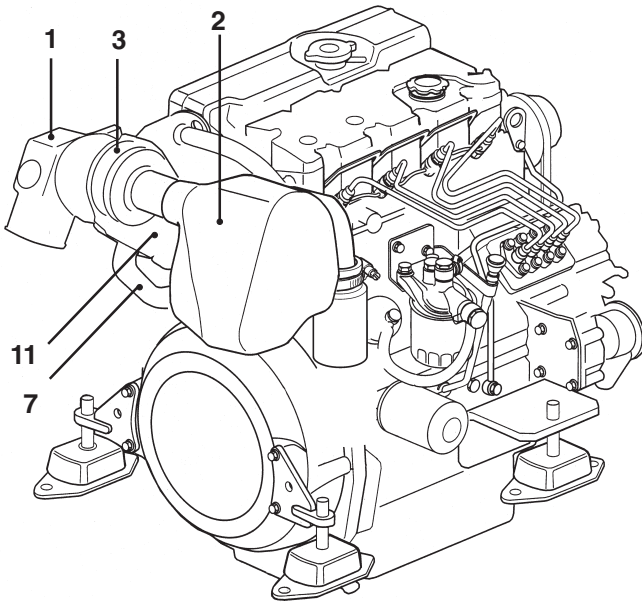

1. Remove the exhaust bend (1).
2. Remove the induction silencer (2).
3. Remove the turbo (3) with associated oil return pipe (only D2-75).
4. Remove the electronics box (4) complete with cabling.
5. Remove the starter motor (5) and alternator (6) and front left engine mounting.
6. Remove the coolant hoses (7), heat exchanger (8), sea water pump (9) and circulation pump (10).
7. Remove the charge air cooler (11) and oil pipe to the turbo (only D2-75).

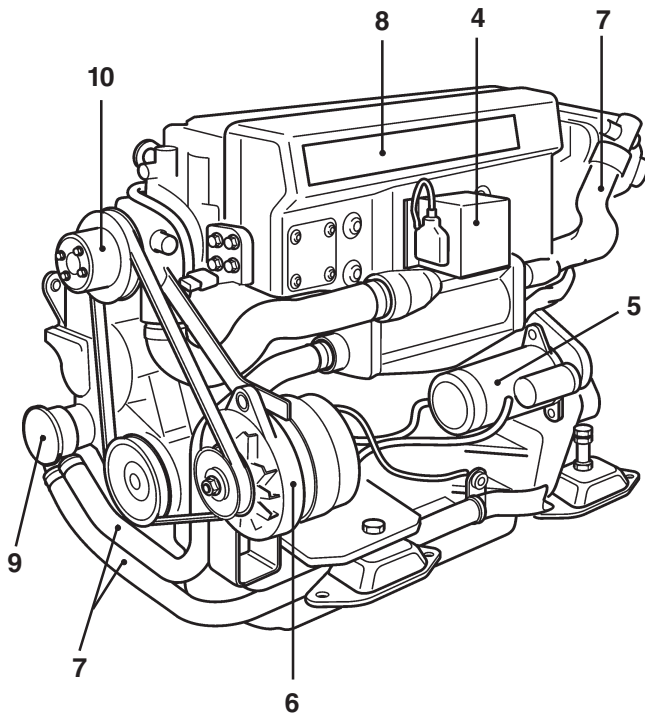

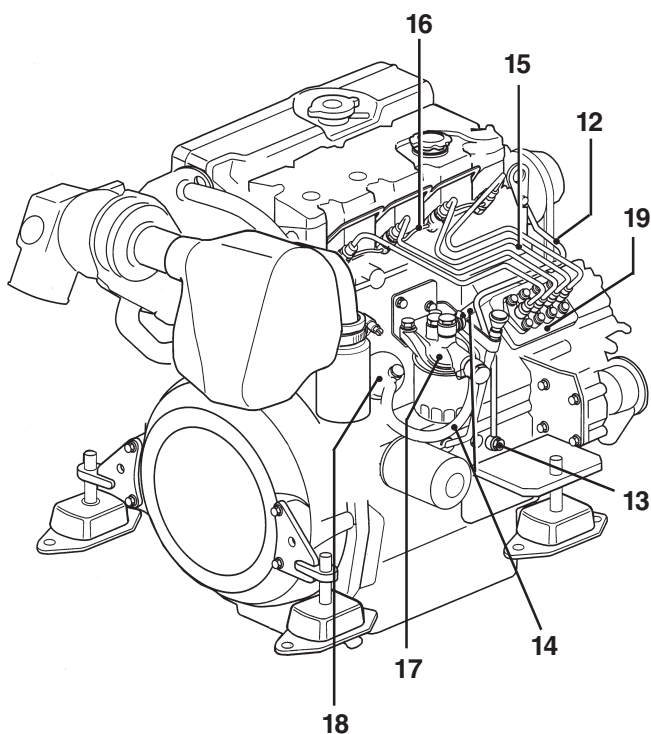

8. Remove (13) oil pressure monitor and oil pressure pipe (12) to the cylinder head.
9. Remove the fuel lines (14) between the injection pump, fuel filter and feed pump.

⚠ WARNING! Observe the greatest possible cleanliness in work on the fuel system. Watch out for fuel spillage, diesel oil is hazardous on repeated skin contact.

10. Remove the supply pipes (15) between the fuel pump and injectors, use the nut on the return fuel line as a counterhold so as not to bend the pipes. Remove the fuel supply pipes and put them on a clean, dry surface.

11. Remove the return fuel pipe (16) and the injectors.

⚠ IMPORTANT! Observe the greatest possible cleanliness, to avoid getting dirt in the fuel system. Plug the fuel pump and injector connections with suitable plugs, for example kit number 885510.

12. Remove the fuel filter and bracket (17), feed pump (18) and the nipple to the injection pump.

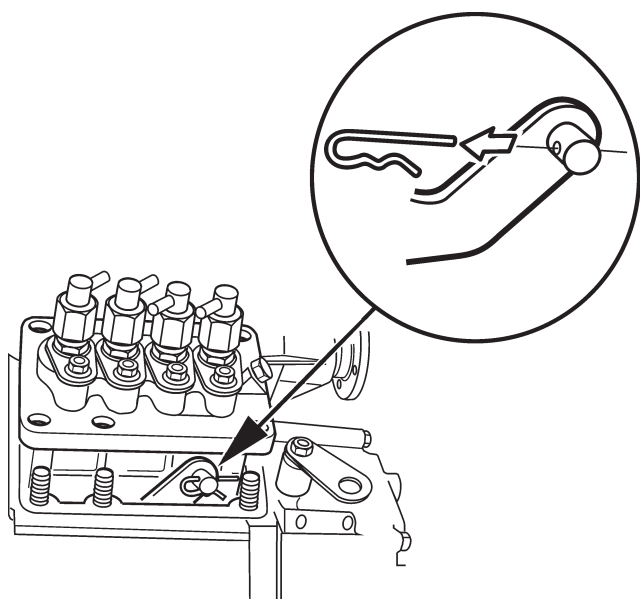

13. Remove the injection pump (19). Remove the fixing screws and nuts on the pump. Turn the stop lever clockwise and carefully lift the pump, to make the lock clip on the regulator arm accessible.

Remove the lock clip and free the regulator arm.

⚠ IMPORTANT! Be careful when disassembling the injection pump, avoid damaging or bending the lever.

NOTE! Retain any shims from beneath the injection pump flange. Use the same thickness of shims when re-installing, unless the camshaft, engine block or injection pump have been changed.

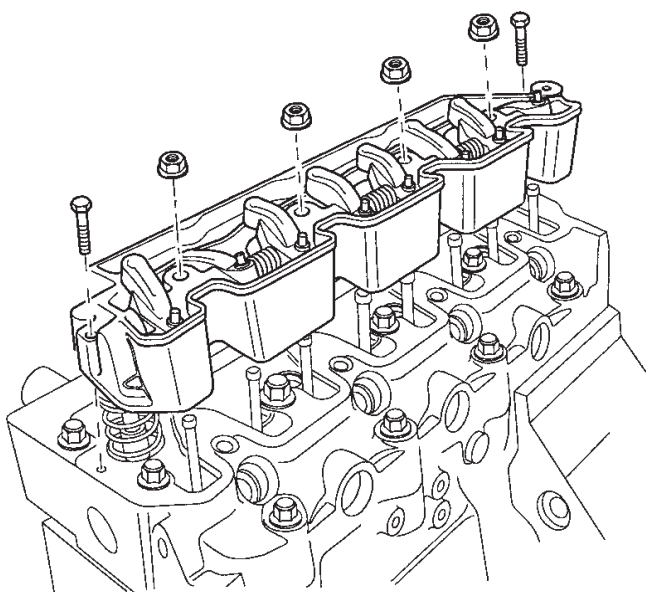

14. Remove the rocker cover, power rail and glow plugs.
15. Remove the lower part of the rocker cover with integrated rocker arm bridge. Start by unscrewing the two M6 screws at the outer edge, then loosen the rocker arm bridge nuts half a turn at a time, until the rocker arms are no longer under load.
16. Prepare a stand, marked with cylinder numbers. If the rocker arms, valve caps, pushrods and valve lifters are to be re-used, these **must** be fitted in their original positions.

Lift the push rods and valve caps out and put in them in number sequence in the marked stand.

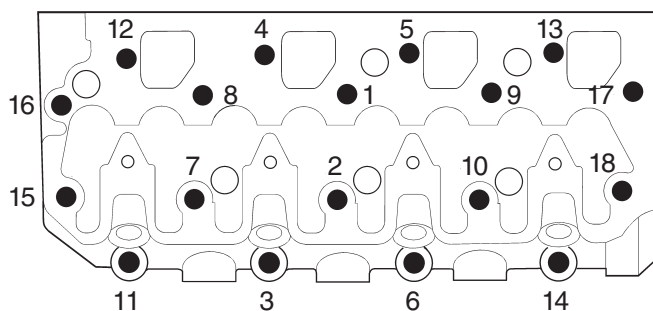

17. Loosen the bolts in the opposite tightening sequence (refer to "Installing cylinder head"). Remove the cylinder head.
18. Remove the valves, if these are to be re-used, they **must** be fitted in their original positions. Special tool magnetic pen, part number 885 822.
19. Remove the crankshaft sensor, flywheel casing and vibration damper.

NOTE! To reduce the risk of damage to the crankshaft sensor, this should be removed before the flywheel casing is removed.

20. Mark the position of the flywheel on the crankshaft. Remove the flywheel.
22. Remove the inner flywheel casing and the rear shaft seal.

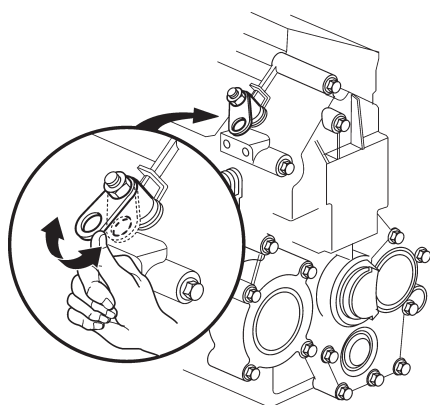

23. Remove the pulley, use special tool 885 820 and 3 pcs. M10x40 mm bolts. Remove the timing gear cover. Load the stop arm so that the springs on the inside of the housing do not come out of position or spring out.

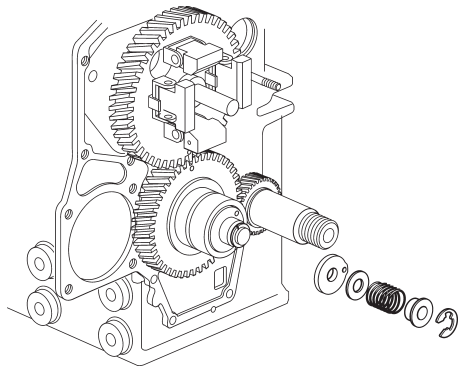

24. Remove the idler lock ring. Save the sleeve washer, spring and shims.

Lift away the idler gear complete with cover and oil pump. Note the thrust washer behind the oil pump.

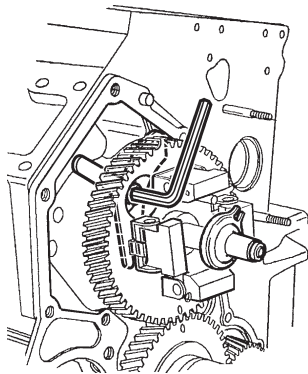

25. Remove the camshaft and gear. Remove the screws from the locking plate, the screws are accessible through a hole in the camshaft gear.

Lift out the camshaft complete with gear and regulator weights.

NOTE! Take care so that bearings, journals and cam lobes are not damaged.

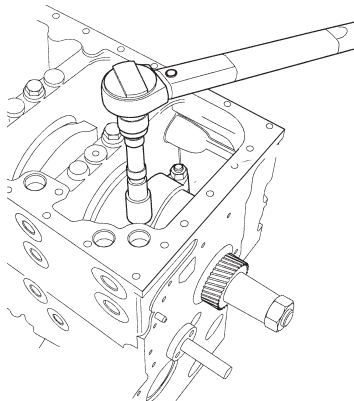

26. Remove the timing gear plate.

27. Invert the engine and remove the sump together with the external oil pipe. Remove the oil strainer and suction pipe.

28. Scrape away the carbon from the top of the cylinders to simplify disassembly. Check that the con rod caps are marked so that they can be reassembled correctly.

Remove the con rod caps and push out the pistons.

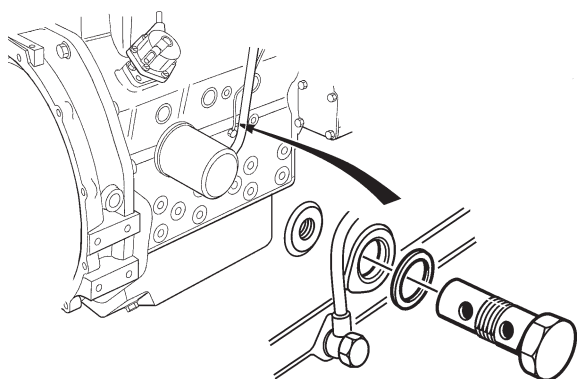

29. Remove the oil pressure valve to allow removal of the crankshaft and simplify flushing of the oil channels.

⚠ IMPORTANT! Check that the oil pressure valve on the right side of the block is removed before removing the crankshaft.

NOTE! Tape the crankshaft gear to protect the bearing surfaces in the block during disassembly.

30. Remove the locking screws holding the main bearing caps. Lift the crankshaft out carefully, complete with caps, backwards.

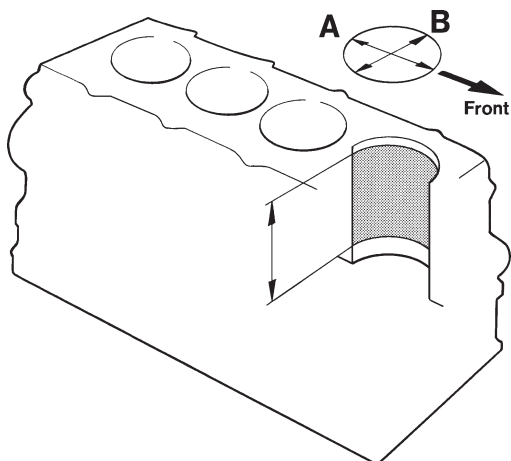
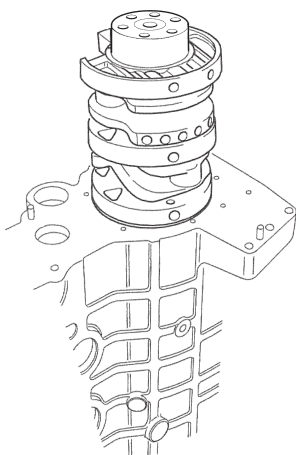
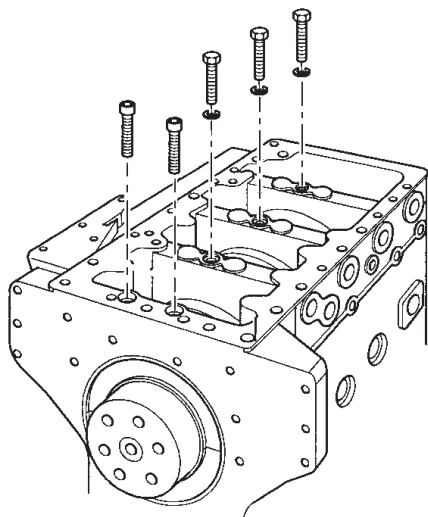

Inspecting the engine block

Upper block plane

Check that the upper engine block plane does not have any cracks or other damage. Also check that it is not warped (in the same way as for the cylinder head).

Max warpage, please refer to "Technical Data".
Change the engine block if it is outside the tolerances.

Cylinder bore

Check that the cylinder bores are not scored or damaged in other ways.

Measure the cylinder bores at the upper and lower turning positions for the piston rings (app 10 mm and 100 mm below the engine block plane) and also in the middle. Measurement should be done with an internal dial gauge and both along and transverse to the engine block (A and B).

Concerning max. permitted cylinder diameter, see under "Wear tolerances" in Technical data.

Cylinder head, overhaul

Disassembling cylinder head

Special tools: 885 023, 885 498

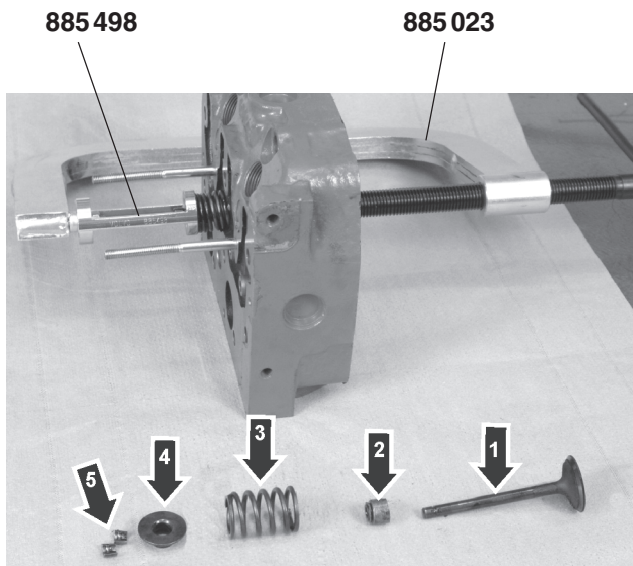

1. Remove the valves (1) and valve springs (3). Compress the springs with compressor 885 023 together with pressure foot 885 498 and remove the valve cotters (5). Place the valves in order in a marked valve holder, so they can be refitted in their original positions. Remove the valve stem seals (2).
2. Clean all components. Be especially careful with the cylinder head oil and coolant channels.
3. Remove any remaining carbon/deposit from the cylinder head sealing surface.

Note. A wire brush may not be used for cleaning the cylinder head bolt threads or the underside of the bolt heads.

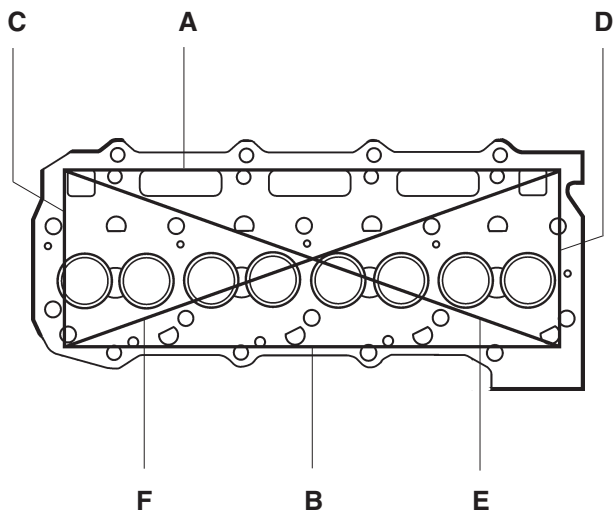

Inspecting the cylinder head

Cylinder head warping must not exceed the value given in "Technical data". The check should be done with a feeler gauge and a straight edge. Measurement is done at six positions (A - F).

If warpage above the permissible level is found, the cylinder head must be changed. If leakage has been found, or if the cylinder head has blow lines, no special measurement is needed since such a cylinder head will have to be attended to in any case.

Check the valve seats and check that the studs are firmly seated.

Inspect the cylinder head for cracks. Carefully check the areas around the valve seats and the holes for the injector nozzles.

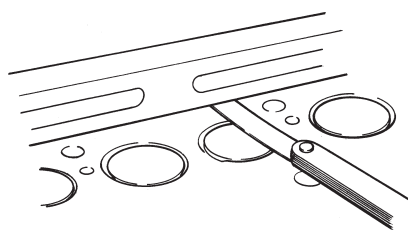

Changing the valve seats

NOTE! On D2-75 only the inlet valve seat can be changed. On D2-55 both the inlet and exhaust valve seats can be changed.

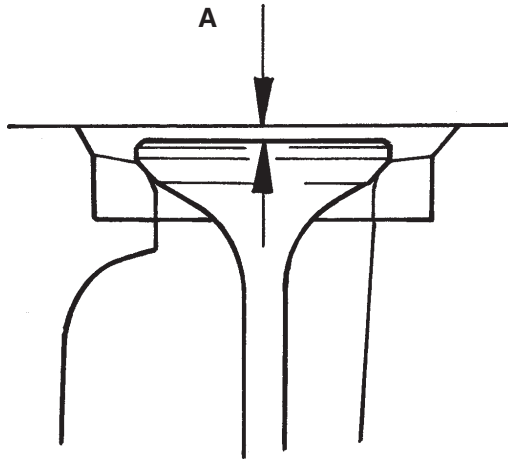

The valve seat should be changed when the distance "A" measured with a **new** valve exceeds 1.8 mm.

1. Remove the old valve seat by heating it with a gas flame (600-700 °C) diagonally across the seat.
Let the cylinder heat cool for 3-5 min in the air. Then carefully tap the seat out with a mandrel (check that the cylinder head is not damaged).
The valve seat can also be milled out (check that the cylinder head is not damaged).
2. Carefully clean the valve seat bed in the cylinder head. Check the cylinder head for cracks.
3. Cool the new seat with dry ice or similar to minus 60-70 °C and heat the cylinder head to approx. 60-100 °C.
4. Press the seats into the cylinder head. Use a hydraulic press and a suitable mandrel.
5. Machine the seats to the correct angle and width.

Grinding of valve and valve seats

Special tools: 885 023, 885 498

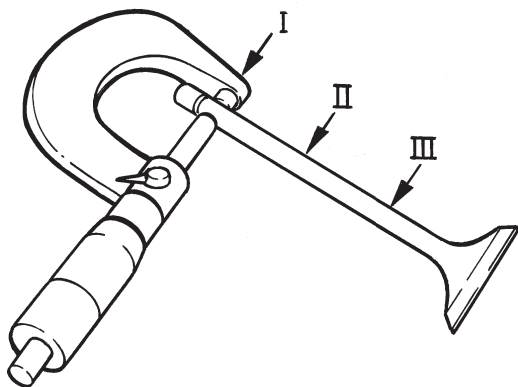

1. Use valve spring compressor 885 023 and pressure foot 885 498 to remove the valve cotters. Remove the valve washers, springs and valves. Place the parts in the correct order in a valve holder. Remove the valve stem seals.
2. Clean the components.
3. Check valve stem wear. Measure the diameter with a micrometer at points I, II and III.

Diameter, min. inlet: 6.89 mm

Diameter, min. exhaust: 6.84 mm

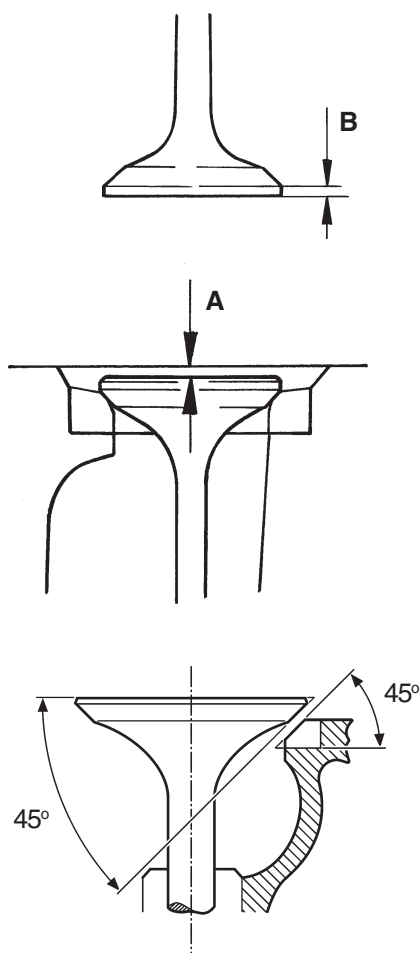

4. Grind the valves in a valve grinding machine.
Grind the sealing surface as little as possible, just enough to “clean” it up. If the edge of the valve head (B) after grinding is less than 0.5 mm, the valve must be scrapped. Equally, any valve with a bent valve stem must be scrapped.
5. Check the wear of the valve guides (refer to “Check of valve guides”) before machining the valve seats.
6. Mill the valve seats. When machined, only remove enough material to give the valve seat the correct shape and a good mating surface.

Note. Do not grind so much that the valve depth exceeds the permissible value. Please refer to “Changing the valve seats”.

New valve seats shall be milled down so far that the distance between the cylinder head plane and the valve head surface (A) is 0.65-0.95 mm

7. Grind the valves in with grinding paste, and check contact with marker dye.
8. Install the seals, valves, valve springs, spring washers, valve cotters and valve caps. Refer to “Assembly of cylinder head”.

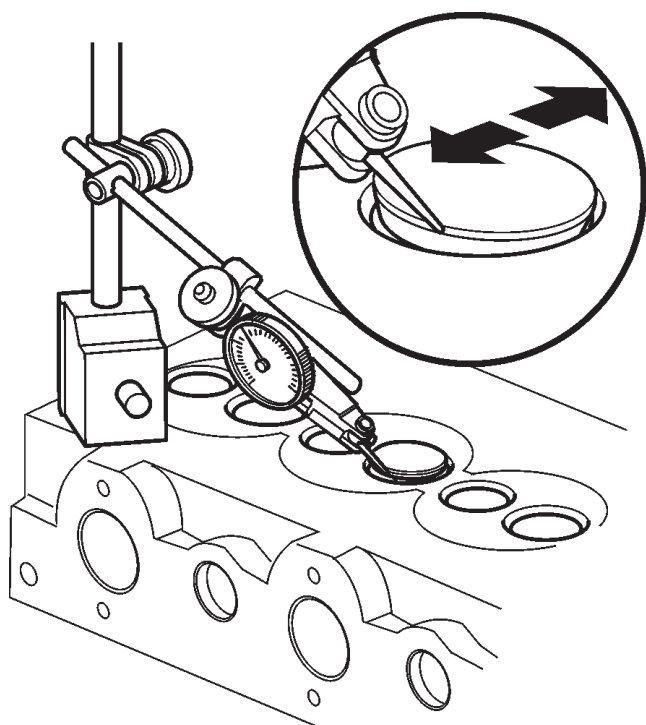

Checking the valve guides*

Special tools: 999 9683, 999 9696

- 1 Put the cylinder head on the bench, and put valves in the valve guides.
- 2 Measure the wear with rocker indicator 999 9683 and magnetic stand 999 9696.

Lift each valve about 2 mm from its seat, put the measurement tip on the edge of the valve head and check the wear.

Permissible clearance between valve and valve guide:

Inlet valve, max clearance 0.20 mm

Exhaust valve, max clearance 0.25mm

* **Note.** Since the valve guides are machined directly in the cylinder head, the cylinder head must be changed when the clearance is too great, even when the valve is new.

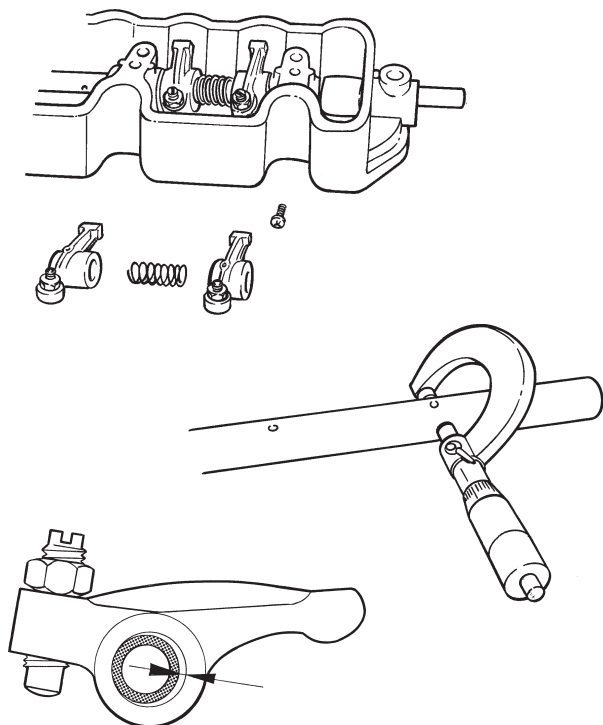

Overhauling the rocker arm mechanism

Special tools: 999 6400

1. Remove the screw from the front edge of the rocker arm shaft.
Screw an M8 bolt into the rocker arm shaft. Grab the bolt with i.e. a pair of pliers and pull the rocker arm shaft out.
2. Disassemble the rocker arm mechanism. Remove the rocker arms, springs and washers.
3. Clean the components. Be especially careful with the rocker arm shaft oil channels and the oil holes in the rocker arms.
4. Check the wear of the rocker arm shaft with a micrometer.
5. Check that the rocker arm bearing surface is not worn oval. Check the clearance between rocker arm and shaft.
Check that the spherical section of the adjustment screw is not deformed or worn. The threads on the pin and lock nut should be undamaged. The lock nut should be in good condition.
6. Oil the rocker arm shaft and assemble the various parts.

Assembly of cylinder head

Special tools: 885 023, 885 498

1. Press the new valve stem seals onto the valve guides.

Note. The seals for the inlet and exhaust valve guides are different. The inlet valve seal has a silver spring while the exhaust valve seal's spring is black.

2. The valves must be installed in the correct order. Oil the valve stems and install one valve (1) in its guide. Place the valve spring (2) and spring washer (3) in place and compress the spring with valve spring compressor 885 023 and pressure foot 885 498. Install the valve cotters (4).

Be careful when mounting the valves and when compressing the springs, so that the valve stem seals are not damaged. Check that the valve cotters are properly seated.

3. Install the valve caps (5) once all the valves are fitted.
4. Mount new core plugs if these have been removed.
5. Install the glow plugs. Tightening torque, please refer to "Technical Data". Install the power rail.

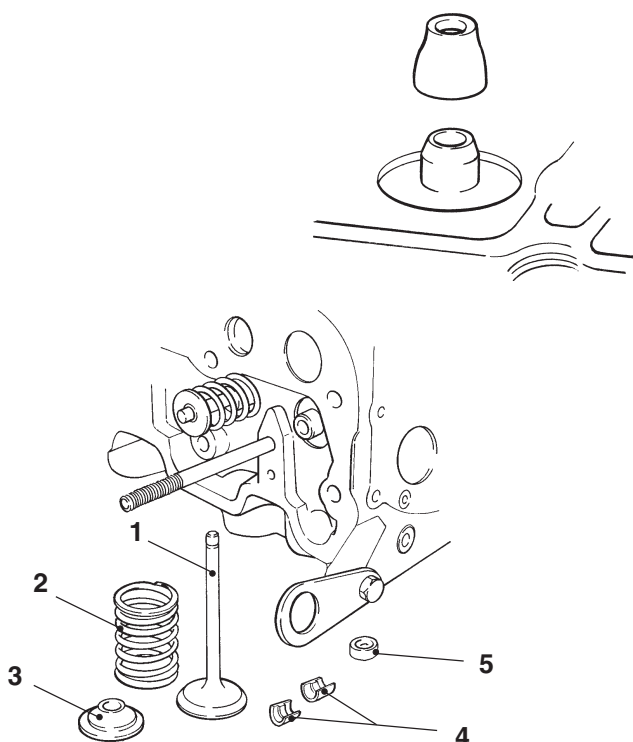

Inspecting the crankshaft

Clean the crankshaft carefully in all channels after disassembly and inspect thoroughly to determine if overhaul is really necessary.

1. Check wear and ovality with a micrometer. Measure the diameters "A-A" and "B-B" at points "1" and "2".

Max. permissible taper and ovality in the main and big-end journals is 0.05 mm*. Grind the crankshaft to a suitable undersize dimension, if these values are exceeded. Bearing shells are available in two oversizes.

NOTE! Check first which oversize bearing shells are available for the engine type in question.

2. Measure lengthwise crookedness in the crankshaft (runout). Lay the crankshaft on a pair of V-blocks placed under the front and rear main bearing journals. Alternately, the crankshaft can be set up between centers. Measurements shall be done on the center main bearing journal(s).

Max. lengthwise crookedness (runout) refer to "Wear tolerances".

If these values are exceeded, the crankshaft must be straightened or replaced.

3. Check that the crankshaft seal mating surfaces on the crankshaft are not worn or damaged.

* Max. wear, refer to "**Technical data**".

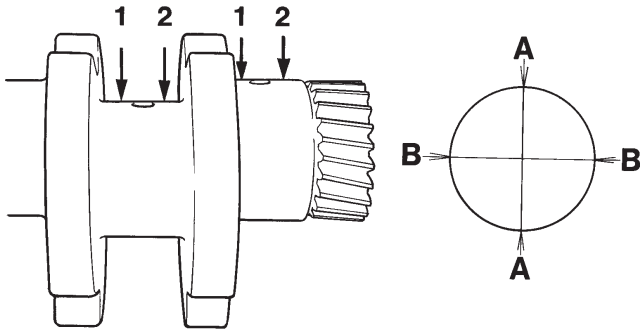

Inspection of main and big end bearings

Check the main and big-end bearing shells and the front crankshaft bush. Change worn bearing shells, or any with damaged bearing surfaces.

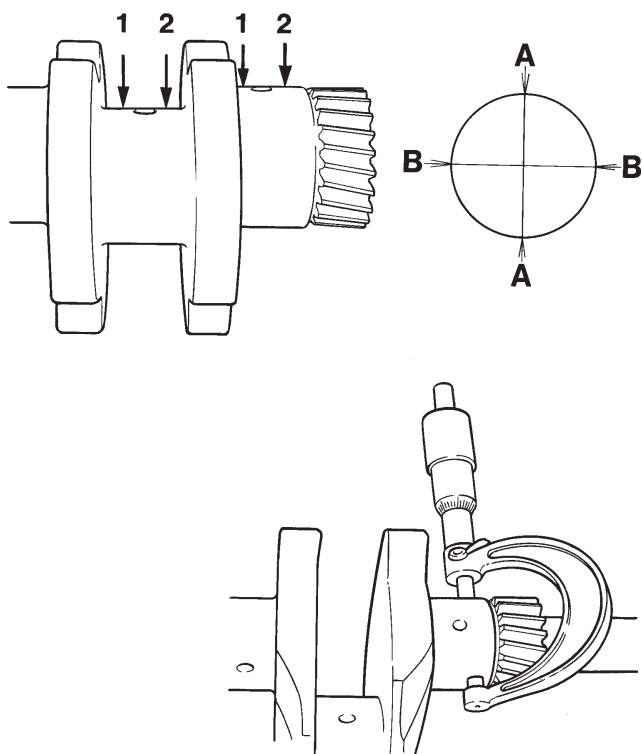

Inspection of front crankshaft bush

Check the bearing play between the crankshaft journal and the bush. Use both internal and external micrometers.

1. Measure the bushes inner diameter at points 1 and 2. Measure in two directions ("A" and "B") at each point.
2. Measure the bearing journal outer diameter and calculate the bearing play (difference between previous measurement and max. diameter of the bearing journal).

Max bearing clearance, please refer to "Technical Data".

Change the bush if the clearance exceeds the permissible value. If necessary, the crankshaft can be ground to a suitable undersize and the bush replaced with a corresponding oversize.

Check the bearing play again before the crankshaft is installed, if grinding has been performed.

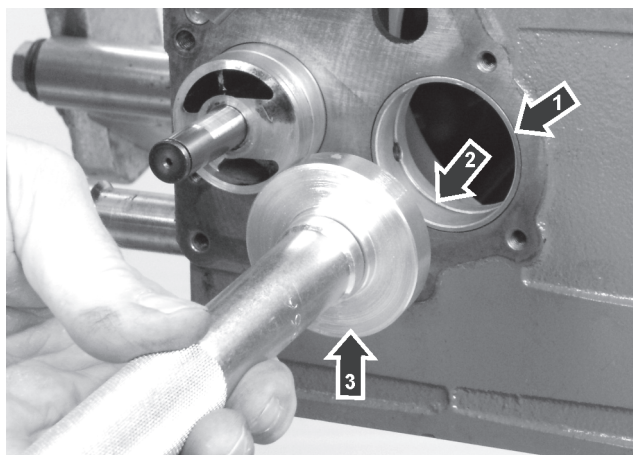

Replacement of front crankshaft bush

1. Remove the bush from the cylinder block.
2. Check that the bush contact surface in the housing has no burrs or deformities.
3. Mark a line across the hole in the housing and the bush with a marker pen. Oil the outside of the bush and the contact surface in the housing.
4. Place the bush (1) in the cylinder housing.

IMPORTANT! Place the bush so that the oil hole is correctly positioned in the cylinder block. The oil groove (2) in the bush must be furthest in.

Tap the bushing in with a suitable mandrel (3) until it lines up with the cylinder block.

5. Check that the oil channels are open are pressing in. Check also that the inner diameter of the bush is the same as the crankshaft diameter.

Checking the big end bearing clearance

Special tools: 856 927

The big-end bearing radial play can be checked by using plastigauge 856 927 as follows:

1. Wipe off any oil from the big end bearing and big end journal. Apply a piece of plastigauge the same length as the width of the bearing along the big-end journal. Avoid the oil hole.
2. Mount the con rod and bearing cap (observe the markings) and tighten the conrod bolts.

Tightening torque, please refer to the "Technical Data" chapter.

NOTE! Do not rotate the con rod or crankshaft during measurement, since this spoils the measurement strip.

3. Remove the big end cap and measure the width of the pressed-out measurement putty at the widest point. Use the scale supplied with the plastigauge.

Max permissible big end bearing clearance, please refer to the "Technical Data".

Change the big-end bearing if the bearing clearance exceeds the permissible value. The big-end journal can be ground to an undersize if required and a corresponding oversize bearing shell fitted. The big-end bearings are available in two oversizes.

NOTE! After grinding the bearing journals, check the bearing clearance again before assembly.

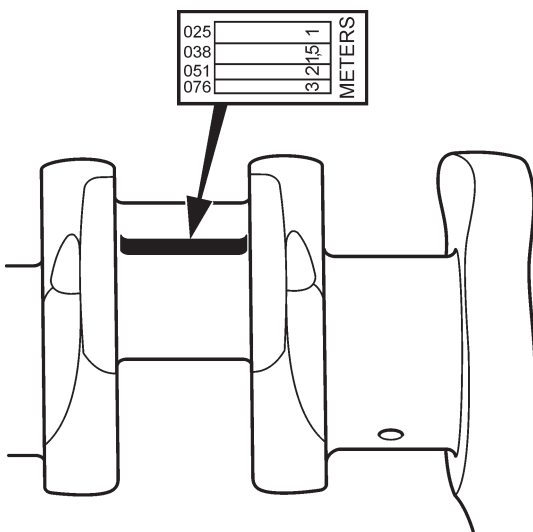
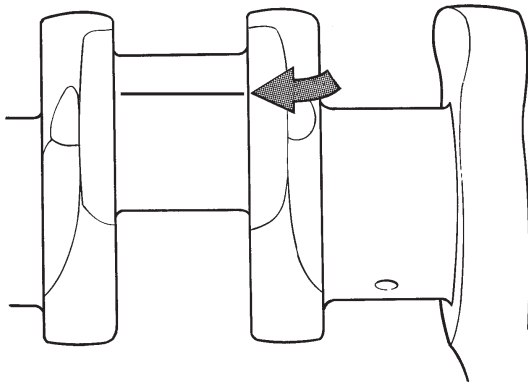

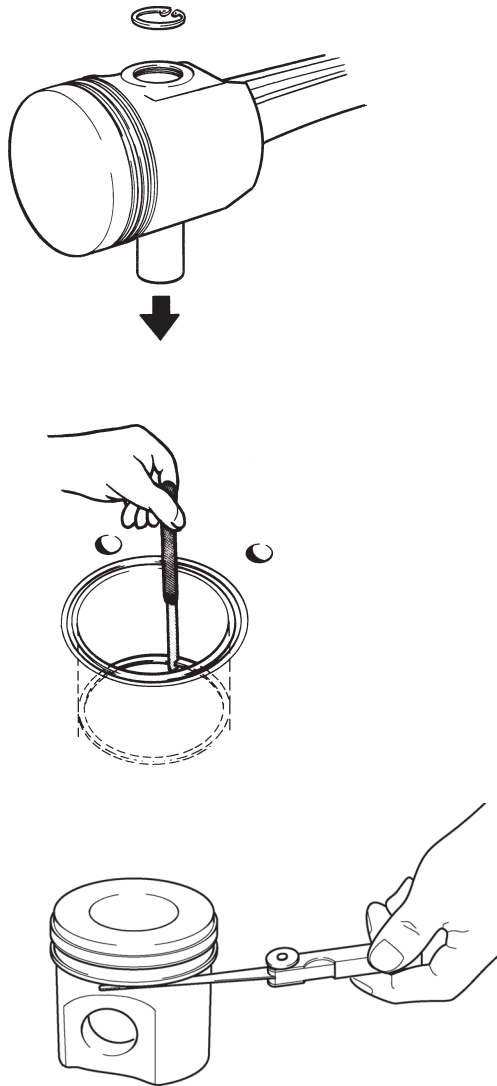

Piston ring inspection and adjustment

1. Remove the piston rings with piston ring pliers.
2. Remove the gudgeon pin circlips and remove the gudgeon pin carefully, with a suitable mandrel.
3. Check that the rings do not bind in the ring grooves.
4. Check the piston ring gap. Push the ring down **below the lower turning point** with a piston. Change the piston ring if the gap exceeds 1.0 mm. Check the piston ring gap with new rings. Please refer to the "Technical Data, specifications" chapter for measurements.

In general, piston rings should be changed if there is any noticeable wear or out-of-roundness in the cylinders, since the piston rings frequently do not end up in the same positions as they had before disassembly.

Oil consumption is also of decisive importance for the point in time when a piston ring change should be done.

5. Check the clearance in the piston ring grooves. Roll the ring in its groove in the piston, and measure the clearance at several points with a feeler gauge. Please refer to the "Technical Data, specifications" chapter for measurements.

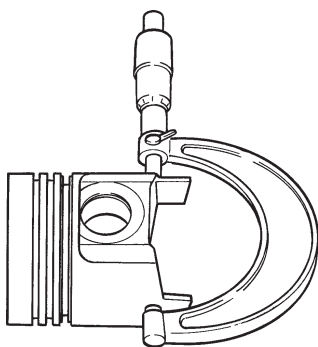

Inspection and measurement of piston and cylinder bore

Check the pistons for cracks and worn piston ring grooves. Change the piston if it has deep grooves in the skirt surface. Likewise, if the piston has one or more cracks in the gudgeon pin hole. If any such damage is found, the injection equipment should also be checked.

Measure the piston diameter with a micrometer at right angles to the gudgeon pin hole and 10 mm from the bottom edge of the piston. Then measure the cylinder bore and calculate the clearance between the cylinder and piston.

Replace the piston if the clearance exceeds the permitted or if the piston diameter is less than permitted value.

Inspecting the con rod

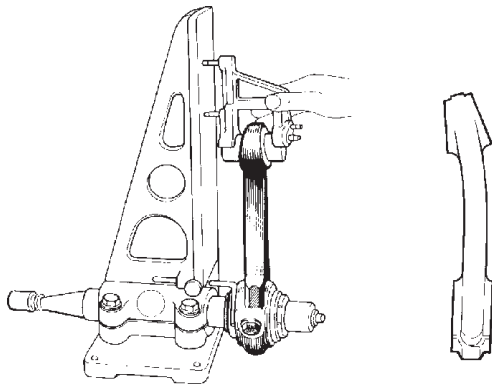

1. Check the con rods for cracking, straightness and twist before considering changing the gudgeon pin bush.

Discard the connecting rod if it is cracked, bent or twisted.

Check the wear of the little end with a gudgeon pin. If the clearance is correct, an oiled gudgeon pin should slide slowly, due to its own weight, through the bush.

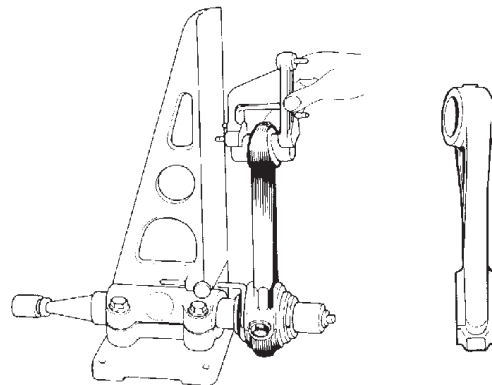

2. Use a new gudgeon pin and measure con rod straightness in a fixture. Max. deviation: 0.15 mm for 100 mm measured length

3. Measure any con rod twist. Max. deviation: 0.20 mm for 100 mm measured length

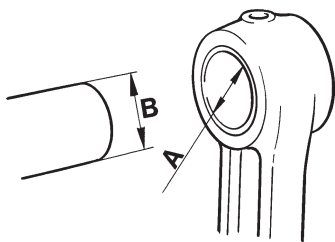

4. Check the end float between the con rod and crankshaft. Change the con rod if the end float exceeds 0.035-0.085 mm.

Also check the con rod bushes. Clearance between the gudgeon pin (A) and con rod bush (B), refer to "Technical data".

Replacing con rod bushes

1. Press the old bush out.
2. Press the new bush in.

NOTE! Make sure that the oil hole in the bush lines up with the drilling in the con rod. Draw a line across the hole in the con rod and the bush, with a felt tip pen. Check that the oil duct is open after pressing.

3. Broach the bush and measure the con rod with an internal dial gauge.

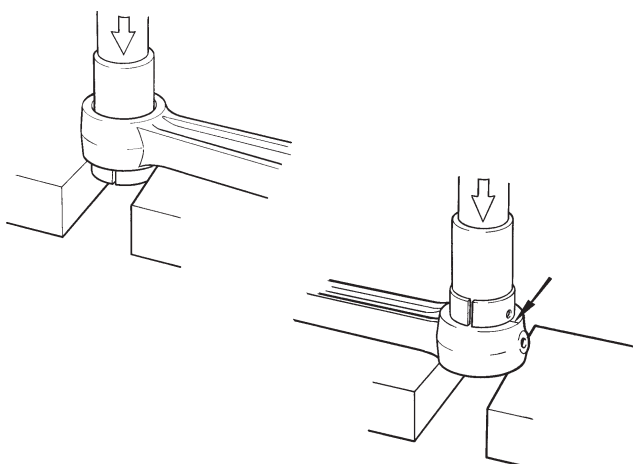

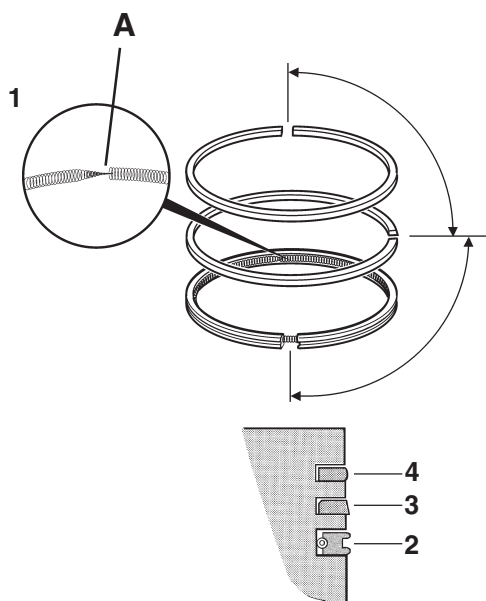
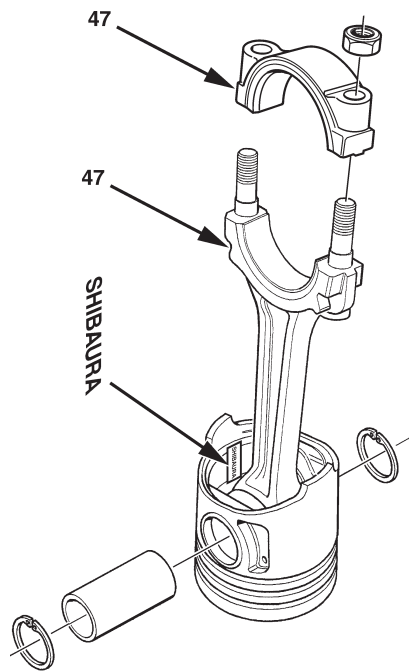
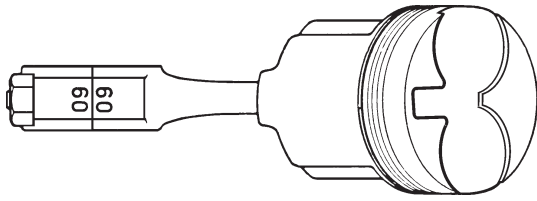

Assembling the piston, piston rings and con rod

1. Install one of the circlips in the piston.
2. Oil the gudgeon pin and con rod bush.
3. Heat the piston to approx. 100 °C. Place the piston and con rod so that the marks align.

The marking on the con rod and the "SHIBAURA" marking inside the piston must face the same way.

Slide the gudgeon pin in.

NOTE! It should be possible to slide the gudgeon pin in easily. It must not be driven in.

4. Install the other circlip.
5. Check that the con rod is not tight on the gudgeon pin bearing.
6. Check the big end bearing clearances. Please refer to "Inspecting the crankshaft" and "Inspecting the main and big end bearings".
7. Check the piston ring gap in the cylinder bore and that the rings do not bind in the piston ring grooves.

8. Install the piston rings on the pistons, using piston ring pliers. Letters or markings on ring surfaces must always be turned so that the marking faces upwards.

Install the oil scraper ring first. Put the expansion spring (1) for the oil scraper ring in the lower piston ring groove, with the location dowel (A) inside both ends of the spring. Check that the ends of the expansion spring do not overlap. Install the oil scraper ring (2) above the expansion spring. Check that the ring gap is displaced 180° from the guide pin.

Install the ring with the tapered surface (3) in the center piston ring pair so that the marking faces the piston crown.

Install the upper ring (4) with the marking upwards.

Check that the ring gaps are displaced 90° from each other.

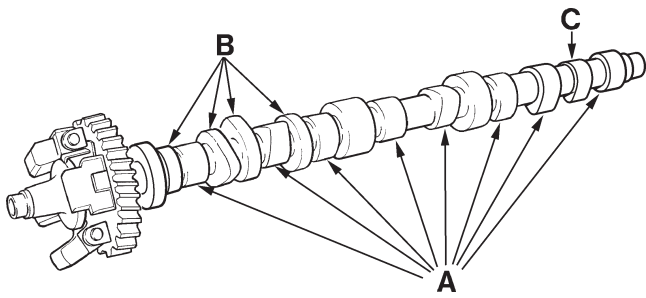

Measuring the camshaft

Cam height (inlet and exhaust), "A" 33.7 mm

Cam height "B" (for injection pump) 41.8 mm

Cam height "C" (for feed pump) 30.0 mm

Change the camshaft if the wear limits have been exceeded.

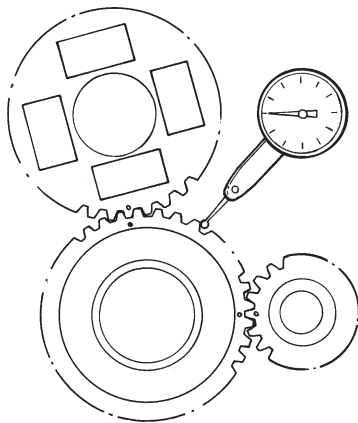

Inspection of timing gears

Special tools: 999 9683

Clean the gears and other parts of the timing system and check them carefully. Replace gears that are badly worn or damaged.

Check the backlash with feeler gauges or a dial gauge, special tool 999 9683.

Max. permitted backlash: 0.25 mm. If the backlash exceeds the permitted value, then all gears in the timing system must be replaced.

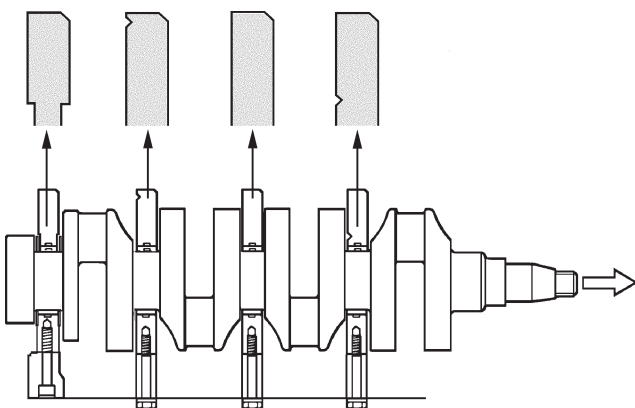

Installing the crankshaft

Special tools: 998 9876, 999 9696

1. Check the cleanliness of the crankshaft drillings and bearing surfaces, engine block and bearing caps. Check that the bearing shells and their beds do not have any burrs or upsets.
2. Place the main bearing shell in position in the bearing cap. The bearing shells have an oil groove that should be placed in the **upper** bearing cap. **Check that the lubrication holes in the upper bearing shells are centered on the oil ducts.**
3. Oil the bearing and main bearing journal and mount the bearing cap in its correct place. The chamfered edge shall face forwards on all bearing caps.

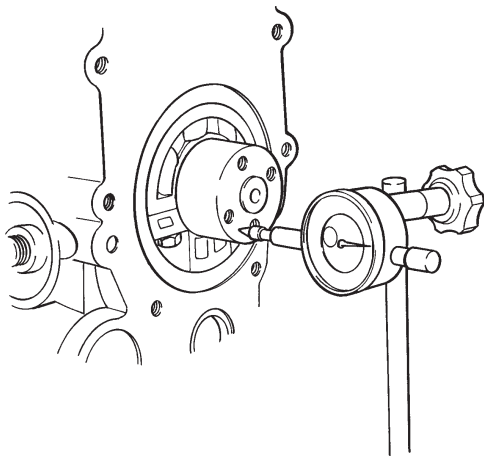
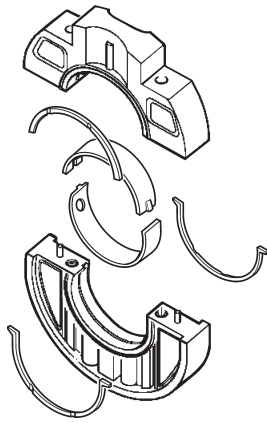

4. Place the thrust washers in the rearmost bearing cap (flywheel side) with the oil groove towards the crankshaft.
Torque the bearing caps, please refer to the "Technical Data" chapter for tightening torque.
5. Carefully lift the crankshaft into position in the cylinder block.

Note. Tape the crankshaft gear before lifting the crankshaft into place, to prevent the gear teeth from damaging the front bearing.

6. Torque the main bearing caps in the engine block. Tightening torque, please refer to the "Technical Data" chapter.

7. Check that the end float does not exceed 0.5 mm by using a special tool, magnetic stand 999 9696 and dial gauge 998 9876.

Mounting pistons in cylinders

Note. After replacing the crankshaft, piston or gudgeon pin, the weight difference between con rods with piston and piston rings shall not exceed 10 g between cylinders.

1. Lubricate the pistons and piston rings with engine oil beside the rings, so that the oil finds its way into the piston ring grooves. Turn the piston rings so that the ring gaps are displaced 90° from each other.

Make sure that no piston ring gap is placed in line with the gudgeon pin.

2. Place the bearing shells in position in the con rods and bearing caps. Oil the bearing journals with engine oil.

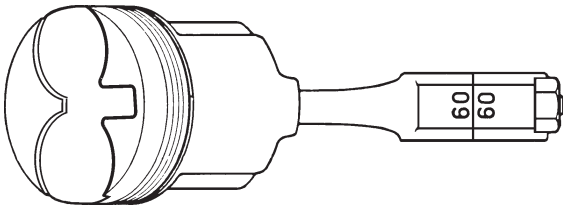

3. Check that the markings on the piston crown or inside the piston line up with those on the con rod.
Use a piston ring compressor and install the piston with con rod in its cylinder, starting with cylinder no. 1 (forwards).
The con rod with the **lowest number** shall be mounted first (in cyl. no. 1) and the con rod with the highest number closest to the flywheel.
The con rods shall be turned so that the mark (number/colorsplash) is facing "towards the injection pump" (camshaft side).
4. Mount the bearing cap and tighten the con rod bolts. Tightening torque, please refer to the "Technical Data" chapter. Bearing caps must be installed so that the number markings/paint marks on con rod and cap coincide.
Undamaged con rod bolts do not need to be changed, they can be put back again.
5. Mount the oil suction pipe and oil strainer. Tightening torque, please refer to the "Technical Data" chapter. Use a new O-ring.
6. Install the sump with a new gasket. Tightening torque, please refer to the "Technical Data" chapter.

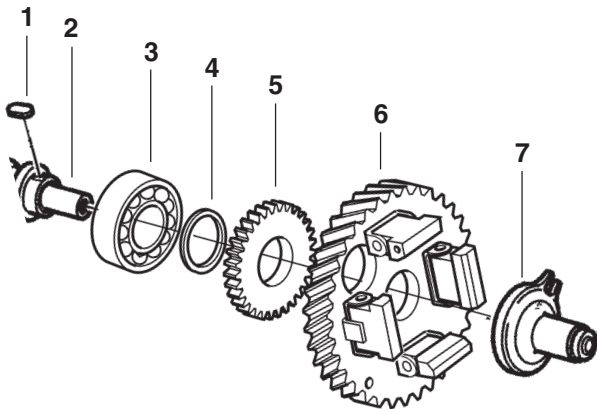

- | | |
|-----------------|---------------------|
| 1. Woodruff key | 5. Gear wheel |
| 2. Camshaft | 6. Camshaft gear |
| 3. Bearing | 7. Regulator sleeve |
| 4. Spacer | |

Installing the camshaft

The parts of the camshaft are mounted as illustrated.

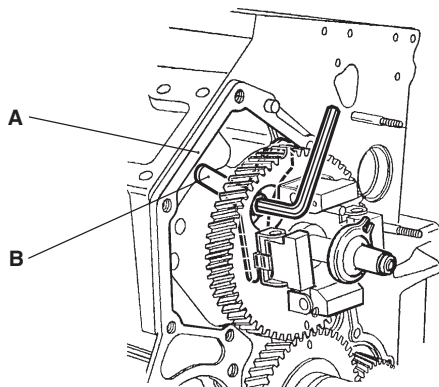

1. Install the front plate (A) with a new gasket. Tightening torque, please refer to the "Technical Data" chapter.
2. Oil the camshaft bearing surfaces and carefully lift the camshaft into place, complete with drive gear and regulator weights.
Note. Be careful to avoid damaging the bearings, bearing tracks and camshaft lobes.
3. Install the camshaft lock washer (B) in the correct position and tighten it. Tightening torque, please refer to the "Technical Data" chapter.

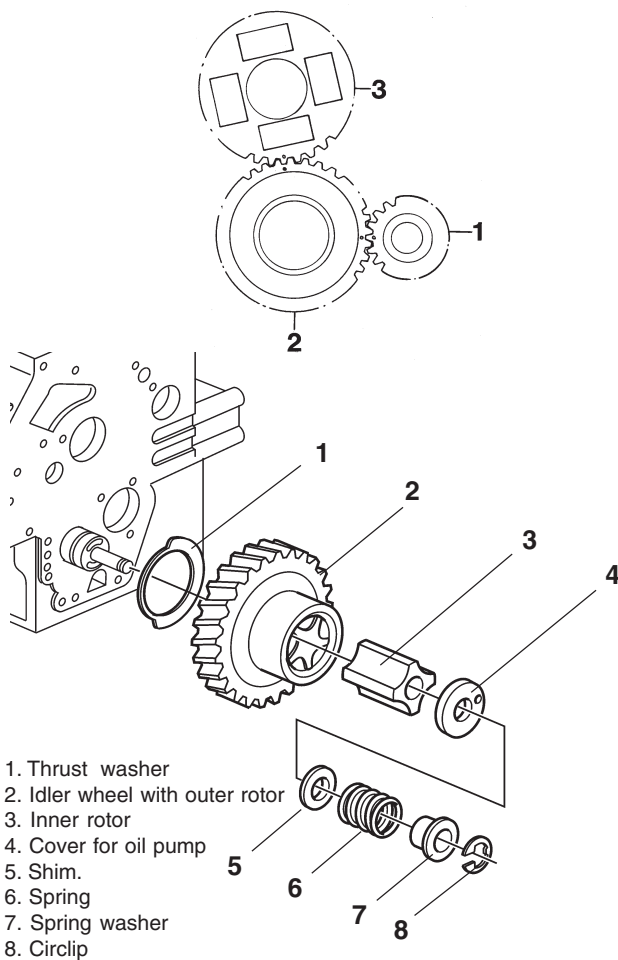

Mounting and installation

Gears that are of importance in the timing gear assembly are marked as follows:

Crankshaft gear (1) and idler gear (2) are marked with a punch mark.

The idler gear (2) and camshaft gear (3) with a punched line in front of a tooth and tooth groove respectively.

1. Fit the Woodruff key in place and mount the crankshaft gear.

⚠ IMPORTANT! The components must be oiled before installation.

⚠ IMPORTANT! Make sure that the gear wheel markings coincide.

2. Install the thrust washer (8) on the idler wheel shaft stub. Install the idler gear so that the marks align.

NOTE! Do not turn the crankshaft before the timing gear cover has been installed.

3. Install the inner rotor and cover to the oil pump. Install shims, spring, spring washer and lock washer.

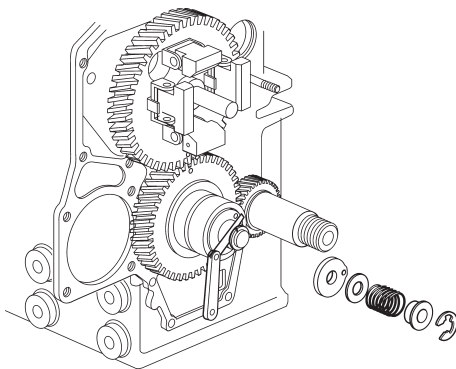

4. Adjust the oil pump end float to 0.10-0.15 mm. Shims are available in thicknesses 0.10; 0.15; 0.20 and 0.50 mm.

5. Install a new crankshaft seal.

6. Center the cover in front of the oil pump.

Note. Check that the spring pin in the timing gear cover can engage in the hole in the oil pump cover. Turn the cover back and forwards, and center it in the mid position. The stop arm must be turned and held in place while the timing gear cover is positioned.

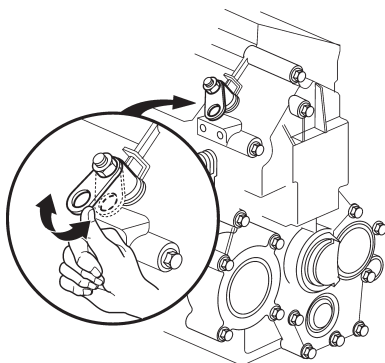

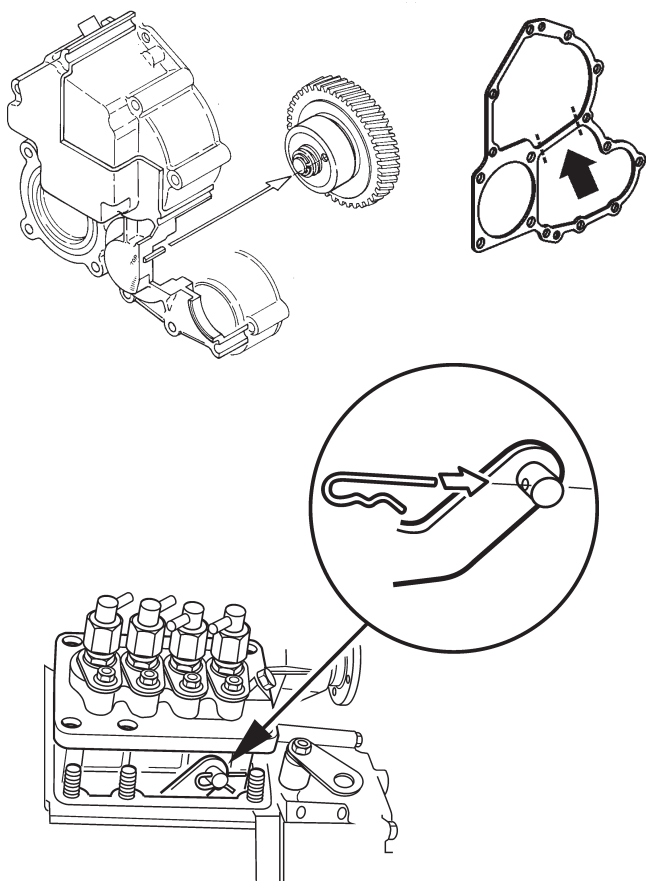

7. Place a new gasket on the timing gear cover.

NOTE! If the gasket contains a center part, this must be cut away.

Install the timing gear cover with the new gasket. Check that the start spring is in position in the timing gear cover and is connected to the regulator arm (link arm). Push the regulator arm through the hole in the cylinder block.

Screw the timing gear cover down.

8. Turn the stop arm clockwise and connect to the injection pump. Fit the clip.

NOTE! Be careful to ensure that the shim that was placed underneath the injection pump flange is put back, before the pump is placed in the block (applies when the pump has been removed).

9. Tighten the injection pump, tightening torque refer to "Technical data".

10. Fit the key into the crankshaft and install the crankshaft pulley. Tightening torque, please refer to the "Technical Data" chapter.

11. Connect the fuel hose to the injection pump.

12. Check the injection timing (crankshaft position) in cases where a new complete camshaft has been installed or if a new cylinder block is used.

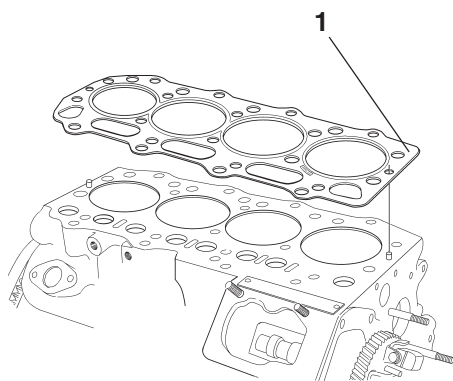

Installing cylinder head

1. Clean the cylinder head and cylinder block surfaces. Remove any rust and carbon from bolt holes and from the threads on the cylinder head bolts.

2. Install the valve lifters.

Note Install the valve lifters in their original positions.

3. Insert the cylinder head gasket with the mark (1) upwards.

NOTE! The new gasket must be of the same thickness as the old one.

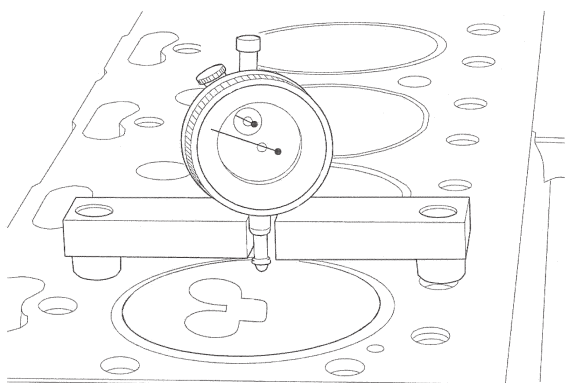

If a piston, con rod, crankshaft or engine block has been changed, new measurement must be done.

The height difference between pistons and cylinder head	Gasket thickness
-0.45 to -0.30 mm	0.4 mm
-0.29 till -0.20 mm	0.5 mm

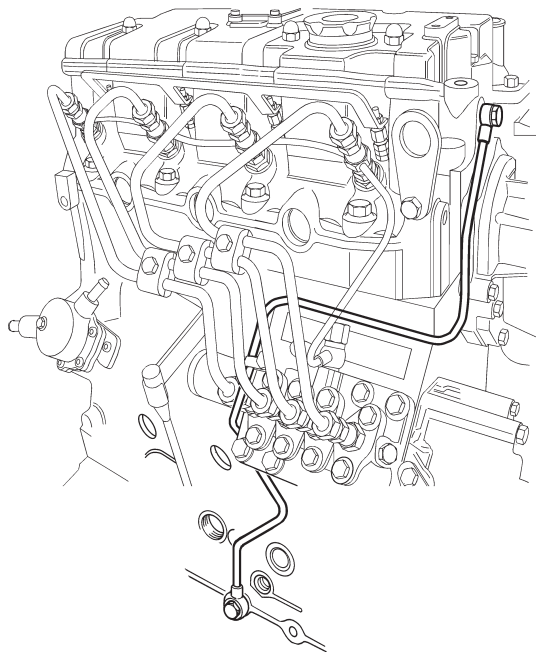
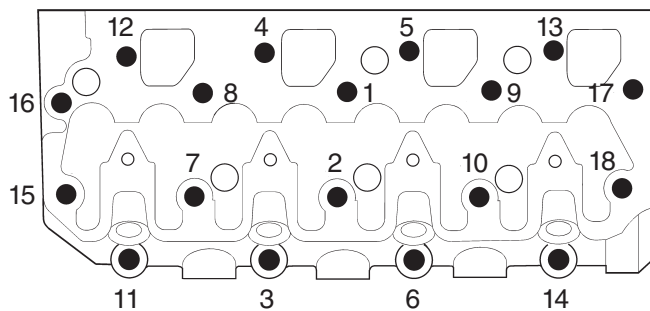

4. Dip them completely (even bolt heads) in rust preventative 116 1346 and let them run off on a net. The bolts should have stopped dripping when they are installed (otherwise oil could well up and be regarded as leakage).

⚠ IMPORTANT! The bolts are phosphated and must not be cleaned with a steel wire brush. If the cylinder head is painted, the contact surfaces for the cylinder head bolts must be free from paint. The clamping force in the joint could otherwise be very poor.

5. Check that the dowels (guides) are fitted to the block.
6. Tighten the cylinder head bolts in three steps as follows. Refer to tightening diagram.

1st tightening	30 Nm
2nd tightening	70 Nm
Final tightening:	100 ± 2.5 Nm

7. Install the copper injector washers.
Install the injectors. Tightening torque refer to "Technical data".
8. Install the pushrods, valve caps and rocker arm mechanism with gasket. Tightening torque, please refer to the "Technical Data" chapter.
9. Install the oil pressure pipe between the block and rocker arm mechanism together with the oil pressure sensor. Install the oil pressure valve.
Tightening torque, please refer to the "Technical Data" chapter.
Turn the crankshaft round a couple of rotations.
10. Adjust the valve clearances. Tightening torque, please refer to the "Technical Data" chapter.
11. Install the valve cover.
12. Install the injection pump hollow bolt and banjo union with new copper washers.
13. Install new copper gaskets and install the return fuel line. Tighten the nuts and connect the return pipe.
14. Install the delivery pipes, tightening torque refer to "Technical data".
15. Install the glow plugs and power rail.
16. Install the circulation pump, tightening torque refer to "Technical data".
17. Clean the sealing ring seat in the cylinder block and the contact surface of the plate. Install the rear crankshaft seal.

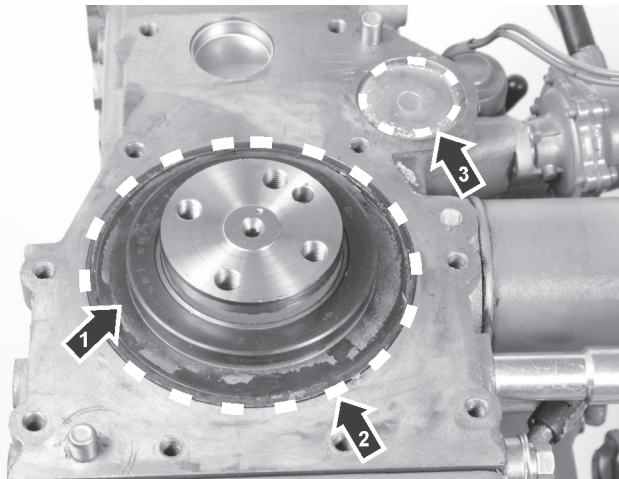

18. Check that the spaces for the seal on the engine block and crankshaft are clean. Apply grease to the sealing edges and fit the seal (1). Apply an even layer of sealant 840 879 around the seal (2) and camshaft (3).

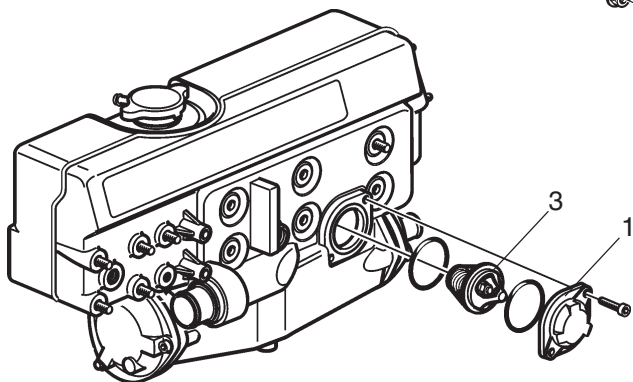
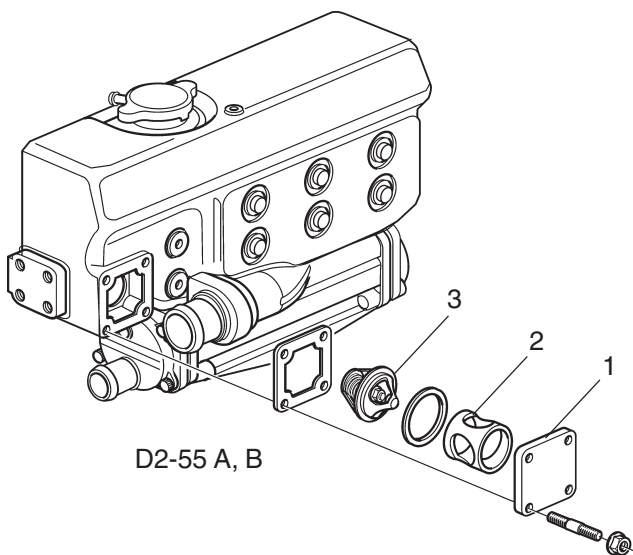

19. Install the plate, flywheel according to previous markings, the elastic coupling and the flywheel housing, tightening torque refer to "Technical data".
20. Install the heat exchanger. Mount the hoses on the heat exchanger and coolant pump. Tighten the hose clamps.
Install the oil pipe to the turbo and charge air cooler (only D2-75).
Install the turbo (only D2-75).
21. Install the sea water pump.
22. Install the fuel filter bracket and feed pump, tightening torque refer to "Technical data". Mount hoses and tighten hose clamps.
23. Install the starter motor and alternator together with the front engine mounting.
24. Connect the hose to the sea water pump and tighten the hose clamp. Install the exhaust pipe.
25. Install the electronics box, install the connectors and other electrical connections.
26. Install the induction silencer.
27. Fill with oil, refer to "Technical data". Fill with coolant, refer to "Technical data".
28. Connect the battery cables. Open the fuel taps and the sea cock. Start the engine and check carefully that no leakage occurs.

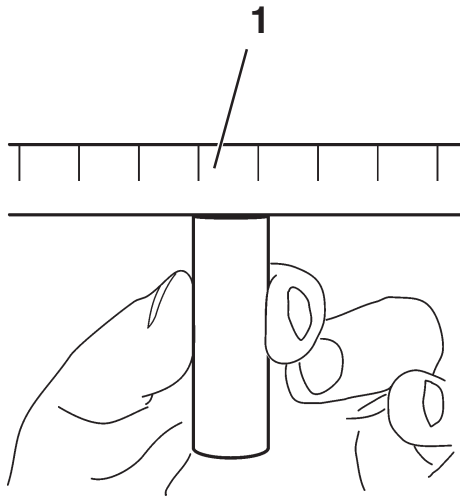

Camshafts and valve lifters, inspection

Check, using a steel ruler (1), that valve lifter contact surface facing the camshaft is convex or flat. If the surface is concave, change the valve lifter.

If the valve lifter is worn all across the lifting surface, the valve lifter should be scrapped. "The ditch" shows that the lifter has not been turning.

A dark line on the outside of the valve lifter shows that the surface is not worn, on the other hand. The condition of the valve lifters determines whether it is necessary to check for camshaft wear.

Check that the lifting surfaces on the camshaft and the valve lifters do not have large areas of pitting damage. Pitting damage can occur for various reasons. The damage is caused when small pieces of metal loosen from the hardened surface. Lifters and camshafts with minor pitting damage can be used. Pitting damage seldom become worse.

Check that the camshaft bearing surfaces and cam curves are not abnormally worn.

Change the camshaft if major damage or wear occurs.

NOTE! When replacing camshaft, all valve lifters should be replaced too.

Guidelines for replacement

In normal conditions, un-evenness may occur on the camshaft lobes in the engine. This does not mean that the camshaft has to be changed. These marks do not have any negative influence on either engine performance or durability of the engine and its components.

The next pages shows examples of acceptable wear and non-acceptable wear.

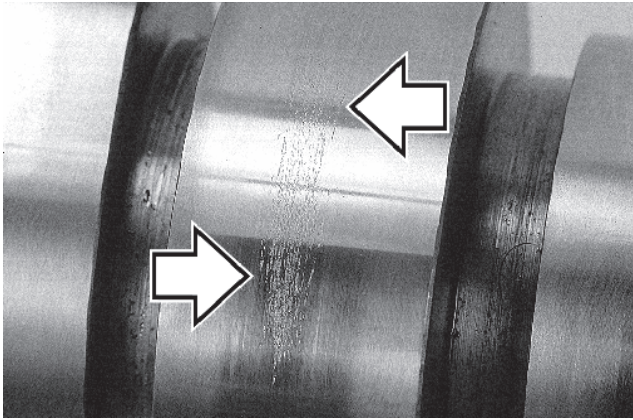

Acceptable wear.

The camshaft does not need to be changed.

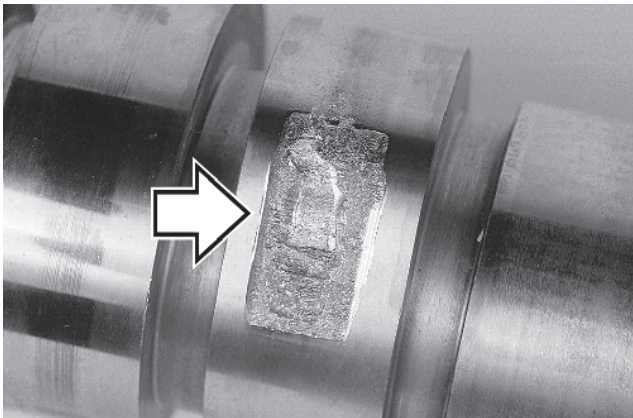
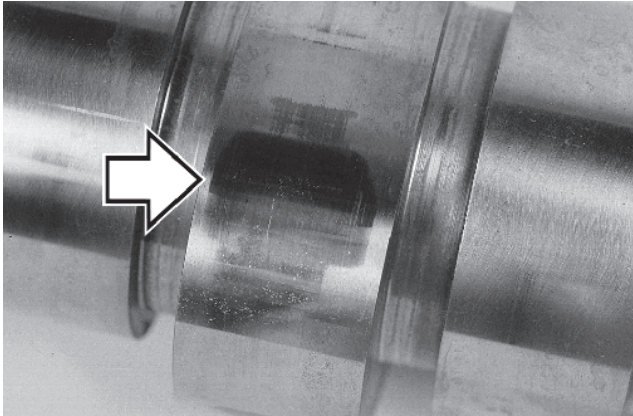

Unacceptable wear.

NOTE! Camshaft with associated rocker arms must be replaced.

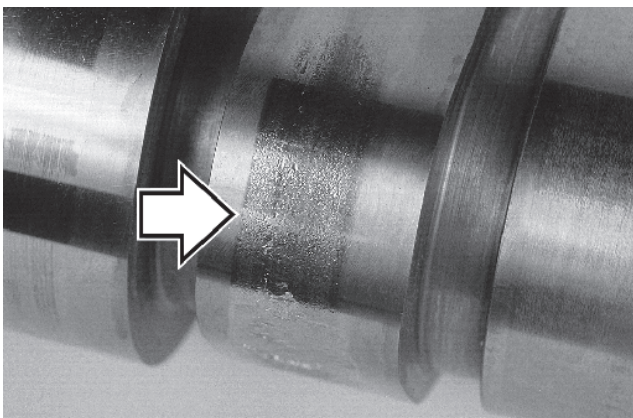

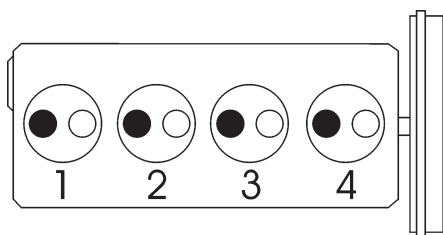

● Inlet ○ Exhaust

Firing order	1	3	4	2
Corresponding cylinder who's valves "overlap"	4	2	1	3

Adjusting valves

NOTE! The clearances shall never be checked while the engine is running, but on a stationary cold engine.

Valve clearances: Inlet and exhaust: 0.2 mm.

1. Remove the valve cover.
2. Turn the engine in normal direction of rotation until no.1 piston is at TDC after the compression stroke. The valves on cylinder 4 overlap.
3. Check and adjust the valve clearances for cyl. no. 1. Turn the engine in normal direction of rotation a half turn and check the clearances for cyl. no. 3, the valves on cylinder 2 overlap.

Check the clearances for the remaining cylinders in firing order.

4. Replace seal. Clean the valve cover and install it. Test run the engine and check that no oil leakage occurs.

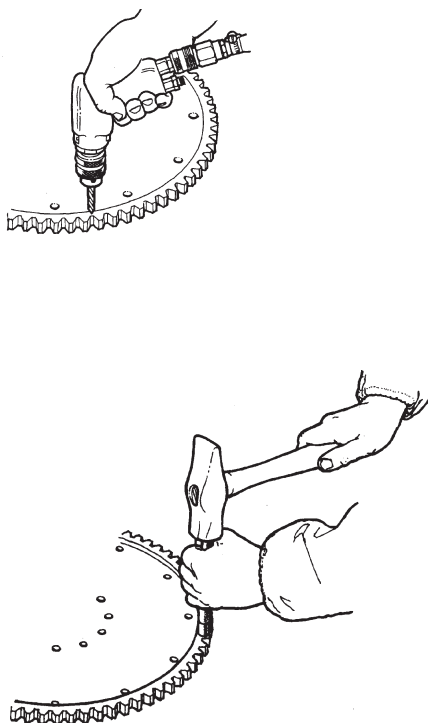

Replace ring gear on flywheel

1. Mark the flywheel position on the crankshaft (simplifies installation). Remove the flywheel.
2. Drill a hole or two in a tooth root on the ring gear. Crack the ring gear with a chisel at the drilled holes and remove it.
3. Clean the ring gear contact surface on the flywheel with a wire brush.
4. Heat up the new ring gear in an oven (120-150°C) so that the ring gear is heated evenly.
5. Place the heated ring gear on the flywheel and drive into place with a hammer and soft mandrel. The ring gear should then cool naturally.
6. Clean the contact surfaces on the flywheel and crankshaft. Check the rear crankshaft seal. Change as necessary.
7. Install the flywheel according to previously made marks.

Tightening torque, please refer to the "Technical Data" chapter.

Replacement of rear crankshaft seal

The seal consists of a rubber ring and is accessible once the plate behind the flywheel housing and the elastic coupling, flywheel* and flywheel housing have been removed.

***Note.** Mark the flywheel position on the crankshaft (simplifies installation).

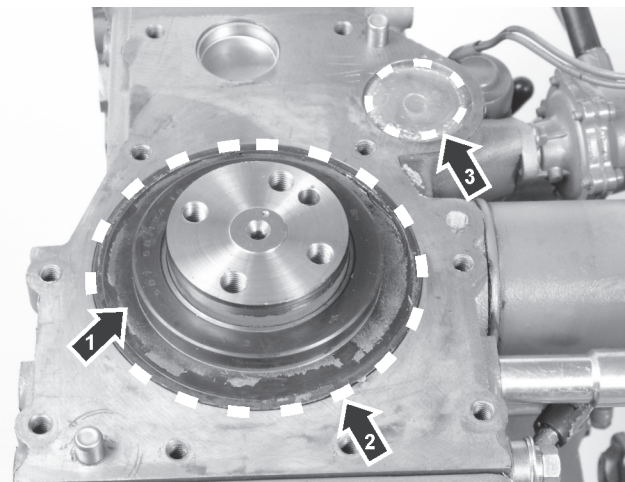

1. Remove the crankshaft rear seal (1). Check that the spaces for the seal on the engine block and crankshaft are clean. Apply grease to the sealing edges and install the seal.
2. Apply an even layer of sealant 840 879 around the seal (2) and camshaft (3).
3. Install the flywheel, the elastic coupling, the adapter plate and the flywheel housing.

Tightening torque, please refer to the “Technical Data” chapter.

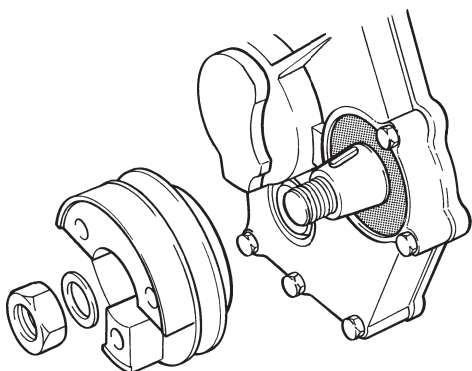
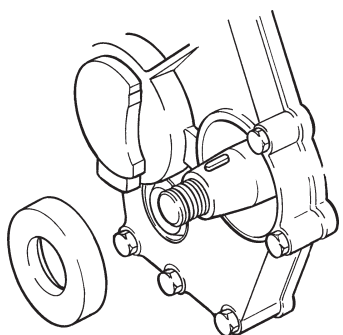

Replacement of front crankshaft seal

The seal consists of a rubber ring and can be replaced once the crankshaft pulley has been removed. Use puller 999 5919 to remove the seal.

1. Remove the key and tape over the keyway.
2. Apply grease to the new seal and install it with a suitable socket.
3. Remove the tape. Install the key and crankshaft pulley.

Tightening torque, please refer to the “Technical Data” chapter

Group 22 Lubrication system

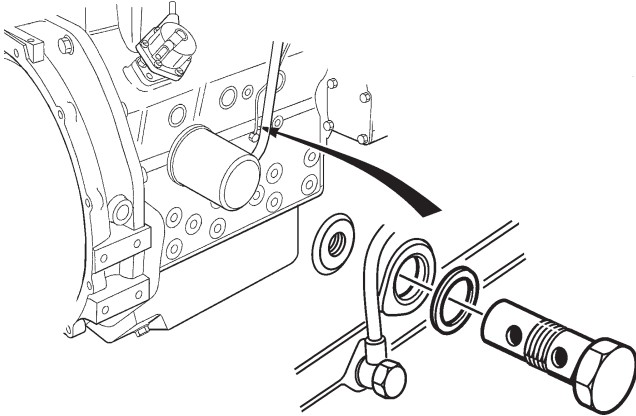

Repair Instructions

Checking lubrication oil pressure

The lubrication oil pressure can be checked by connecting a manometer with a hose to the connection for the oil pressure switch (thread size in cylinder block = 1/8"). For the correct pressure at operating speed and temperature, refer to "Technical data".

If the oil pressure is too high or too low, first try replacing the reduction valve and then check the oil pressure again.

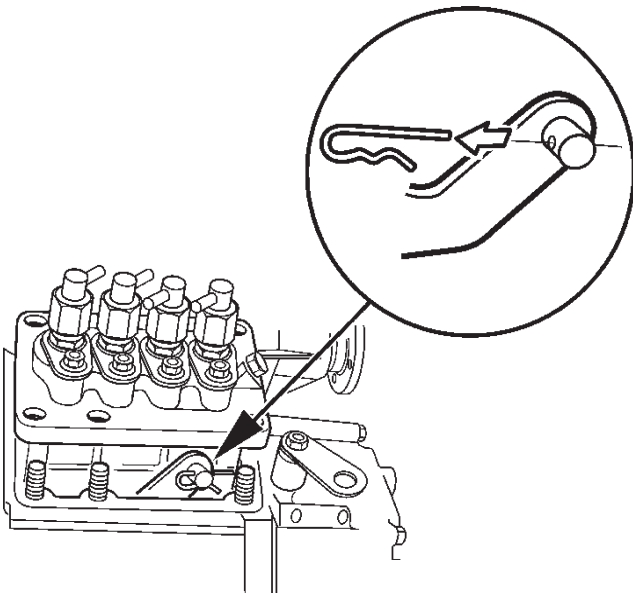

Oil pump

Removing oil pump

1. Remove the injection pump (19). Remove the fixing screws and nuts on the pump. Turn the stop lever clockwise and carefully lift the pump, to make the lock clip on the regulator arm accessible.

Remove the lock clip and free the regulator arm.

⚠ IMPORTANT! Be careful when disassembling the injection pump, avoid damaging or bending the lever.

NOTE! Retain any shims from beneath the injection pump flange. Use the same thickness of shims when re-installing, unless the camshaft, engine block or injection pump have been changed.

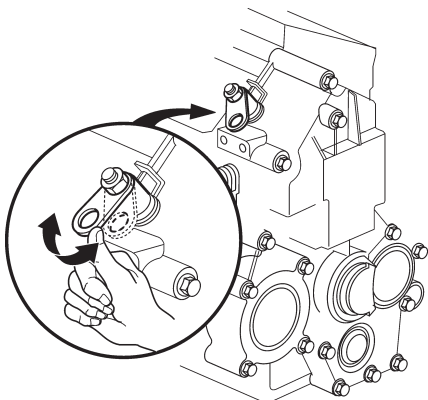

2. Remove the pulley, use special tool 885 820 and 3 pcs. M10x40 mm bolts. Remove the timing gear cover. Load the stop arm so that the springs on the inside of the housing do not come out of position or spring out.

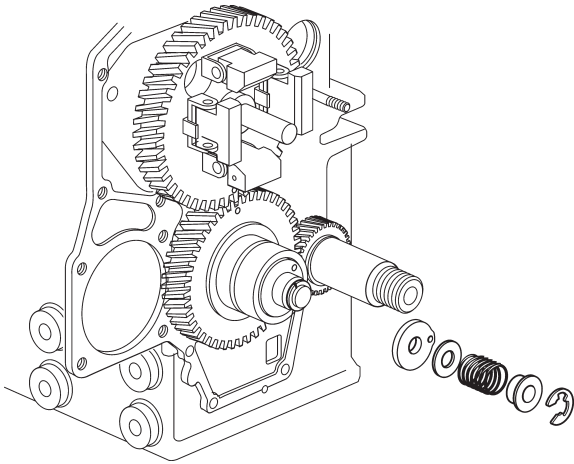

3. Remove the idler lock ring. Save the sleeve washer, spring and shims.
Lift away the idler gear complete with cover and oil pump. Note the thrust washer behind the oil pump.

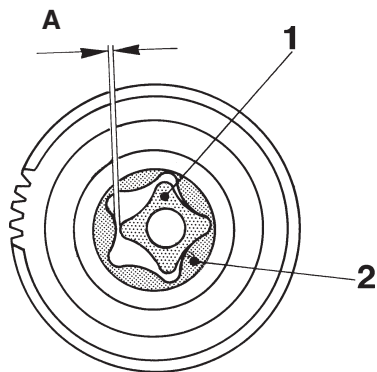

Inspection of oil pump

1. Check that the oil pump's cover and the outer and inner rotors are not worn or damaged.
2. Check the clearance (A) between the inner (1) and outer (2) rotor. Max. permitted clearance 0.25 mm.
3. Check the idler gear bearings and stub axle. If necessary these shall be replaced. Refer to "Oil pump bearing, overhaul".

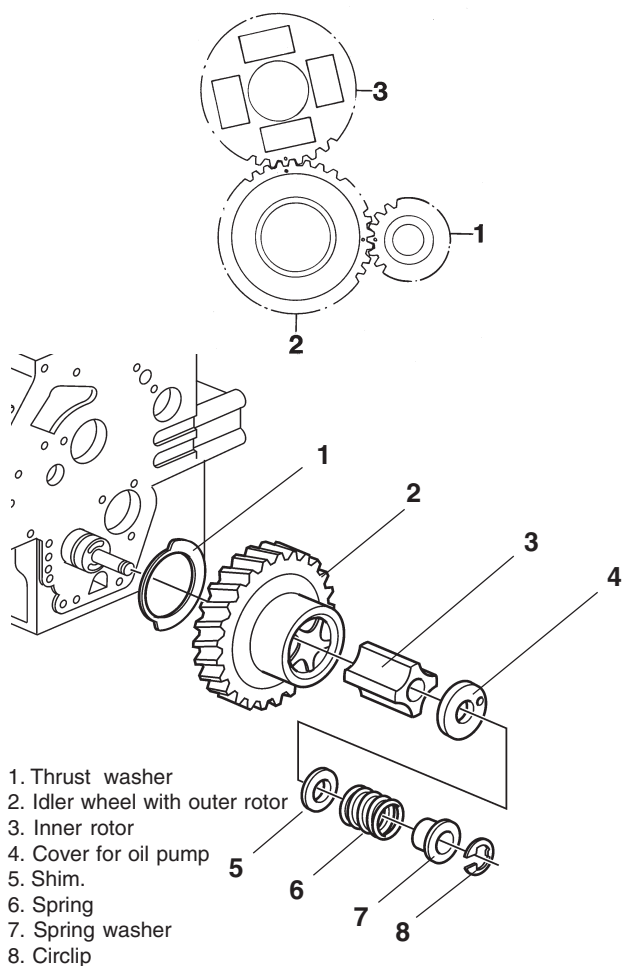

Installing the oil pump

Gears that are of importance in the timing gear assembly are marked as follows:

Crankshaft gear (1) and idler gear (2) are marked with a punch mark.

The idler gear (2) and camshaft gear (3) with a punched line in front of a tooth and tooth groove respectively.

⚠ IMPORTANT! The components must be oiled before installation.

⚠ IMPORTANT! Make sure that the gear wheel markings coincide.

1. Install the thrust washer (8) on the idler wheel shaft stub. Install the idler gear so that the marks align.

NOTE! Do not turn the crankshaft before the timing gear cover has been installed.

2. Install the inner rotor and cover on the oil pump. Install shims, spring, spring washer and lock washer.

3. Adjust the oil pump end float to 0.10-0.15 mm. Shims are available in thicknesses 0.10; 0.15; 0.20 and 0.50 mm.

4. Install new crankshaft seal.

5. Center the cover in front of the oil pump.

NOTE! Check that the spring pin in the timing gear cover can engage in the hole in the oil pump cover. Turn the cover back and forwards, and center it in the mid position. The stop arm must be turned and held in place while the timing gear cover is positioned.

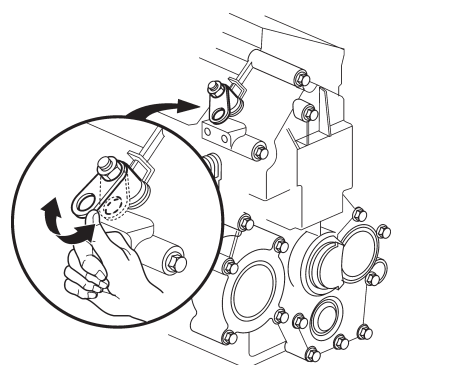

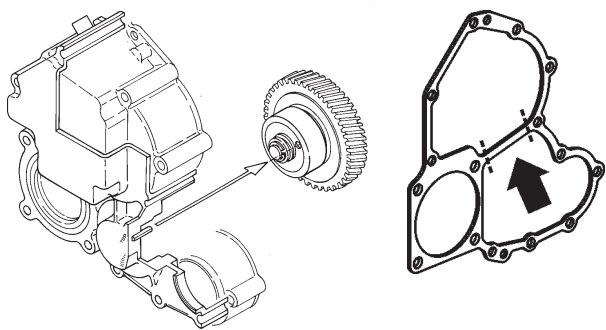

6. Install a new gasket on the timing cover.

NOTE! If the gasket contains a center part, this must be cut away.

Install the timing gear cover with the new gasket.

Check that the start spring is in position in the timing gear cover and is connected to the regulator arm (link arm). Push the regulator arm through the hole in the cylinder block.

Screw the timing gear cover down.

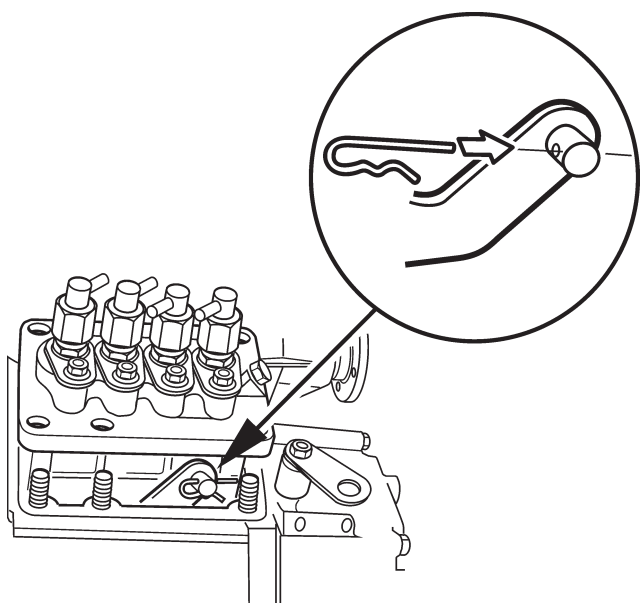

7. Turn the stop arm clockwise and connect to the injection pump. Fit the clip.

NOTE! Be careful to ensure that the shim that was placed underneath the injection pump flange is put back, before the pump is placed in the block (applies when the pump has been removed).

8. Tighten the injection pump, tightening torque refer to "Technical data".

9. Fit the key into the crankshaft and install the crankshaft pulley. Tightening torque, please refer to the "Technical Data" chapter

10. Connect the fuel hose to the injection pump.

11. Check the injection timing (crankshaft position) in cases where a new complete camshaft has been installed or if a new cylinder block is used.

Oil channels

Clean and flush the oil channels in the engine with cleaning liquid and then with steam or rinsing oil at a pressure of 300-400 kPa in conjunction with a larger engine overhaul. Clean the oil pressure pipe between the cylinder block and cylinder head.

Clean the drilled oil channels in the cylinder block, crankshaft and con rods with a cleaning brush.

Oil pump bearing, overhaul

Special tools: 384 9641

In order to remove the oil pump, the timing gear and crankshaft must be removed.

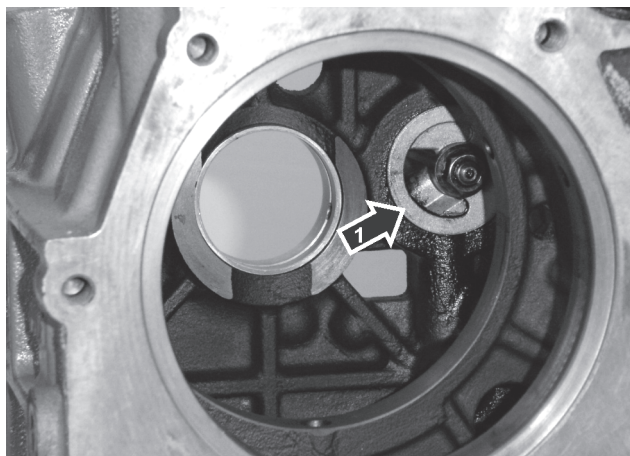

1. Drive out the oil pump bearing section (1) located in the engine block. Tap it out from inside the crankcase.

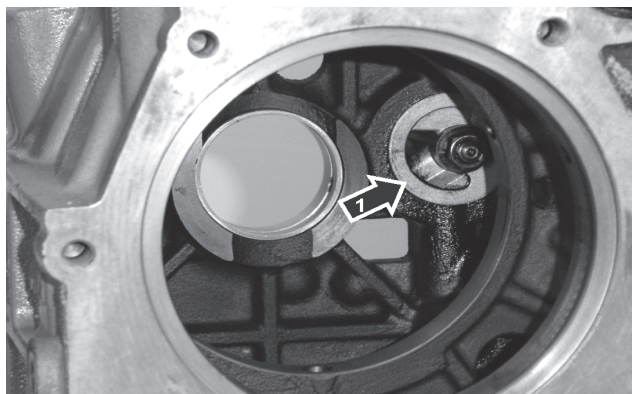

2. Use tool 384 9641. First screw the tool's guide pin (1) into the engine block. Then put the new oil pump bearing (2) into the tool block (3).

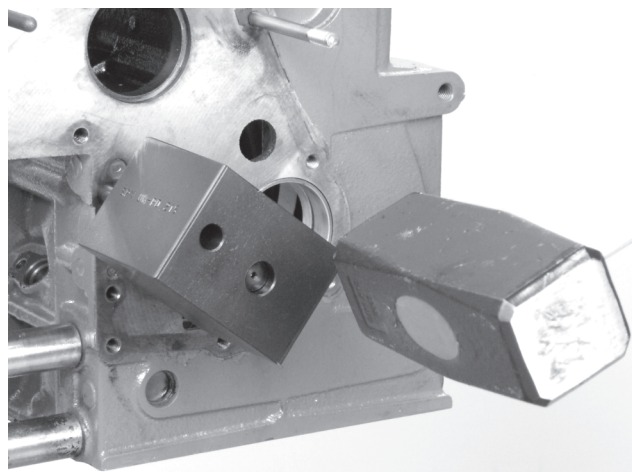

3. Place the tool block with the bearing in place, using the guide pin. Tap in the bearing until the tool bottoms on the engine block.
NOTE! It is important that the engine block surface towards the tool is clean and even.

Group 23 Fuel system

Repair Instructions

Observe the greatest possible cleanliness in work on the fuel system.

Injection pump

Removing the injection pump

NOTE! Repair work that requires work on the injection pump and which can change its settings shall only be performed by a specially trained mechanic who has the necessary equipment at his/her disposal.

All warranties for the engine are forfeit if the seals are broken by unauthorized personnel.

1. Wash the injection pump, injection pipes and the engine closest to the pump very thoroughly.
2. Close the fuel taps. Remove the delivery pipes complete. Release the fuel hose from the pump.

Fit protective plugs to all connections.

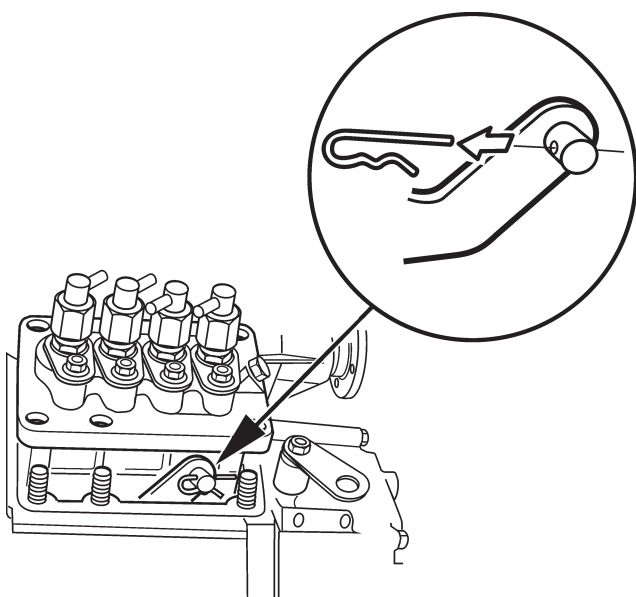

3. Remove the fixing screws and nuts on the pump. Turn the stop lever clockwise and carefully lift the pump, to make the lock clip on the regulator arm accessible.

Remove the lock clip and free the regulator arm.

NOTE! Retain any shims/gaskets from under the injection pump's flange when the pump is lifted from the cylinder block.

4. Send the pump to an authorized diesel workshop for repair if the workshop does not have specially trained personnel with the necessary testing equipment.

Installing the injection pump

Check that the pump is free from faults and if necessary has been tested and approved before installation.

Do not remove the protective plugs before the pipes are to be connected.

1. Insert the injection pump into the cylinder block.

NOTE! Make sure that any shims that were placed under the injection pump flange are in replaced as they were, before the pump is installed on the block.

This normally ensures that the pump settings are correct. If the camshaft complete or the cylinder block have been replaced then the injection pump settings need adjusting. Refer to the next paragraph, "Setting injection timing".

2. Turn the stop arm clockwise and connect the regulator arm to the regulator rod on the pump. Fit the clip. Screw the pump in place.
3. Connect the fuel hose and return fuel line to the pump. Install the delivery pipes.
4. Prime the fuel system and test run the engine.

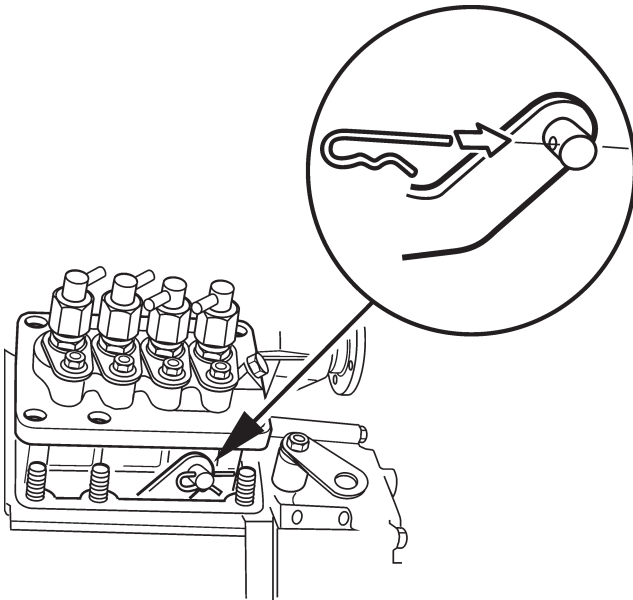

Setting injection timing

1. Remove the delivery pipes and return line.

If the block or the camshaft have been replaced, a 0.5 mm shim shall be placed under the injection pump flange when installing.

2. Remove the front (1st) pressure valve holder. Remove the pressure valve and refit the pressure valve holder.

It is recommended to remove the pump and hold it in an upright position when installing the pressure valve holder.

NOTE! Be aware of the pump element so as not to damage it.

3. Make a drop pipe from i.e. a scrapped delivery pipe and mount it on the pressure valve holder. Place a fuel container under the pressure valve holder drop pipe.

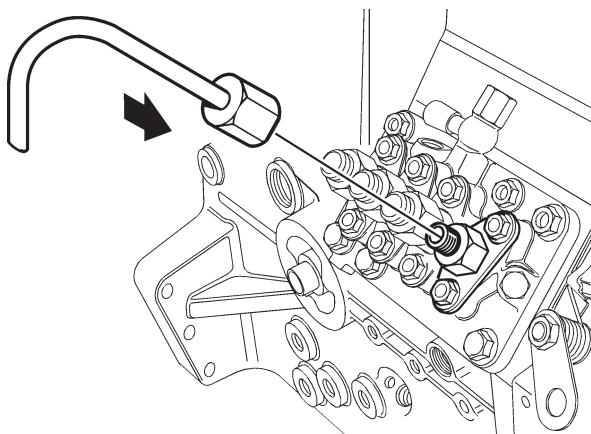

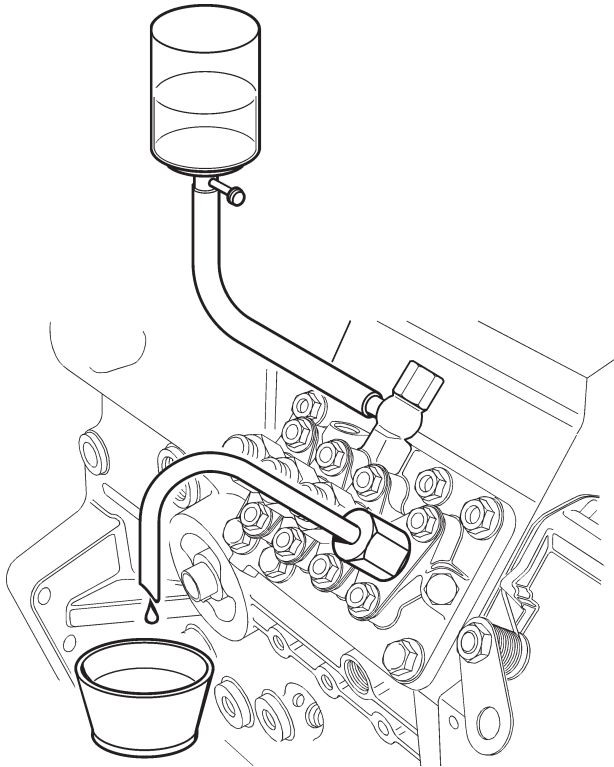

4. Connect a fuel container with stopcock to the inlet of the injection pump. It should hold about 0.7 liter. Use the hose between the fuel filter and the injection pump to connect the fuel container. If everything is correctly arranged, fuel should start to run out of the drop pipe.
5. Turn the crankshaft in normal direction until the piston in cylinder 1 is at TDC, the rocker arms on cylinder 1 should overlap.
Turn the crankshaft another half turn (180°) in the normal direction.
6. Move the actuator arm to maximum position.
7. Turn the crankshaft slowly in the normal direction until the flow is 7 drops/minute, then read off the number of degrees on the crankshaft pulley. If the value read off diverges from the value in technical data, the injection timing must be adjusted.
A 0.1 mm shim alters the injection timing approx. 1°. Thicker shims give later timing and thinner shims give earlier timing.
8. Refit the pressure valve.

Setting the engine speed

Check that the accelerator control functions normally, i.e. the actuator arm (1) is pressed against the low idle stop (2) when the accelerator control is at idle, and is pressed against the full throttle screw (3) when the accelerator control is at full throttle. Adjust the control if necessary. Also check that the air filter is not blocked, and that the air inlet is not blocked.

⚠ IMPORTANT! The engine's fuel volume and speed are set at the factory to give highest power and least environmental impact. These settings must not be disturbed.

NOTE! Seals on injection equipment may only be broken by authorized personnel. Seals which have been broken must be re-sealed.

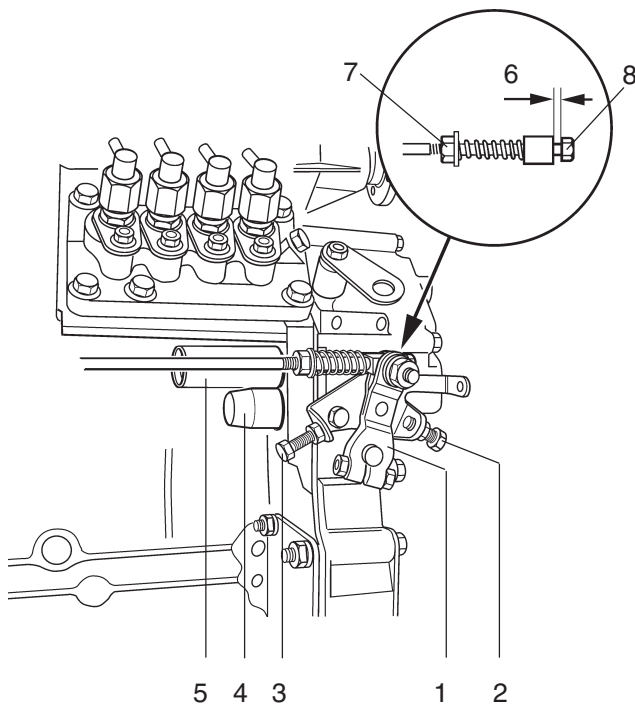

1. Actuator arm
2. Adjustment screw, low idle
3. Stop screw, full throttle
4. Adjustment screw, racing speed
5. Adjustment screw, max. fuel volume
7. Lock nut

Low idle

1. Check that the gap (6) is about 3 mm when the accelerator is in the idle position. If necessary: Undo locknut (7) and adjust screw (8) to give the correct gap.
2. Warm up the engine and check the idle speed with a tachometer (refer to Technical data for the correct idle speed).
3. Adjust to the correct idle speed with adjusting screw (2).
4. Check the gap (3) again as in item 1.

Racing speed (high idle)

Warm the engine up and check the racing speed with a workshop tachometer when the engine is unloaded at full throttle (please refer to "Technical data" for correct racing speed).

Adjust the following as necessary

1. Loosen the stop screw (3) so that it does not limit the movement of the actuator arm (1).
2. Run the engine unloaded at full throttle and adjust to the correct racing speed with adjuster screw (4) (remember to re-seal the screw).
3. Adjust stop screw (3) to give a clearance of 0.1 mm between stop screw (3) and the actuator arm (1) when the throttle control is at the full throttle position.

Feed pump

Removal of the feed pump

1. Clean around the pump.
2. Close the fuel taps. Loosen the fuel connections from the pump.
3. Remove the feed pump from the cylinder block. Empty the pump from fuel.

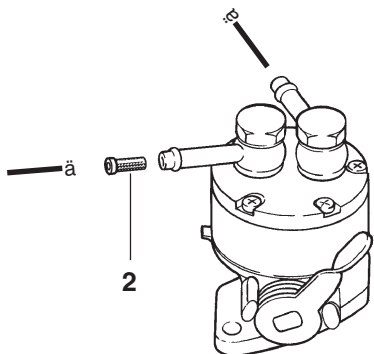

Disassembly and inspection of the feed pump

1. Check that the piston (1) does not bind in the pump housing.

Note. The feed pump's hand pump only functions when the piston is depressed.

2. Remove the strainer (2) from the feed pump's inlet pipe and check that it is not restricted by dirt. Re-install the strainer by pressing it in until a "click" is heard.

3. Check the function in the valve housing (3) before disassembly as follows:

Suck in the inlet (IN), and blow in the outlet (OUT). The function is normal if they seal in both cases.

4. Mark the position of the cover (4), valve housing and pump housing (5).
5. Remove the screws holding the cover. Remove the cover and valve housing.
6. Turn the membrane and piston until the pin (6) in the piston is in front of the groove in the pump housing.
7. Press in the piston and membrane (7). Press the pin out of the piston and remove the piston, membrane and springs from the pump housing.
8. Check that the membrane is undamaged and shows no cracks.

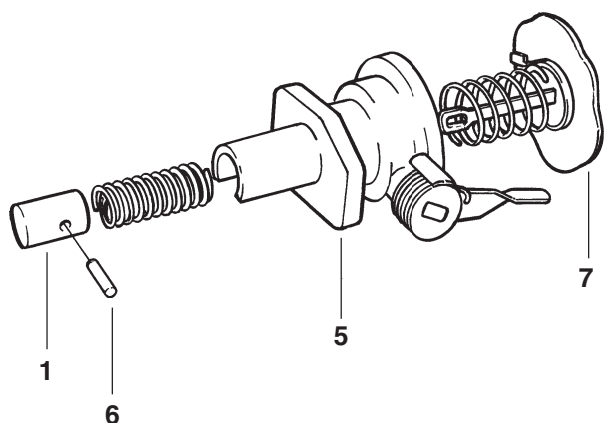
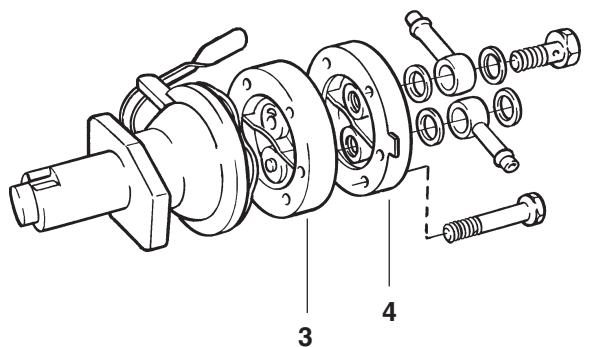

1. Piston
2. Strainer
3. Valve housing
4. Lid
5. Pump housing
6. Pin
7. Diaphragm

Assembling the feed pump

1. Assemble the piston (1), membrane (7) and springs in the pump housing (5). Press the piston and membrane together and press the pin (6) into the piston.
2. Turn the membrane and piston so that the pin (6) in the piston is not aligned with the groove in the pump housing.
3. Install the valve housing (3) and cover (4) according to the previously made marks. Tighten the screws.

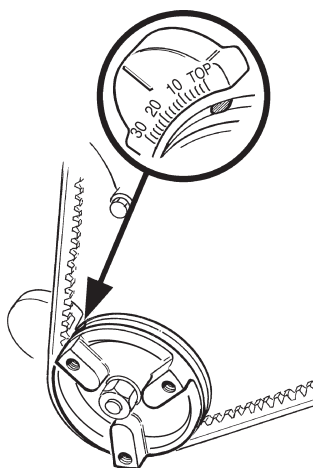
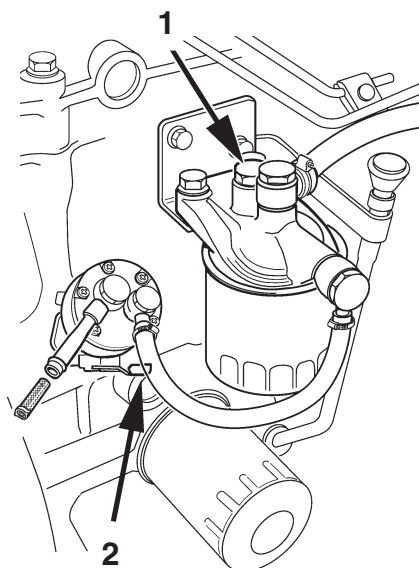

D2-55 A, B

Priming the fuel system

The fuel system must be primed after a filter change, if the fuel tank has been run dry and after a long-term stoppage.

D2-55A/B:

1. Open the priming screw (1) on the fuel filter. Avoid fuel spillage. Use i. e. rags on the priming point.
2. Pump fuel up with the hand pump (2) until fuel without air bubbles can be seen. Continue pumping and tighten the priming screw at the same time.

Note. If the pump works poorly, crank the engine so that the mark on the pulley is at "TOP" if it is still poor, crank the engine another revolution to "TOP".

3. Normally, additional priming is not required. Start the engine and check that no leakage occurs.
4. If the engine does not start after a short attempt, loosen the pressure pipes at the injectors a few turns. Hold the injection pump actuator arm in its max. position and crank the engine with the starter motor until fuel leaks from the pressure pipes. Tighten the pressure pipe nuts. Tightening torque, please refer to the "Technical Data" chapter.

The glow plugs are activated at the same time as the starter motor. You can save the batteries if the starter motor is only used for short periods when priming.

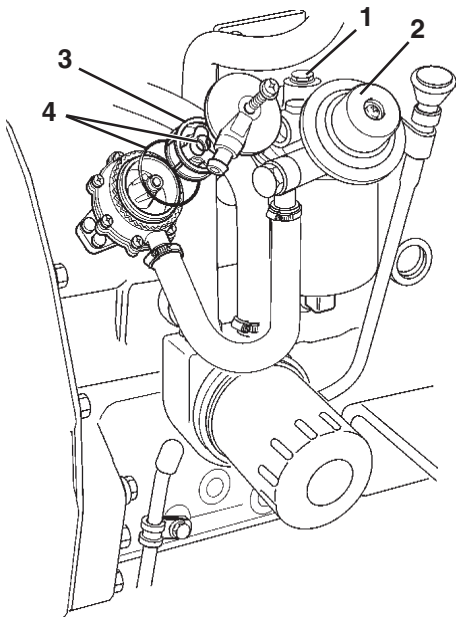

D2-55 C, D2-75 A

D2-55C and D2-75A:

1. Open the priming screw (1) on the fuel filter. Avoid fuel spillage. Use i. e. rags on the priming point.
2. Pump fuel up with the hand pump (2) until fuel without air bubbles can be seen. Continue pumping and tighten the priming screw at the same time.
The pump's inlet pipe contains a strainer (3) which normally does not need to be cleaned since the engine has a fuel pre-filter. If a pre-filter is not fitted, poor feed flow can be due to a blocked strainer.

Note. If either of the two O-rings (4) are damaged, they must be replaced.

3. Normally, additional priming is not required. Start the engine and check that no leakage occurs.
4. If the engine does not start after a short attempt, loosen the pressure pipes at the injectors a few turns. Hold the injection pump actuator arm in it's max. position and crank the engine with the starter motor until fuel leaks from the pressure pipes. Tighten the pressure pipe nuts. Tightening torque, please refer to the "Technical Data" chapter.

The glow plugs are activated at the same time as the starter motor. You can save the batteries if the starter motor is only used for short periods when priming.

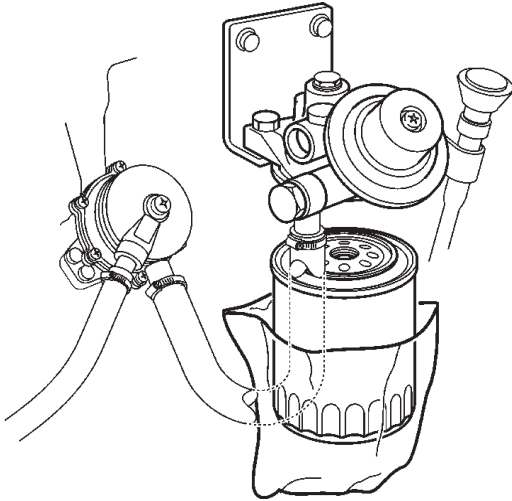

Fuel filter, replace

Clean the filter bracket. To prevent fuel spill, a plastic bag can be pulled over the filter. Unscrew the filter. Wipe a film of oil on the gasket of the new filter. Screw the filter on by hand until it touches the contact surface. Then tighten an extra half turn, **no more!** Prime the fuel system. **Deposit the old filter at a waste management facility.**

Start the engine and check that no leakage occurs.

⚠ WARNING! Working with, or going close to a running engine is a safety risk. Watch out for rotating components and hot surfaces.

Fuel pre-filter, draining and replacement of filter insert

Draining

The fuel pre-filter is extra equipment.

Put a suitable vessel underneath the filter. Drain off water and contaminants through the tap/plug in the bottom of the filter bowl.

⚠ IMPORTANT! Draining should be performed first a number of hours after stopping.

Replacing filter insert

Close the fuel stop cock on the tank. Put a suitable vessel underneath the filter.

Remove the filter bowl by undoing the screw (1). Empty and clean the filter bowl. Replace the insert and assemble the bowl. Open the stop cock. Prime the fuel system. **Deposit the old filter at a waste management facility.**

Start the engine and check that no leakage occurs.

⚠ WARNING! Working with, or going close to a running engine is a safety risk. Watch out for rotating components and hot surfaces.

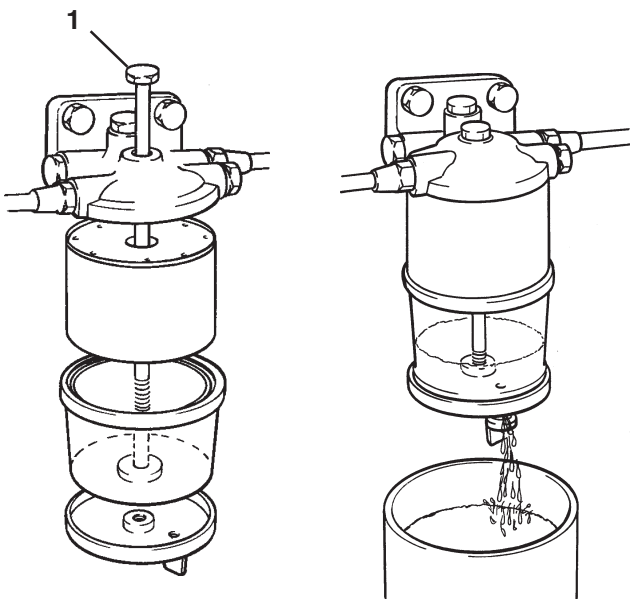

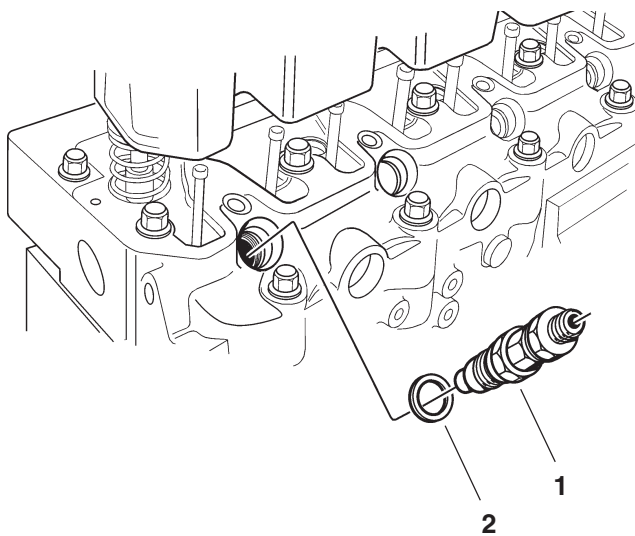

Injectors

Changing the injectors

1. Wash around the injectors.
2. Undo the delivery pipes at the injection pump and at the injectors. Lift the fuel delivery pipes away together.
3. Undo the nut at the top of each injector, use the nuts beneath the return fuel line as a counterhold so that the pipes are not bent. Lift the return fuel pipe away.
4. Unscrew the injectors (1). Use socket, L=80 mm. Remove the copper washers (2) beneath the injectors.
5. Fit a protective plug to the injector's pipe connection and over the injector nozzle if it is not to be installed immediately.
6. Install the new injector. Tightening torque, please refer to the "Technical Data" chapter.
7. Install the return fuel pipe, use the nut underneath the fuel return pipe to avoid kinking the pipe.
8. Install the pressure pipes. Check that they do not come out of alignment, and tighten the nuts. Tightening torque, please refer to the "Technical Data" chapter.
9. Start the engine and check that no leakage occurs.

Testing of injectors

Testing is done in an injector tester. During the test, the opening pressure and sealing are the most important things. The spray pattern is more difficult to evaluate and does not fully indicate the condition of the nozzle.

⚠ WARNING! Be careful when testing injectors, avoid getting the fuel jet from an injector on unprotected parts of your body. The spray has such great penetration power that it can penetrate the skin and cause blood poisoning.

Opening pressure

With the pressure gauge connected, press the injector tester lever down slowly until the injector opens and releases fuel. Read off the opening pressure at the opening instant.

If the value read does not coincide with the specified value, the setting must be changed. This is done with shims.

Note. The opening pressure increases or decreases by about 1 MPa with a change of shim thickness of 0.1 mm.

Checking injectors

Spray pattern

Special tools: 999 9772

1. Pump with injector tester 999 9772 and check the spray pattern. The fuel spray should be cone-shaped and aligned with the injector center line. Fuel drops shall not occur in the spray.
2. Check that the fuel spray has a circular cross-section.

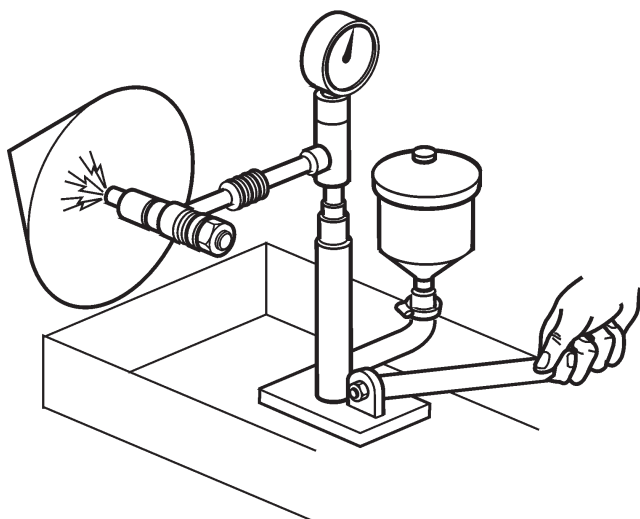

Sealing

When sealing is checked, investigate the fuel leakage which can occur between the injector nozzle seat and the tapered sealing surface in the injector sleeve.

1. Dry the injector nozzle so that it is dry.
2. Pump the pressure up to about 2 MPa below the opening pressure of the injector (please refer to Technical Data). Keep the pressure constant for about 10 sec. and check that no fuel drips out from the tip of the injector. Damp injectors can be approved.

Fit a protective plug to the injector's pipe connection and over the injector nozzle if it is not to be installed immediately.

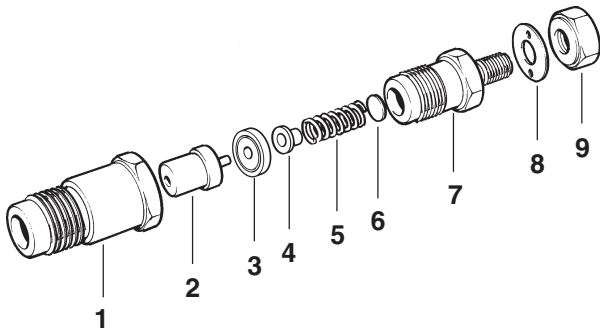

- | | |
|----------------------|---------------------|
| 1. Injector nut | 6. Adjustment shims |
| 2. Injectors | 7. Injector holder |
| 3. Joining piece | 8. Washer |
| 4. Compression screw | 9. Nut |
| 5. Spring | |

Overhauling injectors

1. Clean the injector externally.
2. Fix the injector (holder) in a vise. Unscrew the injector nut and disassemble the injector.

Note. Be careful that the injector nozzle does not fall out during disassembly.

3. Pull the injector nozzle out of the injector sleeve and put the components in cleaning petrol (gasoline).

Note. Make sure that the injector needles and injector sleeves which belong with each other, and fit together, are not mixed up if several injectors are cleaned at the same time. To avoid mixing up, the injectors should be put in an injector stand or in different compartments.

4. Check the injector nozzle thoroughly with a lamp magnifier or nozzle microscope. Also check the other components.

5. When installing a **new nozzle** it is important that the conserving oil is cleaned off the injector needle and sleeve before the injector is assembled (avoid skin contact with the needle's sliding surface).

Clean the components in chemically pure petrol (gasoline). Check that the needle slides in the sleeve with no tendency to bind.

6. Dip the injector components in pure Diesel or testing oil, and fit the components together. Use the original thickness of adjustment washer(s) to set the opening pressure.
7. Check the opening pressure, jet pattern and sealing in an injector tester.

Group 26 Cooling system

Fresh water system

The freshwater system is the engines internal cooling system that ensures that the engine operates at the correct temperature. It is a closed system and must therefore always be filled with a mixture of at least 40 % concentrated coolant and 60 % water, to offer protection from interior corrosion, cavitation and frost bursting.

We recommend that you use “**Volvo Penta Coolant, Ready Mixed**”, alternatively “**Volvo Penta Coolant**” (concentrated) mixed with **pure** water according to spec, see “Coolant. Mixing”. This grade of coolant is the only one that is developed for and approved by Volvo Penta.

The coolant should contain ethylene glycol of a good quality with a suitable chemical consistency that offers complete engine protection. Using an anti-corrosion mixture exclusively is not permitted in Volvo Penta’s engines. Never use water by itself as the coolant.

⚠ IMPORTANT! Coolant of a suitable chemical formula must be used all year round. This applies even if there is no risk for frost damage, so that the engine always has complete corrosion protection.

Future warranty claims on the engine and ancillaries may be rejected if an unsuitable coolant has been used or if the instructions concerning coolant mixing have not been adhered to.

NOTE! The anti-corrosive agents become less effective after a time, which means that the coolant must be replaced, see “Service schematic”. The cooling system should be flushed when the coolant is changed, please refer to “Cooling system. Cleaning”.

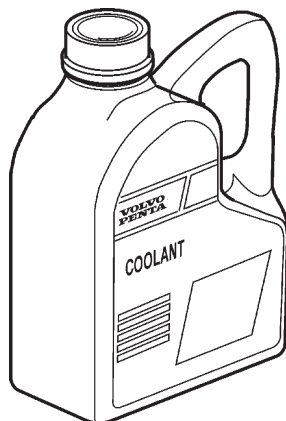

“**Volvo Penta Coolant**” is a concentrated coolant that is to be mixed with water. It has been prepared to work best with Volvo Penta engines and offers excellent protection against frost and cavitation damage, plus frost bursting.

“**Volvo Penta Coolant, Ready Mixed**” is a ready-mixed coolant, 40 % “Volvo Penta Coolant” and 60 % water. This concentration protects the engine against corrosion, cavitation damage and freezing conditions down to -28 °C.

Coolant. Mixing

⚠ WARNING! All glycol is dangerous to human health and ecologically damaging. Shall not be consumed!
Glycol is flammable.

⚠ IMPORTANT! Ethylene glycol should not be mixed with other types of glycol.

Mix:
40 % “Volvo Penta Coolant” (conc. coolant)
60 % water

This mixture protects against internal corrosion, cavitation and frost damage down to -28 °C. (Using 60 % glycol lowers the freezing point to -54 °C.) Never mix more than 60 % concentrate (Volvo Penta Coolant) in the cooling liquid, since this would give reduced cooling effect and increase the risk of overheating and frost damage.

⚠ IMPORTANT! Coolant shall be mixed with **pure** water, use **distilled - de-ionized water**. The water must fulfill the requirements specified by Volvo Penta, see “Water quality”.

⚠ IMPORTANT! It is extremely important that the correct concentration of coolant is added to the system. Mix in a separate clean vessel before filling the cooling system. Make sure that the liquids mix.

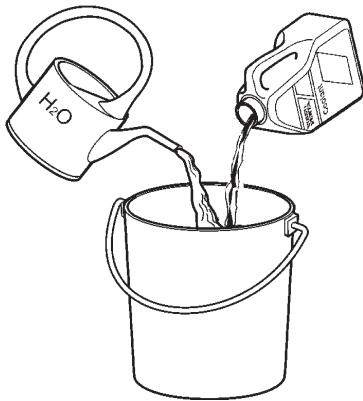

Water quality

ASTM D4985:

Total solid particles	< 340 ppm
Total hardness	< 9.5° dH
Chloride	< 40 ppm
Sulfate	< 100 ppm
pH value	5,5-9
Silica (acc. to ASTM D859)	< 20 mg SiO ₂ /l
Iron (acc. to ASTM D1068)	< 0.10 ppm
Manganese (acc. to ASTM D858)	< 0.05 ppm
Conductivity (acc. to ASTM D1125)	< 500 µS/cm
Organic content, COD _{Mn} (acc. ISO8467)	< 15 mg KMnO ₄ /l



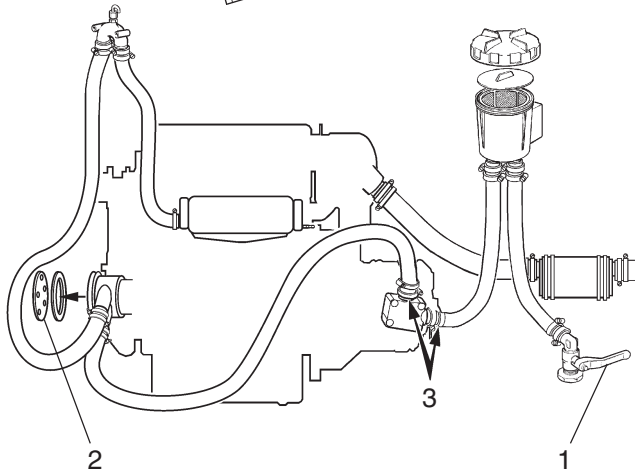
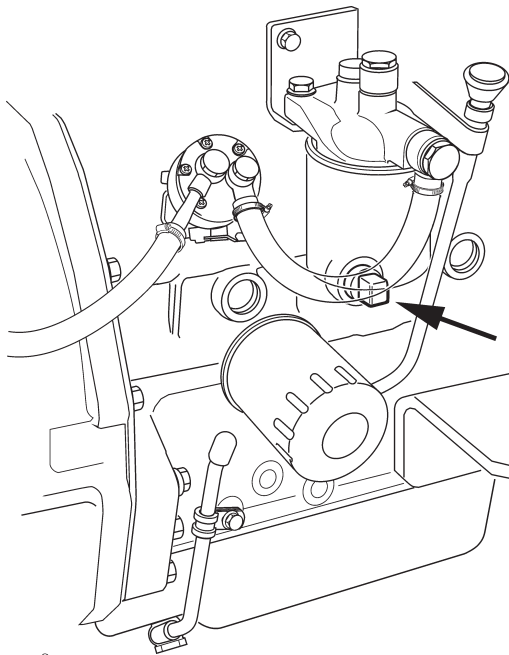

Draining coolant

Stop the engine before draining the cooling system.

Freshwater system

⚠ WARNING! Do not open the filler cap when the engine is hot, except in emergencies. Steam or hot fluid may spray out

1. Place a suitable collection vessel beneath the engine block drain plug (1) and at the heat exchanger drain tap.
2. Open the drain plug (1) and drain tap and drain all coolant.

NOTE! Deposit the old coolant at a recycling station for destruction.

Draining the seawater system

⚠ WARNING! Risk for flooding. Close the sea-cocks before starting work.

1. Close the sea cock (1) or the valve on the S-drive. Remove the cover (2) from the seawater pump and let the water run out.
2. Undo the hose (3) from the seawater pump and seawater filter at the reverser/drive and angle them downwards to let the water out.
3. Check if there are extra taps/plugs at the cooling and exhaust systems lowest points.
Check carefully that all the water runs out.
4. Tighten the hoses and the cover on the seawater pump. Bilge-pump the boat

⚠ WARNING! Check that there are no leaks in the seawater system.

Filling with coolant

Flush the cooling system clean before new coolant is added.

Close all drain points and fill up with coolant to the correct level.

The engine must be stationary when the cooling system is filled, and must not be started until the system is vented and completely filled. If a heating unit is connected to the engine cooling system, the heat control valve should be fully opened and the installation vented during filling.

Check the hoses and joints and rectify any leaks.

Fill the system slowly! Filling must not be done so fast that air locks are formed in the system. The air should be allowed to flow out through the filling opening. Check the coolant level after the engine has been run for about an hour. Top up with coolant as necessary.

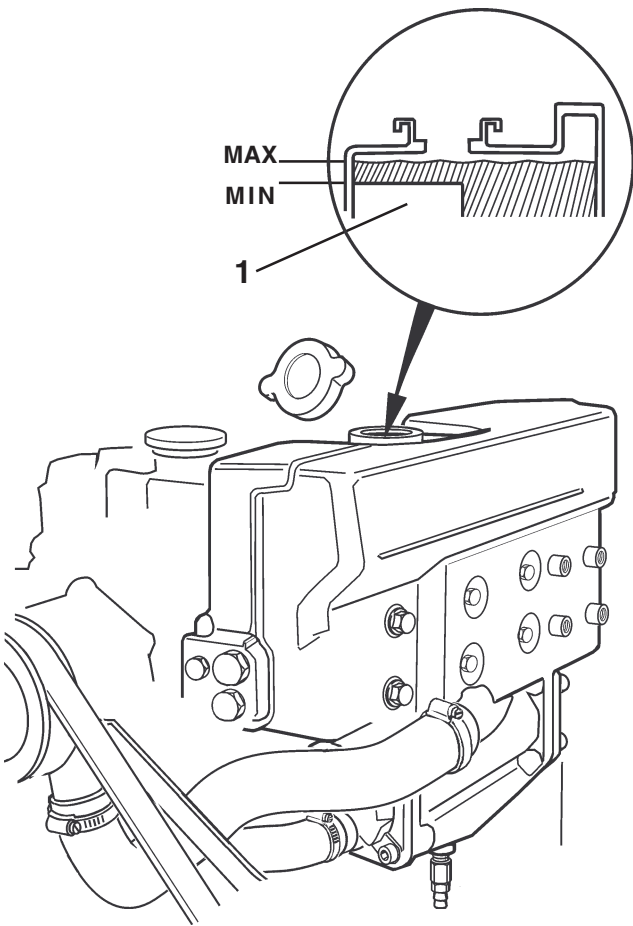

Checking the coolant level

⚠ WARNING! Do not open the filler cap when the engine is hot, except in emergencies. Steam or hot fluid may spray out.

Turn the filler cap to the first stop and allow any excess pressure to hiss out before removing the cap completely. Top the coolant up as necessary. The level should be between the filler opening and the lower edge of the level marker (1). Fit the filler cap.

If a separate expansion tank is fitted (extra equipment), the coolant level shall be between the MIN and MAX marks.

Coolant temperature too low

Low coolant temperature can be caused by:

- Faulty thermostat.
- Faulty temperature sensor or instrument.
- Engine running with low load.

Coolant temperature too high

High coolant temperature (warning lamp lights up) can be caused by:

- Blocked sea water inlet or sea water filter
- Defective impeller in the sea water pump.
- Coolant level Too low, air in the fresh water system.
- Slipping or broken drive belt for circulation pump.
- Faulty thermostat, temperature sensor or instrument.
- Blocked cooling system.
- Incorrectly set injection timing on the injection pump.
- Filler cap gasket does not seal.

Coolant losses

There are two types of coolant losses:

- Coolant losses during operation.
- Coolant losses after stopping a hot engine.

Coolant losses during operation can be due to a leaking cooling system or air or combustion gases being forced into the cooling system.

Checking the pressure valve in the filler cap

Special tools: 999 6662

1. Drain some of the coolant and connect the pressure testing device 99 6662 to a nipple or other plugged hole in the cooling system.
2. Extend the drain hose from the filler pipe with a hose which ends up in a water - filled vessel.
3. Increase the pressure and read the pressure gauge when the valve opens (water bubbles into the vessel with the drain hose). The valve should open at 0.09 MPa.
4. Remove the test equipment. Install the plug and fill the engine up with coolant.

Cleaning heat exchanger

Clean the heat exchanger insert at any sign of blockage (slowly increasing coolant temperature).

NOTE! First check/clean the seawater filter. Also check the seawater pump impeller wheel and the seawater intake.

⚠ IMPORTANT! Close the sea cocks before working on the cooling system.

1. Drain the water from the seawater and freshwater systems.
2. Disassemble the exhaust manifold together with the heat exchanger.
3. Undo the screws and covers at the front and rear of the heat exchanger. Pull out the insert.
4. Flush and clean the insert, both internally and externally. Also clean the housing.

If there are loose deposits in the insert, cleaning can be performed by passing a suitable steel rod through the tubes in the opposite direction to the water flow.

NOTE! Check that the rod does not damage the tubes.

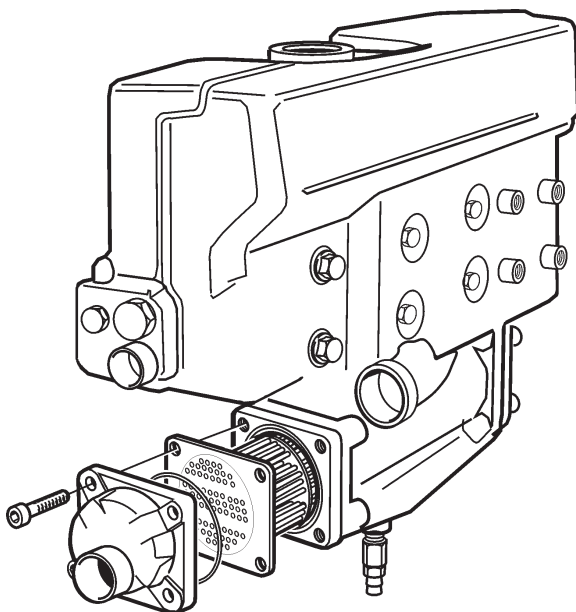

5. Install the insert in the heat exchanger.

NOTE! Be careful to install the insert in the correct position.

Make sure the hole in the insert aligns with the hole in the housing and that the venting hole is upwards. The insert is marked with "UP".

6. Install the covers on the front and rear ends of the heat exchanger. Connect the hose from the sea-water pump and tighten the clamp.
7. Assemble the exhaust manifold together with the heat exchanger.
8. Fill the engine with coolant.
9. Open the sea cocks or valve on the S-drive and start the engine. Check that no leakage occurs.

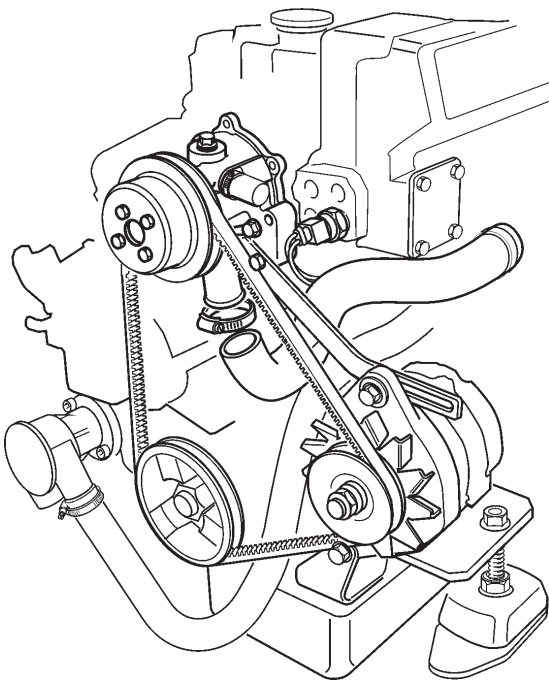

Replacing the circulation pump

Removal

1. Drain the coolant from the engine (freshwater system).
2. Undo the alternator and remove the drive belt. Remove the alternator tensioner.
3. Remove the rubber hoses to and from the pump.
4. Remove the electric connection from the temperature monitor.
5. Remove the pump's fixing bolts and lift out the pump.

Fitting

1. Clean the contact surfaces on the pump and cylinder block.
2. Install the coolant pump with a new gasket.
3. Fit the tensioner to the alternator.
4. Install the rubber hoses to and from the pump. Tighten the hose clamps.
5. Install the drive belts. It should be possible to depress the belt approx. 10 mm between the pulleys.
6. Reconnect the temperature monitor.
7. Fill the engine with coolant. Start the engine and check carefully that no leakage occurs.

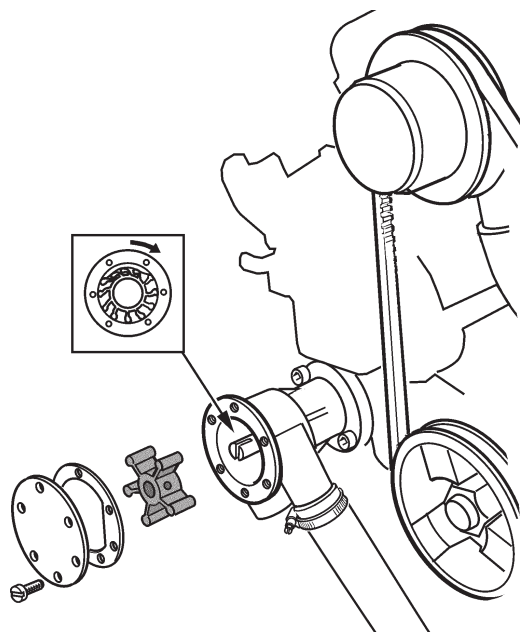

Replacing impeller in seawater pump

Close the sea cock or the valve on the S-drive before working on the cooling system.

1. Remove the end cover of the pump and drain the water from the seawater system.
2. Pull and twist out the impeller with water-pump piers.
3. Clean inside the housing. Grease the pump housing and the inside of the cover with a little water-resistant grease **intended for rubber**.
4. Push in the new impeller with a twisting motion (clockwise). Install the sealing washer at the outer end of the impeller center.
5. Install the cover with a new gasket.
6. Open the sea cock, or tap on the S-drive. Start the engine and check carefully that no leakage occurs.

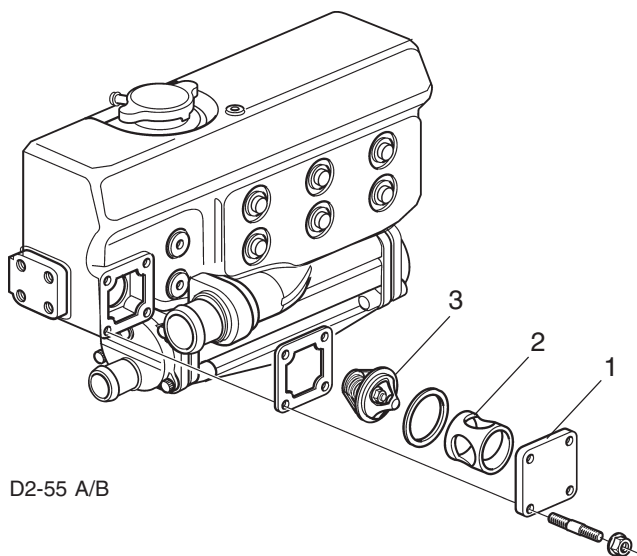

D2-55 A/B

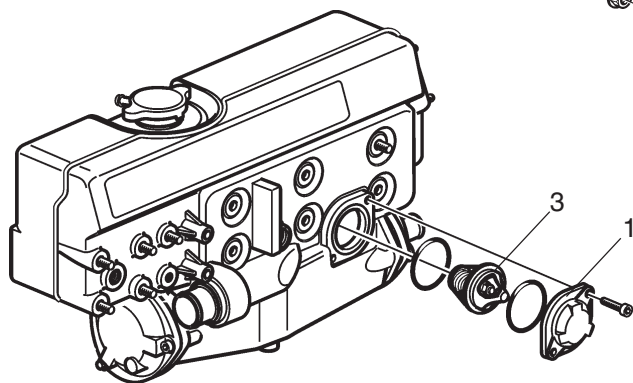

D2-55 C & D2-75

Thermostat

Replacing the thermostat

1. Turn the main switch off. Drain the water from the freshwater system.
2. Remove the cover (1), the spacer (2) and lift out the thermostat (3). Remove the rubber ring.

Checking the thermostat

1. Check that the thermostat closes completely.
2. Heat up water in a container to 75 °C .
3. Lower the thermostat into the water. Check that the thermostat is still closed after 3-5 minutes.
4. Raise the temperature to boiling point (100 °C). Check that the thermostat has opened at least 8 mm after 3-5 minutes. Replace the thermostat if it does not fulfill the requirements.

NOTE! If the thermostat does not close completely, the engine will run too cold.

Group 30 Electrical system

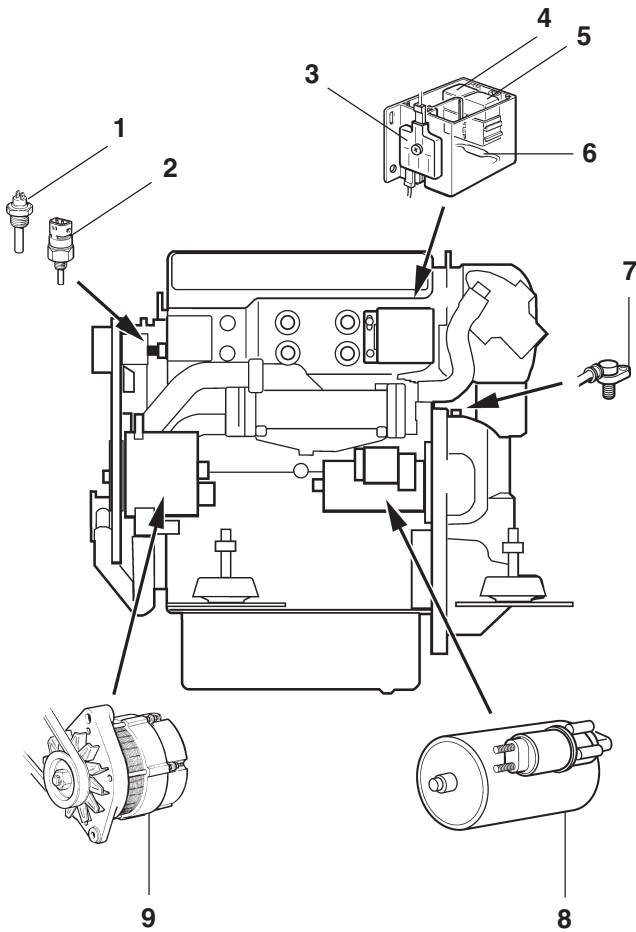

General

The engine is fitted with an AC alternator. The system voltage is 12V and the electrical system is single-pole.

The electrical system can include, as extra equipment, sensors for monitoring the engine's coolant temperature and oil pressure.

The electrical system is shown in two ways. The wiring diagram shows wire runs, cable cross section and color.

Fuses

The engine is equipped with a fuse block with four fuses (15A). One fuse safeguards the electrical system and blows if overloaded, the others are spares.

If a fuse blows, the electrical system can be reconnected by moving the cable to the next fuse/connector. Always first investigate the reason for the overload.

Relays

The starting and glowplug functions are each controlled by a switching relay. These relays are identical and are thus mutually interchangeable.

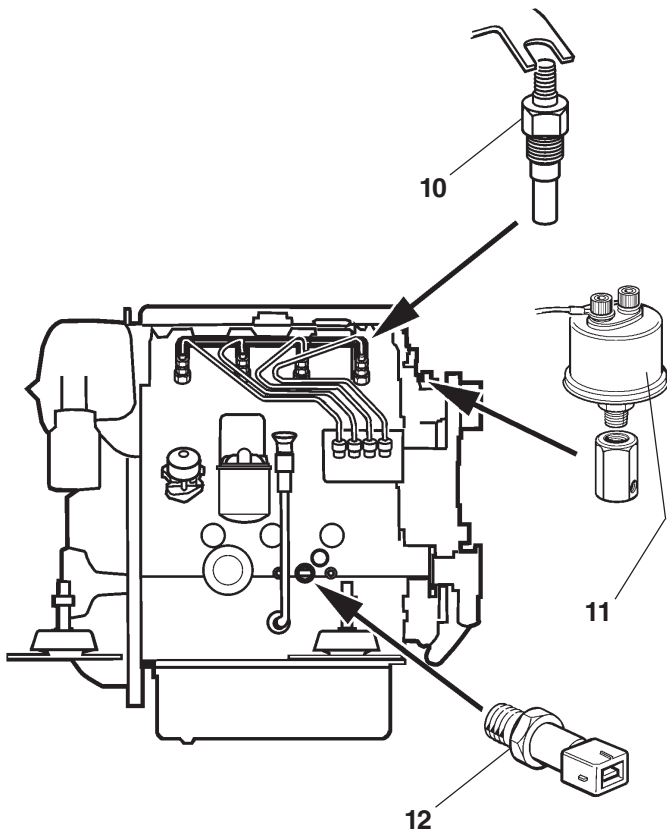

1. Coolant temperature sensor (extra equipment)
2. Coolant temperature monitor
3. Fuses
4. Starter relay
5. Glowplug relay
6. Charge sensing resistor
7. Engine speed sensor
8. Starter motor
9. Alternator
10. Glowplug , 4 pcs.
11. Oil pressure sensor (extra equipment)
12. Oil pressure monitor

Alternator

Voltage regulator with sensor system

The voltage regulator on the standard alternator (14V/60A) is equipped with a sensor system.

The sensor system compares the charge voltage between the alternator terminals, B+ and B-, with the voltage across the battery positive and negative terminals. The voltage regulator then compensates for any voltage drop in the cables between the alternator and the batteries, by increasing the charge voltage supplied by the alternator as necessary.

When delivered from Volvo Penta, the sensor system is not activated. The connection has probably been done during engine installation, however.

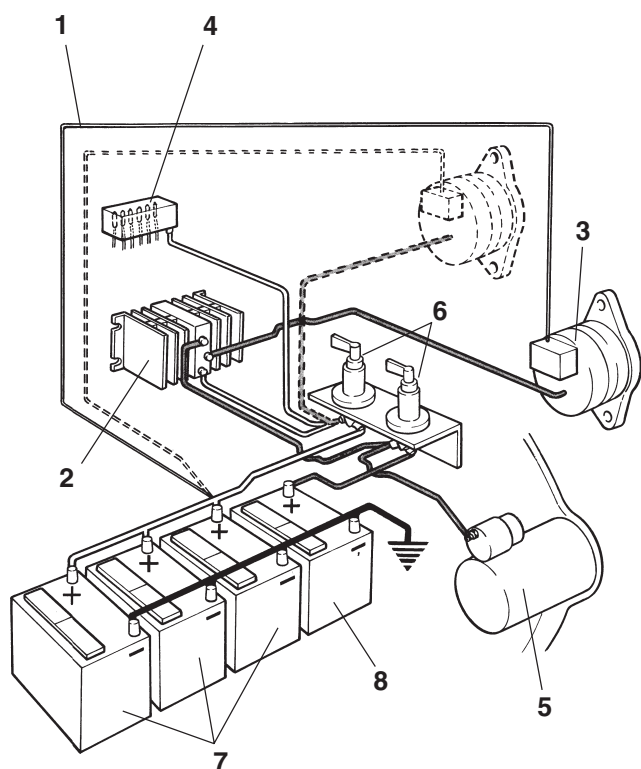

1. Sensor wire (yellow, 1.5 mm²)
2. Charge splitter (extra equip.)
3. Alternator
4. Fuse panel (extra equip.)
5. Starter motor
6. Main switch
7. Auxiliary batteries (extra equip.)
8. Starting battery (engine)

Connecting the sensor system

⚠ IMPORTANT! Stop the engine and disconnect power with the main switch before working on the electrical system.

1. Release the yellow sensor wire from connection B+ on the alternator.
2. Splice the wire (yellow, 1.5 mm²) and run it to the batteries. Connect the wire to the batteries' positive pole (+).

Charge splitter

As extra equipment, the engine's standard alternator can be fitted with a charge splitter. Two independent battery circuits can in this way, be charged at the same time. The charge splitter separates the two circuits from each other so that the engine's starting battery is kept fully charged even if the "accessory batteries" are weak or even totally discharged.

Important information – electrical system

 **IMPORTANT!** Stop the engine and turn off the power at the main switch(es) before carrying out work on the electrical system.

Battery main switch

Never break the circuit between the alternator and the battery while the engine is running. The main switch (es) shall, therefore never be switched off before the engine has stopped. If the circuit is disconnected while running, the voltage regulator can be destroyed and the alternator can be seriously damaged.

The charging circuits must never be re-connected with the engine running, for the same reason. For simultaneous charging of two independent battery circuits, a Volvo Penta charge splitter can be fitted to the standard alternator (accessory).

Batteries

Never mix up the battery's positive and negative terminals when fitting batteries. Incorrect installation can result in serious damage to the electrical equipment. Refer to the wiring diagram. The battery poles shall be kept well cleaned and the cable shoes shall always be tightened and well greased, to avoid power loss.

Fast charging of the batteries should be avoided. If fast charging must be used, the battery cables shall always be disconnected first.

NOTE! Follow the appropriate safety regulations when charging batteries. During charging, unscrew the cell plugs but leave them in the plug holes. Ventilate well, especially if the batteries are charged in an enclosed space. Always switch off the charging current **before** the charging clips are removed.

 **WARNING!** Never expose the battery area to naked flame or electrical sparks. Never smoke close to the batteries. The batteries generate hydrogen gas when charged, which forms an explosive gas when mixed with air. This gas is easily ignited and highly explosive.

Always use protective goggles when charging and handling the batteries.

Battery electrolyte contains sulfuric acid which is highly corrosive. Should the battery electrolyte come into contact with unprotected skin wash off immediately using plenty of water and soap. If you get battery acid in your eyes, flush at once with a lot of water, and get medical assistance at once.

Electrical wiring

Never make holes in the cables insulation to perform measurements with needles. In a corrosive atmosphere such as a boat, it only takes 2 years for a small cable with a needle hole to oxidize off.

If it is absolutely necessary to make a hole in the insulation, this must be repaired in a suitable way after testing.

Connection of extra equipment

All extra equipment shall be connected to a separate connection box and correctly fused. Extra power take-offs directly from the instrument panel should be avoided. The permitted extra take off is however **total-ly max. 5A** (applies to all instrument panels together).

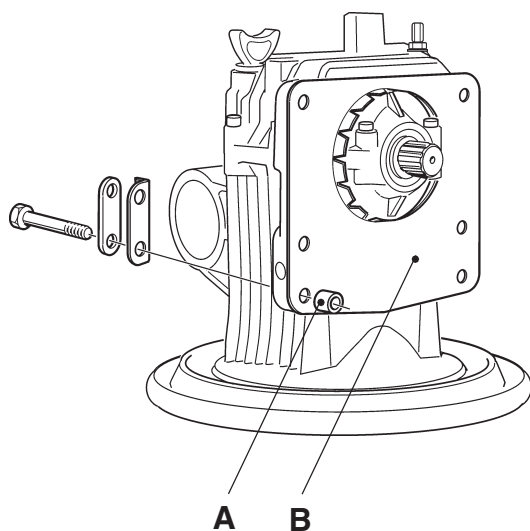

Galvanic corrosion

The S-drive is electrically isolated from the engine and shall never be used as a grounding plane.

The S-drive has insulation (B) placed between the adapter plate and the upper gear housing. An isolation bush (A) shall be installed on one of the lower bolts.



IMPORTANT! The S-drive shall never be used as a grounding plane or be electrically connected with any other equipment, i.e. radio, navigation equipment, rudder, bathing steps, etc.



Electric welding

Remove the positive and negative cables from the batteries. Then disconnect all cables connected to the alternator.

Always connect the welder earth clamp to the component to be welded, and as close as possible to the weld site. The clamp must never be connected to the engine or in such a way that current can pass through a bearing.



WARNING! After welding is finished, the wires to the alternator must be reconnected **before** the battery cables are reconnected.

Repair Instructions

Fault finding glow plugs

Special tools: 9812519

1. Remove both battery cables.
2. Remove the power rail between the glow plugs.
3. Measure the resistance of each glow plug to the engine block with an ohmmeter. The resistance shall be $1.6 \pm 0.16 \Omega$. If the instrument shows 0 the glow plug is short-circuit and must be replaced.

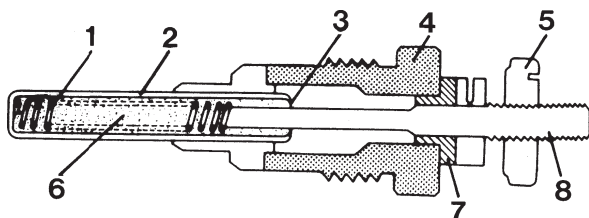

- | | |
|--------------|--------------------|
| 1. Glow wire | 5. Nut |
| 2. Jacket | 6. Magnesium oxide |
| 3. Seal | 7. Insulation |
| 4. Socket | 8. Core |

Replacing glow plugs

1. Remove both battery cables.
2. Clean around the glow plugs.
3. Undo the connection from the power rail to the glow plug.
4. Remove the power rail and unscrew the glow plug.
5. Install the new glow plug. Tightening torque, please refer to the "Technical Data" chapter.
6. Reinstall the power rail and connect the glow plug. Install the battery cables.

Fault tracing the charging system

The engines are equipped with a rectified three-phase delta-coupled alternator of 14V/60A (840W).

The alternator's designation can be found on a plate on the rear of the alternator.

Checking and overhauling

Before disassembly of the alternator is started, fault tracing of the battery circuit should be performed in order to eliminate other possible faults. Testing should be performed with the alternator "hot". Run the engine at 2000 r.p.m. for about 3 minutes before measuring.

⚠ WARNING! The alternators, voltage regulators and battery circuit connections may not be disconnected or be disconnected with the engine running. Check carefully that the measuring instrument is set to voltage measurement ("V") to avoid short circuiting between the alternators connections.



WARNING! Be extremely careful so that the measurement cables, clothes or similar come into contact with the drive belt or pulleys on the engine or alternator when the engine is running.

Check the tension of the alternator belt and the belt condition. Replace the belt if it is cracked, worn or oily. Adjust the belt tension as required. It should be possible to depress the belt approx. 10 mm between the pulleys.

Fault tracing the battery circuit

Special tools: 9812519

Note that other instruments may use different symbols for the set measurement function.

Current loss check

1. Wash the battery with lukewarm water and dry off. Remove the battery cables and clean the poles.
2. Reconnect the positive pole (+) again.
3. Turn off the keyswitch or disconnect power to the instrument panel and all other consumers connected to the starting battery.
4. Set the multimeter for DC current measurement (+20A). Connect the multimeter between the battery's negative pole (-) and the negative cable. The current loss may not exceed 0.1 A with the keyswitch or instrument panel disconnected.

If the current loss is greater than 0.1 A:

Check that no short circuits or leakage occurs at any of the connection points. Leakage can occur through dirty or salt-encrusted electrical components.

Clean and check all connection points.

If the current loss is less than 0.1 A:

Check the charge status of the battery.

}

Checking charge status

Check the charge status with an acid densitometer. Measure the acid density of all cells at +25 °C. Measurement shall not be done immediately after charging or filling with battery water.

The acid density of a fully charged battery at +25 °C shall be 1.28 g/cm³. Charge the battery if the acid density is less than 1.24 g/cm³ (approx. 75 % charged). Charge at 5-6A for 10 hr.



WARNING! The battery generates hydrogen gas which is easily ignited and highly explosive. Never expose the battery to naked flame or electrical sparks. Ventilate the battery area well, especially after charging.

Check 2hr. after charging

If the acid density of the cells is uneven, a cell is probably short circuit. Replace the battery if the difference between cells is 0.04 g/cm³ or more (i.e. 1.28-1.24 g/cm³).

If the acid density between cells is even, then the battery is not fully charged.

Sulfated battery. A minor case of sulfating can be broken down by an additional 10 hours charging. Replace the battery if this does not help.

Load testing the battery

The battery acid density may not be less than 1.21 g/cm³.

1. Fix a voltmeter across the battery poles
2. Activate the stop function and run the starter motor for about 10 seconds with the glow plugs activated and read off the start voltage. It should not be less than 9.5 V.
3. Check if any of the cells bubble when the starter motor is operated (short-circuit cell).
4. If the voltage is less than 9.5 V or if any of the cells bubble:

Replace the battery and try again.

If the voltage is 9.5 V or higher:

The battery is OK. Check the charging voltage (see next paragraph).

Checking the battery leads

Set the multimeter to voltage test and connect the multimeter between the battery's positive and negative poles. Run the engine at 2000 r.p.m. Read off and note the voltage across the poles.

The alternator delivers approx. 14.0 V:

Perform the test as follows:

1. Connect the multimeter between the alternator connections B+ and B-.
2. Run the engine at 2000 r.p.m. The alternator shall deliver 14.0-14.4 V. The total voltage drop shall not exceed 0.4 V.

Voltage drop less than 0.2 V:

Battery leads OK.

Voltage drop more than 0.3 V:

Perform a check of the battery leads.

The alternator supplies more than 14.4 V:

See sections "Checking and Fault Tracing the Alternator", and "Checking the Regulator".

Checking the positive (+) battery lead

1. Connect the multimeter between the alternator connection B+ and the battery positive pole.
2. Run the engine at 2000 r.p.m. The voltage drop shall not exceed 0.2 V. If the voltage drop exceeds this, the battery lead/connection must be remedied according to "Actions" below.

Then perform the test for "Check of the negative battery lead".

Checking negative (-) battery lead

1. Connect the multimeter between the alternator connections B- and battery negative pole (-).
2. Run the engine at 2000 r.p.m. The voltage drop shall not exceed 0.2 V. If the voltage drop exceeds this, the battery lead/connection must be remedied according to "Actions".

Actions



WARNING! Disconnect power and remove both battery cables before working on the charging circuit.

If the voltage drop in any of the tests above exceeded 0.2 V, the battery leads/connections must be removed and cleaned from oxide etc. They spray the connections with a moisture dispersent contact oil and tighten the connections once more.

Treat the connections at the battery, main switch, starter motor, alternator, glow plug relay and glow plugs.

Alternator

Checking and fault tracing the alternator

1. Remove the alternator's electrical connections. Remove the alternator belt. Remove the alternator.
2. Undo the voltage regulator's connection at the alternator connection B+. Unplug the blade connectors at connections B+ and D+. Remove the protective cover from the W connection.
3. Lever the plastic cover fixing ears from side to side off the alternator. Undo the regulator's connection cables to the diode bridge. Use flat pliers or poke the cable shoes out with a screwdriver. Do not pull on the cables!

Replacing alternator brushes

Unscrew the voltage regulator. Unscrew the brush holder. Check the length of the brushes. Replace the brushes if they are 5 mm or shorter. The brush and holder are replaced as a unit. Unsolder the connection cables and solder on the new with acid-free solder.

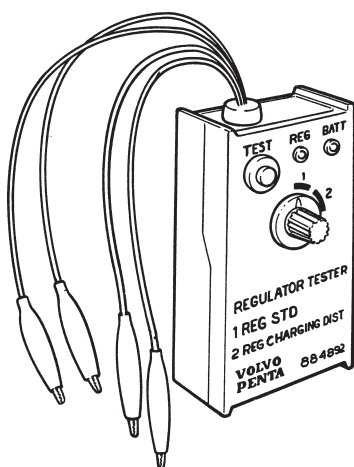

Checking the regulator

Special tools: 884 892

Before performing the test, check that the regulator tester battery has the correct voltage. Press the "Test" button and check that the green lamp ("Batt.") lights. Replace batteries (2 pcs alkaline, 9 V) if the lamp does not light. The batteries are in a compartment on the underside of the instrument.

Connect the tester's gray wire to the brush.

Connect the tester's brown wire to the regulator's yellow and brown wires, which are to be held together for the test.

Connect the tester's black wire to the regulator's black wire.

Press the "Test" button and at the same time turn the rheostat from "0" to "1".

Regulator OK

The red and green lamps shall light from "0". As the rheostat is turned, the red lamp should go out at "1".

Faulty regulator

Replace the regulator if the red lamp lights through the whole travel of the rheostat or if it does not light at all.

Note. Point "2" on the tester is not used for this type of regulator.

Checking the rotor winding

Once the regulator and brushes have been removed, it is possible to measure the resistance of the rotor windings.

Set the measurement instrument to position Ω . Make sure the probes have good contact with the slip rings. The rotor resistance should be 3.0-5.0 Ω .

Also check for grounding faults by measuring between the slip rings and ground.

Removing the diode bridge

In order to check the diode bridge and stator windings, the diode bridge should be removed.

Unsolder the three stator windings. Do not use too much heat as this can damage the diodes. Undo the nuts (note how the nuts and washers are fitted).

Checking the diode bridge

Set the multimeter to position "Diode test". Be very sure that you have good probe contact for all measurements.

Checking B+ diodes

1. Connect the multimeters positive probe to one of the stator winding's connections (1-2-3). Then connect the instruments negative probe to the diode plate B+ connection. Read off the instrument. A normal value should be between 450 and 650 mV which is the voltage drop across the diode. Any other value indicates a faulty diode.
2. Check the other B+ diodes by moving the positive probe to the other connections (1-2-3).
3. Then check the B+ diodes in the opposite direction by reversing the positive and negative probes. Perform the same measurements as above. The instrument should show a one "1" with these measurements (furthest to the left). Any other value on the instrument indicates a faulty diode.

Checking B- diodes

1. Connect the instruments positive probe to the diode plate B- connection and the instruments negative probe to one of the stator windings connections (1-2-3).
2. Read off the instrument as previously. A normal value should be between 450 and 650 mV. Any other value indicates a faulty diode.
3. Then check the B- diodes in the opposite direction by reversing the positive and negative probes. Perform the same measurements as above. The instrument should show a one "1" with these measurements (furthest to the left). Any other value on the instrument indicates a faulty diode. If any of the diodes are faulty, the whole diode plate must be replaced.

Checking D+ diodes

The diode plate's three magnetization diodes are checked in the same way as above.

1. Connect the instrument's positive probe to each stator winding connection (1-2-3) and the negative probe to D+. The voltage drop for each diode should be between 450 and 650 mV.
2. Then check the D+ diodes in the opposite direction by reversing the positive and negative probes. Perform the same measurements as above. The instrument should show a one "1" with these measurements (furthest to the left). Any other value on the instrument indicates a faulty diode. If any of the diodes are faulty, the whole diode plate must be replaced.

Checking the stator windings

Once the diode bridge is removed, the stator windings can be measured by setting the multimeter to “buzzer position”.

Measure the resistance of each winding.

NOTE! First check the internal resistance of the measurement wires. When measurement of the stator windings is performed, the internal resistance of the measurement wires (i.e. 0.10Ω) must be subtracted from the value displayed.

Measure between all winding connections (three measurements). The resistance be 0.10Ω .

Also measure to the alternator body by connecting the instrument in position Ω . And then measure from each winding to the body. The instrument should show a one “1” with these measurements (which means infinity).

If the instrument shows any other value, the stator winding is faulty. If any of the stator windings are faulty, the complete stator ring must be replaced.

Starter motor

General

The starter motor is a DC series motor. The starter pinion is operated by a control solenoid and can be slid axially on the rotor.

The starter motor is fitted with a reduction gear, which provides a higher torque.

Removing the starter motor

1. Remove both battery cables.
2. Undo the electrical connections from the starter motor.
3. Remove the starter motors fixing bolts and lift off the starter motor.

Disassembling the starter motor

1. Clean the starter motor externally.
2. Remove the solenoid.

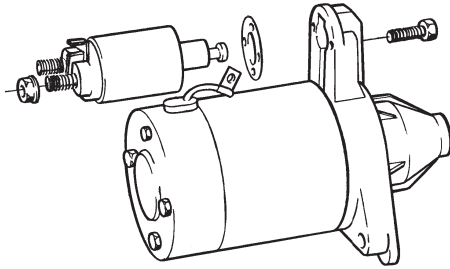

3. Remove the protective cover from the rear bearing casing. Remove the locking ring and where fitted, the shim(s).
4. Remove the rear bearing casing.
5. Remove the brush plate. Remove the stator housing from the gear housing.

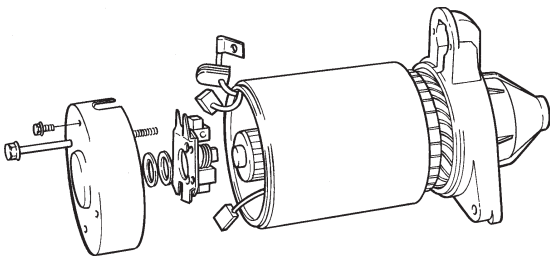

6. Remove the lever arm that is fitted in the gear housing and the rotor.

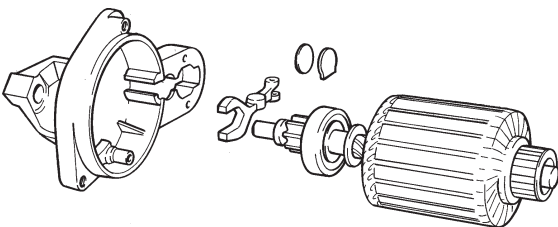

7. Remove the starter gear that is fitted in the gear housing. First remove the locking ring by striking the contact ring with a suitable sleeve.

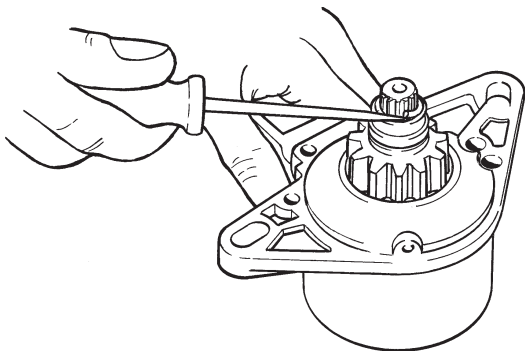

Inspecting the starter motor

Fault tracing the starter motor should be left to an authorized electrical workshop which has the necessary test equipment.

1. Test the rotor with regard to winding breakdown and open circuits with the appropriate test equipment.
2. Check that the brushes' contact surface on the commutator is even and free from dirt and oil. If the commutator is worn or burnt it can be ground with emery paper no. 500 or 600.

Measure the commutator with a dial gauge. Max. permitted runout is 0.05 mm.

3. Check that the insulation is at least 0.2 mm below the commutator surface. Correct as necessary.
4. Check the straightness of the rotor. Set the rotor up between centers and measure the runout of the rotor frame with a dial gauge. Max. runout 0.08 mm. The runout is half of the indicated value.
5. Check the starter gear teeth. Replace damaged gears. Also check the ring gear if the starter gear is damaged.

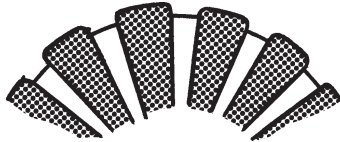

Field windings

Check with the test instrument that there is no open circuit in the windings. Faulty field windings must be replaced.

Assembling the stator

Assembly is the reverse of disassembly.

Connect + and - from a 12 V battery to the terminals on the solenoid and check that the starter gear is thrown forward to the gear stop.

Installing the starter motor

1. Place the starter motor in position on the flywheel housing and tighten it.
2. Connect the electrical wiring to the starter motor. See wiring diagram for starter motor.
3. Connect the battery cables.

Electrical components

Relay box with fuses

The engine is equipped with a fuse block with four fuses (15A). One fuse safeguards the electrical system and blows if overloaded, the others are spares.

If a fuse blows, the electrical system can be reconnected by moving the cable to the next fuse/connector. Always first investigate the reason for the overload.

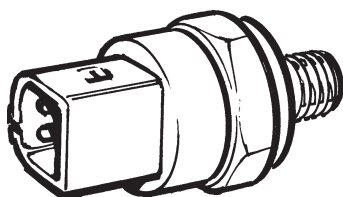
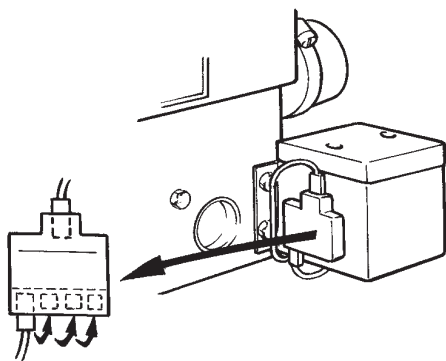

Monitors

Lube oil pressure monitor - alarm

Contact type: Normally open. The contacts close if the lube oil pressure in the engine drops below 0.3 ± 0.15 bar.

Check of the closing point is done with **falling** pressure.

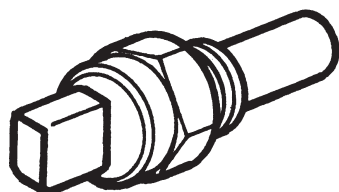

Coolant temperature monitor - alarm

Contact type: Normally open. The contacts close if the coolant temperature rises above $95 \text{ }^\circ\text{C} \pm 3 \text{ }^\circ\text{C}$.

Check of the closing point is done with **rising** temperature.

Sensor

Note. Sensors are only supplied together with the “De Luxe” instrument panel.

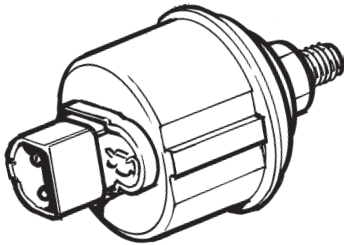

Lubrication oil pressure sensor

Resistance checking, measured with falling pressure and instrument connected. Measured with ohmmeter class 1 at + 20°C.

Pressure

0 bar: $10 + 3 / -5 \Omega$

2 bar: $52 \pm 4 \Omega$

4 bar: $88 \pm 4 \Omega$

6 bar: $124 \pm 5 \Omega$

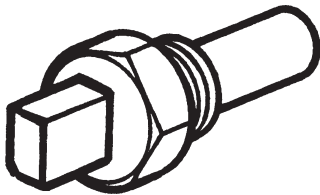

Coolant temperature sensor

Resistance checking, measured with sensor immersed in circulating liquid down to the hexagonal screw for 3 minutes with power connected:

Temp. 60 °C: $134,0 \pm 13,5 \Omega (\pm 4 \text{ } ^\circ\text{C})$

90 °C: $51,2 \pm 4,3 \Omega (\pm 4 \text{ } ^\circ\text{C})$

100 °C: $38,5 \pm 3,0 \Omega (\pm 4 \text{ } ^\circ\text{C})$

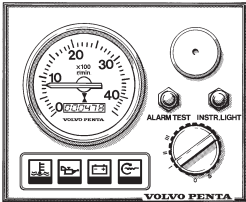

Instrument panel, alternative "B" *

* (with starter switch)

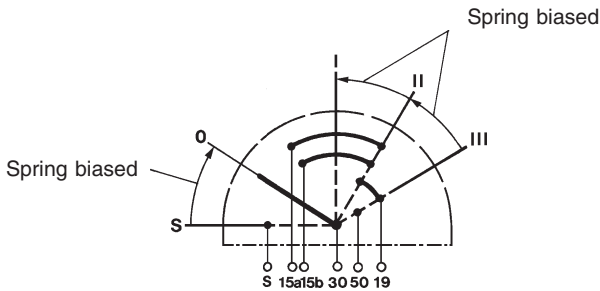
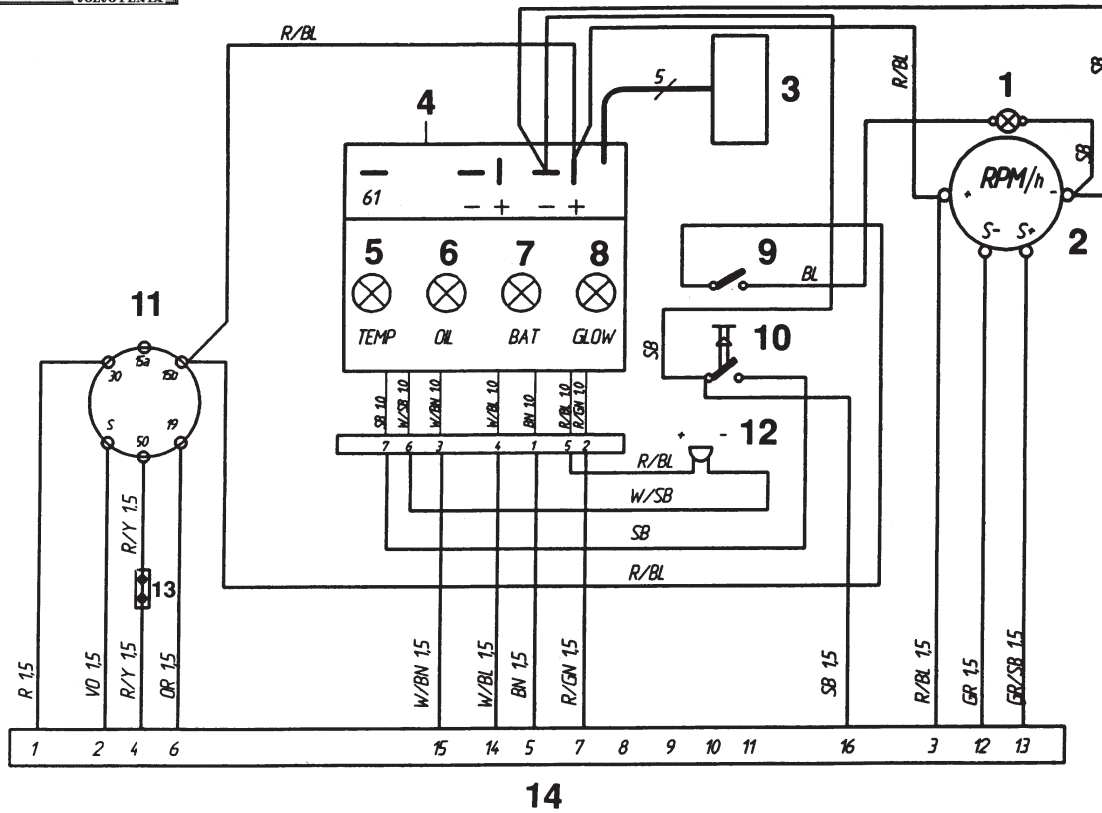

Cable colors

- BL = Blue
- BN = Brown
- GN = Green
- GR = Gray
- OR = Orange
- R = Red
- SB = Black
- VO = Violet
- W = White
- Y = Yellow

1. Instrument illumination
2. Tachometere with built-in running hours timer (extra equip.). Or blanking plug
3. Connector for connecting extra warning display (optional equipment)
4. Electronic unit (alarm)
5. Warning lamp, coolant temperature
6. Warning lamp, oil pressure
7. Charge warning lamp
8. Indication lamp, glow plugs
9. Switch, instrument lighting
10. Switch - Alarm test/Acknowledge
11. Key switch
12. Alarm
13. Connector for connecting neutral position switch (extra equip.)
14. 16-pin connection

Cable cross section in mm² is given after the color code on the wiring diagram.

Cross section not given = 1.0 mm²

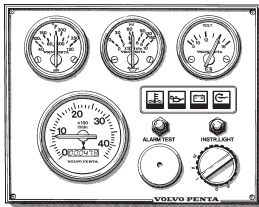

Instrument panel, alternative "C"

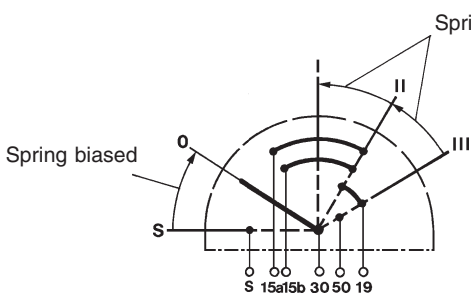
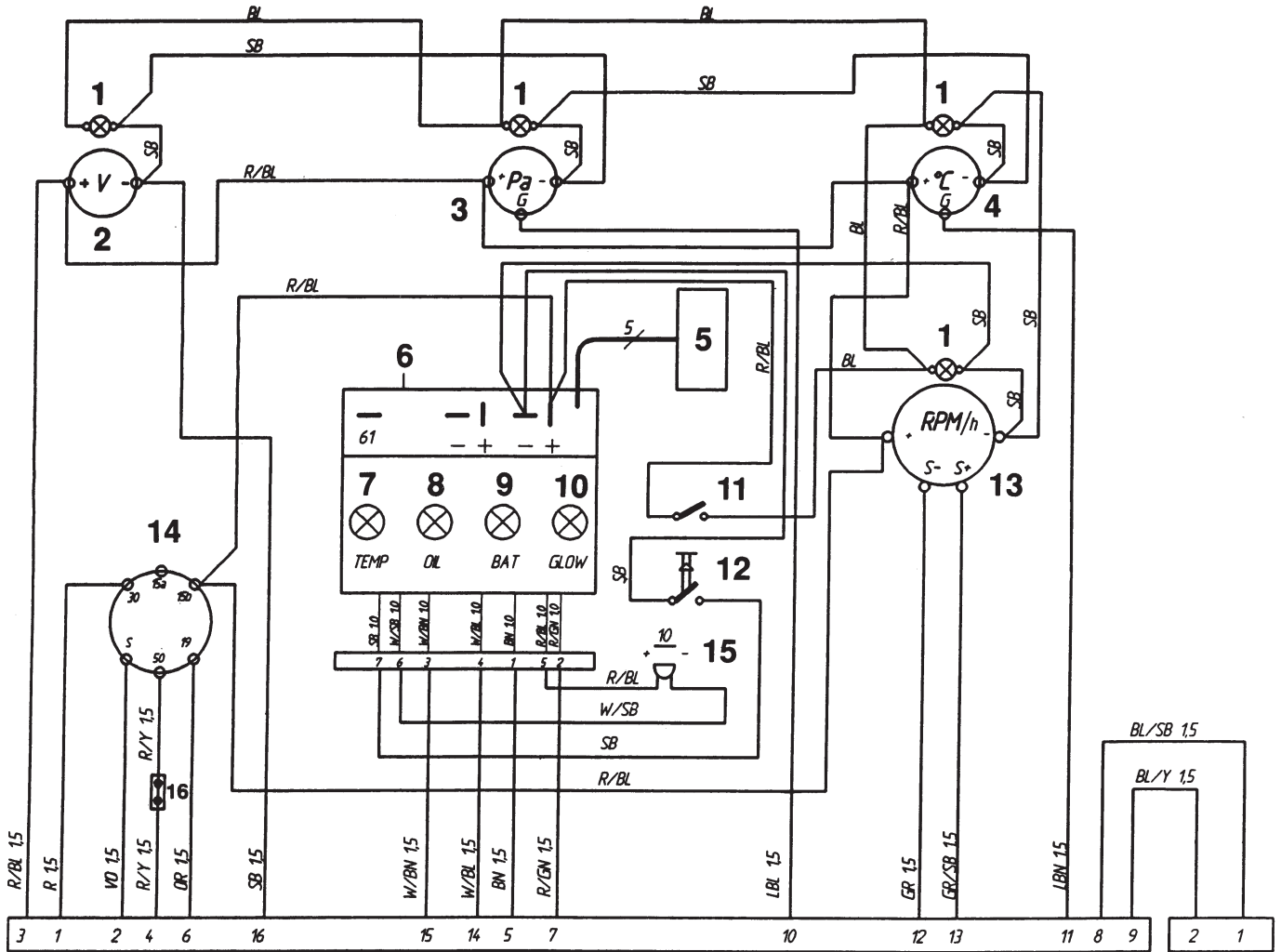

Cable colors

- BL = Blue
- LBL = Light blue
- BN = Brown
- LBN = Light brown
- GN = Green
- GR = Gray
- OR = Orange
- R = Red
- SB = Black
- VO = Violet
- W = White
- Y = Yellow

1. Instrument lighting
2. Voltmeter
3. Oil pressure gauge
4. Coolant temperature gauge
5. Connector for connection of extra warning display (extra equip.)
6. Electronic unit (alarm)
7. Warning lamp, coolant temperature
8. Warning lamp, oil pressure
9. Charge warning lamp
10. Indication lamp, glow plugs
11. Switch, instrument lighting
12. Switch - Alarm test/Acknowledge
13. Tachometer with built-in running hours timer (extra equip.). Or blanking plug
14. Key switch
15. Alarm
16. Connector for connecting neutral position switch (extra equip.)
17. 16-pin connector
18. 2-pole connector (for possible additional panel)

Cable cross section in mm² is given after the color code on the wiring diagram.

Cross section not given = 1.0 mm²

Group 20 Technical data

General

Engine designation	D2-55 A/B/C	D2-75 A
No. of cylinders	4	4
Induction system	Atmospheric pressure	Turbocharger with charge air cooler
Bore	84 mm	84 mm
Stroke	100 mm	100 mm
Cylinder volume, total	2.2 liter	2.2 liter
Power output, see sales literature		
Idling speed	850 ± 25 rpm	850 ± 25 rpm
High idle	3185 ± 15 rpm	3240 ± 15 rpm
Compression ratio	23,3:1	23,3:1
Compression pressure at starter motor speed	>27 Bar	>27 Bar
Firing sequence (cyl. no. 4 closest to flywheel)	1-3-4-2	1-3-4-2
Direction of rotation (seen from front)	Clockwise	Clockwise
Max. permissible rearwards inclination in operation	20°	20°
Max. side inclination in operation	30°	30°
Valve clearance, stationary cold engine, inlet and exhaust ...	0.20 mm	0.20 mm
Weight, engine less oil and water	225 kg	250.6 kg
Max. permitted back-pressure in exhaust system	20 kPa	20 kPa

Pistons

Material	Aluminum alloy	Aluminum alloy
Height, total	87.66-87.74 mm	87.66-87.74 mm
Height from gudgeon pin center to piston crown	47.66-47.74 mm	47.66-47.74 mm
Piston clearance	0.038-0.072 mm	0.038-0.072 mm
Front marking	"SHIBAURA"-mark inside piston shall when mounted face the fuel pump (D2-55 A/B/C & D2-75).	

Piston rings

Compression rings:		
Quantity	2	2
Upper compression ring, height	1.97-1.99 mm	1.97-1.99 mm
2nd compression ring, height	1.47-1.49 mm	1.47-1.49 mm
Oil ring:		
Quantity	1	1
Height	3.90-3.98 mm	3.90-3.98 mm
Piston ring gap in cylinder:		
Upper compression ring	0.20-0.35 mm	0.20-0.35 mm
2nd compression ring	0.20-0.40 mm	0.20-0.40 mm
Piston ring clearance in groove,		
upper compression ring	0.07-0.11 mm	0.07-0.11 mm
2nd compression ring	0.04-0.08 mm	0.04-0.08 mm
oil ring	0.02-0.06 mm	0.02-0.06 mm

Gudgeon pins

Clearance, piston pin – connecting rod bush	0.010-0.027 mm	0.010-0.027 mm
gudgeon pin – gudgeon pin hole	-0.001- +0.011 mm	-0.001- +0.011 mm
Gudgeon pin diameter	27.996-28.000 mm	27.996-28.000 mm
Conrod bush int. diameter	28.010-28.021 mm	28.010-28.021 mm
Gudgeon pin hole diameter in piston	27.999-28.005 mm	27.999-28.005 mm

	D2-55 A/B/C	D2-75 A
Cylinder head		
Height	69.7-70.3 mm	69.7-70.3 mm
Valve seat (inlet and exhaust)		
Inlet, diameter	36.35-36.45 mm	36.35-36.45 mm
Exhaust, diameter	32.35-32.45 mm	32.35-32.45 mm
Inlet, width	1.5-2.0 mm	1.5-2.0 mm
Exhaust, width	1.9-2.2 mm	1.9-2.2 mm
Crankshaft with bearings		
(Replaceable bearing shells for main and big-end bearings)		
Crankshaft, end float	0.1-0.4 mm	0.1-0.4 mm
Main bearings, radial clearance no. 1, 2, 3 & 4	0.044-0.102 mm	0.044-0.102 mm
Main bearing journals		
Diameter in mm, bearing journal, standard no. 1, 2, 3 & 4	67,957-67,970	67,957-67,970
Big end journals		
Big end, radial clearance	0,035-0.085 mm	0,035-0.085 mm
Length of bearing journal	17,70-20.60 mm	17,70-20.60 mm
Diameter, standard	51,964-51.975 mm	51,964-51.975 mm
Big end journal shells		
Thickness in mm, standard	1,482-1,495	1,482-1,495
Con rods		
Fitted with replaceable bearing shells.		
Diameter, conrod bush bearing position	30,500-30,516	30,500-30,516
bearing shell bearing position	28,010-28,021	28,010-28,021
gudgeon pin bush	28,010-28,021	28,010-28,021
End float, con rod – crankshaft	0.035-0.085 mm	0.035-0.085 mm

	D2-55 A/B/C	D2-75 A
Camshaft		
Drive	Gear wheel	Gear wheel
No of bearings	3	3
Valve timing:		
inlet valves	opens b.t.d.c.	13°
	closes a.b.d.c.	43°
exhaust valves	opens b.b.d.c.	43°
	closes a.t.d.c.	13°
Valves		
Inlet		
Valve stem diameter	6.955-6.970 mm	6.955-6.970 mm
Valve head edge	0.925-1.075 mm	0.925-1.075 mm
Clearance, valve stem - valve guide	0.03-0.06 mm	0.03-0.06 mm
Valve seat angle in cylinder head	45°	45°
Valve clearance, cold engine	0.20 mm	0.20 mm
Exhaust		
Valve stem diameter	6.94-6.95 mm	6.94-6.95 mm
Valve head edge	0.925-1.075 mm	0.925-1.075 mm
Clearance, valve stem - valve guide	0.050-0.075 mm	0.050-0.075 mm
Valve seat angle in cylinder head	45°	45°
Valve clearance, cold engine	0.20 mm	0.20 mm
Valve springs		
Length unloaded	35 mm	35 mm
with 79.4 N (8.1 kp) load	30.4 mm	30.4 mm
Pushrods		
Length, total	226 mm	226 mm
Outer diameter	6.35 mm	6.35 mm
Rocker arm mechanism		
Rocker arm shaft, diameter	14.95-14.97 mm	14.95-14.97 mm
Clearance, rocker arm shaft – rocker arm bush	0.030-0.093 mm	0.030-0.093 mm
Lubrication system		
Oil pressure, hot engine at operating speed	150-500 kPa	150-500 kPa
Oil pressure, idle	50-150 kPa	50-150 kPa
Reduction valve, opening pressure	245-345 kPa	245-345 kPa
Lubrication oil pump:		
clearance, inner - outer rotor	0.01-0.15 mm	0.01-0.15 mm
end float, rotor - cover	0.01-0.15 mm	0.01-0.15 mm
Oil grade	VDS-2, ACEA E5, API CH-4	VDS-2, ACEA E5, API CH-4
Viscosity at -5 to +50°C*	SAE 15W/40, SAE 20W/50	SAE 15W/40, SAE 20W/50
Max oil volume incl. oil filter, no engine inclination, approx.	10.6 liter	10.6 liter
Min. oil volume incl. oil filter, no engine inclination, approx.	8.9 liter	8.9 liter

*Note The temperature values refer to constant ambient temperatures

	D2-55 A/B/C	D2-75 A
Fuel system		
Injection sequence	1-3-4-2	1-3-4-2
Feed pump max. suction height	0.8 m	0.8 m
Feed pressure	15-25 kPa	15-25 kPa
Injection pump		
Injection start, crankshaft position	22.0° ± 1° b.t.d.c.	22.0° ± 1° b.t.d.c.
Pump element diameter	6 mm	6 mm
Stroke	7 mm	7 mm
Injectors		
Opening pressure (for checking)	15.2-16.2 MPa	15.2-16.2 MPa
Opening pressure (when adjusting)	15.7 MPa	15.7 MPa
Needle valve, diameter	4 mm	4 mm
Pin diameter	1 mm	1 mm
Jet angle	4°	4°
Cooling system		
Type	Over-pressure, closed cooling system	Over-pressure, closed cooling system
Freshwater system volume, approx.	9.5 liter	9.8 liter
Thermostat, qty.	1	1
Thermostat starts opening at	82° ± 4°C	82° ± 4°C
fully open at	95°C	95°C
Thermostat valve lifting height	8 mm	8 mm
Electrical system		
System voltage	12 V	12 V
Fuses	15 A	15 A
Battery capacity (starter battery)	88 Ah	88 Ah
Glow plugs:		
rated voltage	10.5 V	10.5 V
current	6.9 A	6.9 A
Alternator		
Voltage output at +20 °C	with sensor	14.2 ± 0.15 V
	without sensor	14.2 ± 0.3 V
Max current	115 A	115 A
Power, approx.	1630 W	1630 W
Suppression capacitor	2.2 µF	2.2 µF
Starter motor		
Starter motor, power app.	2.0 kW	2.0 kW

Wear tolerances

	D2-55 A/B/C	D2-75 A
General		
Compression pressure at starter motor speed (min. 200 rpm)	min. 25 Bar	min. 25 Bar
Pistons		
Piston clearance	max. 0.25 mm	max. 0.25 mm
Piston rings		
Piston ring clearance in groove:		
Compression rings	max. 0.25 mm	max. 0.25 mm
Oil scraper ring	max. 0.15 mm	max. 0.15 mm
Piston ring gap in cylinder	max. 1.0 mm	max. 1.0 mm
Gudgeon pins		
Gudgeon pin diameter	min. 27.996-28.000 mm	min. 27.996-28.000 mm
Clearance, gudgeon pin – conrod bush	max. 0.08 mm	max. 0.08 mm
gudgeon pin – gudgeon pin hole	max. 0.02 mm	max. 0.02 mm
Cylinder head		
Warping	max. 0.12 mm	max. 0.12 mm
Engine block		
Warping (head plane)	max. 0.12 mm	max. 0.12 mm
Bore	max. 84.2 mm	max. 84.2 mm
0.5 mm T.D.C.	max. 84.7 mm	max. 84.7 mm
1.0 mm T.D.C.	max. 85.2 mm	max. 85.2 mm
Crankshaft		
Out of straightness	max. 0.06 mm	max. 0.06 mm
Conrods		
Straightness, max. deviation on 100 mm measured length		
	0.15 mm	0.15 mm
Twist, max. deviation on 100 mm measured length		
	0.2 mm	0.2 mm
End float, conrod – crankshaft		
	max. 0.7 mm	max. 0.7 mm
Bearing clearance		
Main bearing	max. 0.2 mm	max. 0.2 mm
Big-end bearings	max. 0.2 mm	max. 0.2 mm

Tightening torque in Nm

Cylinder head*	100
Main bearings:	
upper to lower bearing caps	52
main bearing caps to cylinder block (hex bolts)	52
rear cap (Allen bolt)	27
Big end bearings	52
End plate/flywheel housing	25
Flywheel housing	25
Flywheel	74
Elastic coupling	22
Adapter plate to flywheel housing	22
Strainer, oil pump	10
Oil sump	10
Drain plug, oil sump	35
Timing gear cover	10
Crankshaft pulley	300
Injection pump	15
Bearing block, rocker arm shaft	33
Valve cover	14
Pressure oil pipe (cylinder block – cylinder head)	12
Injectors	64
Delivery pipes	23
Pressure valve holder	42
Reduction valve	64
Locking screw (max. fuel volume)	15
Locking screw (engine speed)	15
Glowplug	18
Oil pressure monitor	18
Coolant temperature monitor	27
Oil pressure sensor	18
Coolant temperature sensor	18

* The tightening torque given is the final tightening torque.

The cylinder head is to be tightened in three steps in the correct tightening sequence, see tightening diagram.

Oil the threads of the cylinder head bolts with clean oil.

Notes

A series of horizontal dotted lines for writing notes.

Notes

A series of horizontal dotted lines for writing notes.

Notes

A series of horizontal dotted lines for writing notes.

Report form

Do you have any comments or complaints about this manual? Please take a copy of this page, write your comments on it and send it to us. The address is at the bottom. We would appreciate it if you were to write in English or Swedish.

From:

.....

.....

.....

Refers to publication:

Publication no: Date of issue:

Suggestion/Motivation:

.....

.....

.....

.....

.....

.....

.....

.....

Date:

Name:

AB Volvo Penta
Technical Information
Dept. 42200
SE-405 08 Göteborg
Sweden

