

ST30 Round Bidata Owner's Handbook

Document number: 81075_4
Date: 1st April 2001

Important information

WARNING

Although your ST30 instrument is designed to give accurate and reliable performance, it should serve only as an aid to navigation and should never lead to the erosion of good seamanship. Always maintain a permanent watch and be aware of situations as they develop.

EMC conformance

All Raymarine equipment and accessories are designed to the best industry standards for use in the leisure marine environment.

The design and manufacture of Raymarine equipment and accessories conform to the appropriate Electromagnetic Compatibility (EMC) standards, but correct installation is required to ensure that performance is not compromised.

Handbook information

To the best of our knowledge, the information in this handbook was correct when it went to press. However, the Raymarine policy of continuous product improvement may change product specifications without notice. Consequently, unavoidable differences may occur between the product and the handbook from time to time, for which Raymarine cannot accept liability.

Contents

- Important information i**
 - WARNING i
 - EMC conformance i
 - Handbook information i

- Preface vii**

- Parts supplied viii**

- Chapter 1: Operation 1**
 - 1.1 Introduction 1
 - 1.2 Depth key functions 2
 - Water depth 2
 - Shallow alarm 2
 - Adjusting shallow depth 2
 - Silencing the shallow alarms 3
 - Turning shallow alarm ON and OFF 3
 - Offset 3
 - Default display 3
 - Loss of signal 3
 - 1.3 Speed key functions 4
 - Speed 4
 - Trip distance 4
 - Resetting Trip Distance 4
 - Ships log 4
 - 1.4 LCD illumination 5

- Chapter 2: Maintenance and Fault Finding 7**
 - 2.1 Maintenance 7
 - Servicing and safety 7
 - Cleaning the instrument 7

Condensation	7
Cables	8
2.2 Fault finding	8
Chapter 3: Installation	9
3.1 Introduction	9
EMC installation guidelines	9
Suppression ferrites	10
Connections to Other Equipment	10
3.2 Installing the instrument	10
3.3 Connecting the power supply direct	12
3.4 Power via SeaTalk	13
3.5 Adding an independent lighting switch	13
3.6 Installing the Biducer transducer	14
Cable connections	14
3.7 Calibration requirement	14
Chapter 4: Calibration	15
4.1 Introduction	15
EMC conformance	15
4.2 Basic calibration	15
Offset entry	16
Depth units	17
Speed and log units	17
Log calibration	17
Procedure	18
Exiting basic calibration	18
4.2 Intermediate calibration	18
Software version	19
Repeater	19
Saving intermediate calibration	19

- Exit intermediate calibration without saving 19
- Default display 20
- 4.3 Extended calibration 20
 - Calibration 21
 - Boat show 21
 - Depth and speed damping 21
 - Saving extended calibration 21
 - Exit extended calibration without saving 21
- Specification 23**

Preface

Thank you for purchasing a Raymarine product. We are sure your ST30 instrument will give you many years of trouble-free operation.

This instrument is designed to provide reliable performance, even under the most demanding conditions.

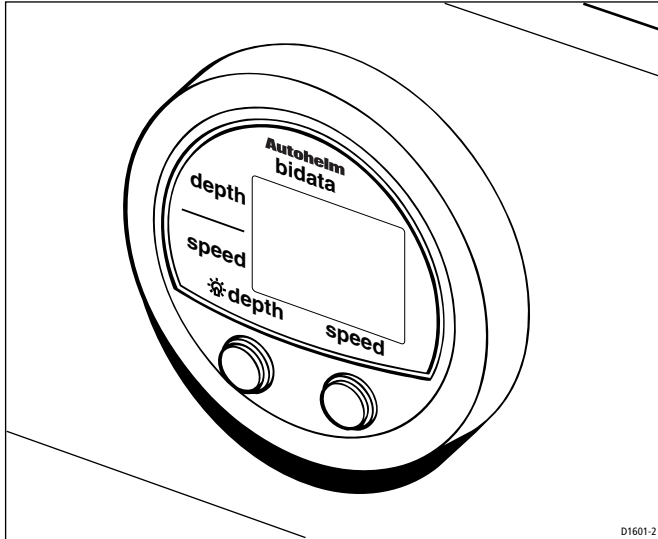

Parts supplied

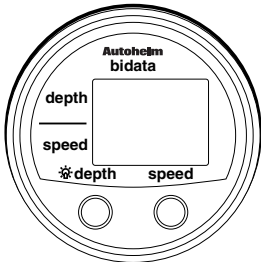

ST30 Round Bidata instrument

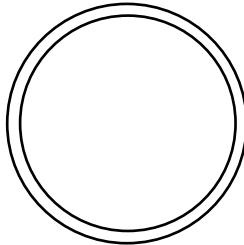

Sealing gasket

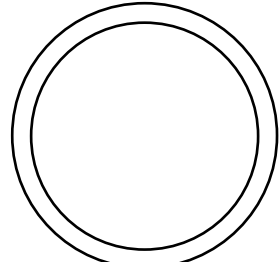

Display bezel
(1 black & 1 grey supplied)

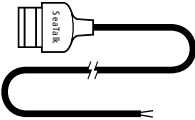

2 m (6.5 ft) power cable

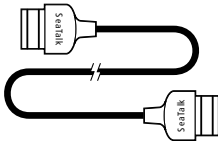

Interconnection cable

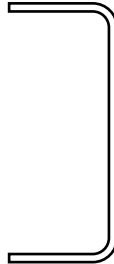

"C" bracket



Fixing studs (x2)



Thumb nuts (x2)

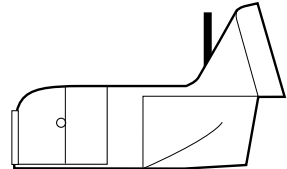

Biducer

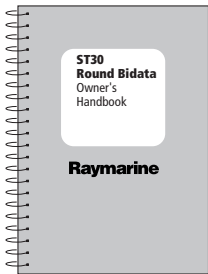

Owner's Handbook
Warranty document and fitting
template included in Handbook

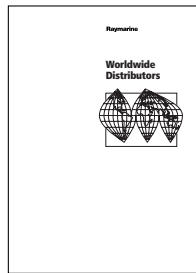

Worldwide Service Centre
Handbook

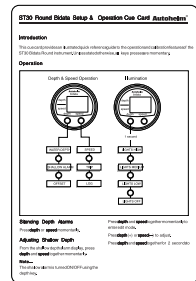

Cue Card

Notes:

The items shown are supplied for an ST30 Round Bidata system. If an instrument is purchased separately, a transducer is not included. If any item is not present, contact your Raymarine Dealer.
If the ST30 Round Bidata is to be flush mounted, do not fit a display bezel .

Chapter 1: Operation

1.1 Introduction

The ST30 Round Bidata instrument is designed for the powerboat market, and displays speed and depth information simultaneously on a split LCD. The Bidata can also display trip and log distances, sound a user-defined shallow alarm, and function as a repeater.

The instrument can be surface or flush mounted and fits the standard 85.7 mm (3 ³/₈ inch) diameter facia apertures, common on many sports boats.

The Bidata uses an easy-to-install transom mount transducer (Biducer) combining both speed and depth elements in a single housing.

If the Bidata is used in conjunction with a SeaTalk autopilot, the speed input provided by the instrument enhances the pilot's steering performance.

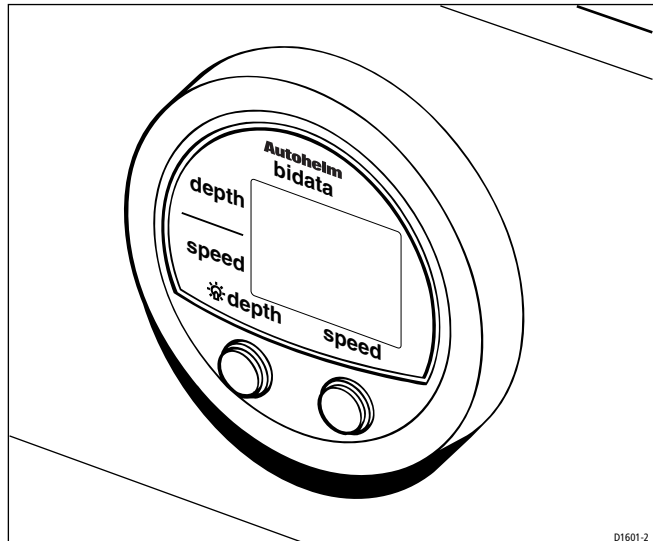

The operating procedures are presented as a combination of flow charts and text. Unless otherwise stated, the illustrated key presses are momentary.

The Bidata can display depth and speed information in metric and imperial units. These are set during basic calibration (see *Chapter 4, Calibration*).

1.2 Depth key functions

The following flow chart shows the depth key functions.

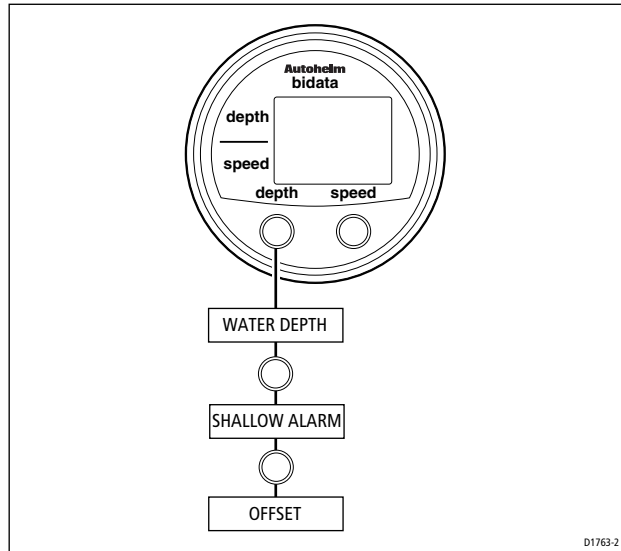

Water depth

Depth is displayed in feet (0 to 400 ft) or metres (0 to 120 m).

Shallow alarm

The shallow alarm displays the depth (feet or metres) at which point audible and visual alarms will be triggered. These alarms can be silenced by pressing the **speed** or **depth** key.

Adjusting shallow depth

1. From the shallow depth alarm display, press **depth** and **speed** together momentarily to display CAL.
2. Press **depth** and **speed** together again momentarily to enter edit mode (+ and - displayed).
3. Press **depth** to increase and **speed** to reduce the displayed value.
4. Press and hold **depth** and **speed** together for 2 seconds, to exit edit mode and save the new value.

Silencing the shallow alarms

Press **speed** or **depth** to silence the audible alarm for a period of two minutes. If, after 2 minutes, the water depth is still below the alarm setting, the alarm will be activated again.

Note: When the audible alarm is silenced the alarm icon continues to flash.

Turning shallow alarm ON and OFF

1. Ensure the shallow alarm screen is displayed.
2. Press **depth** and **speed** together momentarily to enter CAL mode.
3. Press **depth** to switch the alarm ON or OFF.
4. Press **depth** and **speed** together for 2 seconds to exit CAL mode.

Offset

This is the distance (feet or metres) from the Biducer to the bottom of the hull or to the waterline, which can be a positive (+) or negative (-) value.

Default display

The depth display will always default back to water depth 8 seconds after the last key press.

Loss of signal

If there are no depth echoes for 10 seconds, the feet/metres legend flashes and the last recorded depth is displayed until a new echo is received.

1.3 Speed key functions

The following flow chart shows the speed key functions.

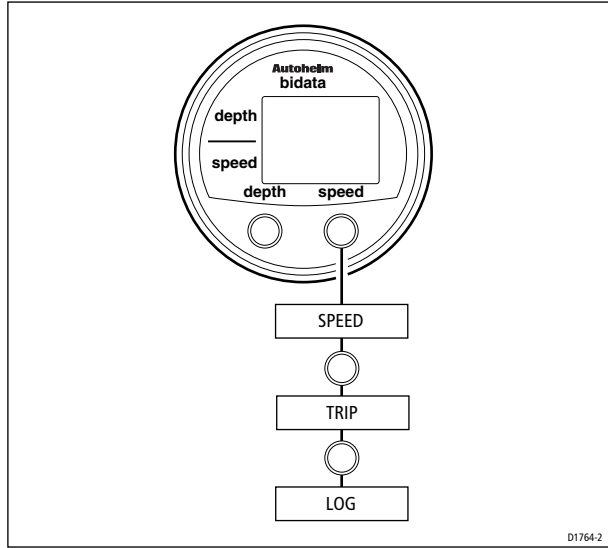

Speed

The speed display can be either knots (Kts), miles per hour (Mph), or kilometres per hour (Kph).

Trip distance

Trip is the distance covered between power on and power off. This can be nautical miles (NM), kilometres (KM), or statute miles (SM).

Resetting Trip Distance

Press and hold the **speed** key until the trip distance is zeroed - distance flashes after 1 second and during the resetting process.

Ships log

When this value exceeds 999 NM, SM, or KM, the Bidata displays the log as thousands (th) and, after 3 seconds, hundreds, tens, and units. For example, 1525 nm would be displayed as 1th then 525.

1.4 LCD illumination

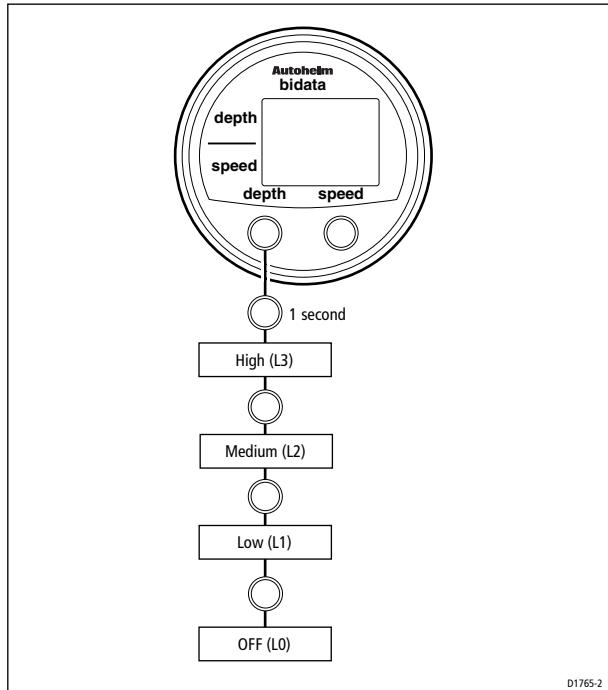

The Bidata has four illumination settings, off, low (L1), medium (L2), and high (L3).

The Bidata automatically returns to normal operation 5 seconds after the last key press.

If the shallow depth alarm is activated the illumination display is ignored.

Chapter 2: Maintenance and Fault Finding

2.1 Maintenance

Servicing and safety

- Raymarine equipment should be serviced only by authorised Raymarine service technicians. They will ensure that service procedures and replacement parts used will not affect performance. There are no user serviceable parts in any Raymarine product.
- Some products generate high voltages, so never handle the cables/connectors when power is being supplied to the equipment.
- When powered up, all electrical equipment produces electromagnetic fields. These can cause adjacent pieces of electrical equipment to interact with one another, with a consequent adverse effect on operation. In order to minimise these effects and enable you to get the best possible performance from your Raymarine equipment, guidelines are given in the installation instructions, to enable you to ensure minimum interaction between different items of equipment, i.e. ensure optimum Electromagnetic Compatibility (EMC).
- Always report any EMC-related problem to your nearest Raymarine dealer. We use such information to improve our quality standards.
- In some installations, it may not be possible to prevent the equipment from being affected by external influences. In general this will not damage the equipment but it can lead to spurious resetting action, or momentarily may result in faulty operation.

Cleaning the instrument

Periodically clean the instrument should be cleaned with a soft, damp cloth. Do NOT use chemical or abrasive materials.

Condensation

Certain atmospheric conditions may cause a small amount of condensation to form on the instrument window. This will not harm the instrument and will clear after the instrument has been switched on for a short period.

Cables

Periodically examine the SeaTalk, Biducer, and power cables for evidence of damage to the outer shield, and if necessary, replace with genuine Raymarine cables.

2.2 Fault finding

If you appear to have a problem with your Bidata unit, please refer to this table before contacting your Raymarine Dealer.

Fault	Action
Display blank	Poor power cable connection or cable damaged. Check the circuit breaker/fuse.
No speed information	Biducer paddlewheel obstructed. Poor Biducer cable connection or cable damaged.
No depth information	Aerated water, boat wakes or propeller wash. Normal operation will return once you are clear of the disturbed water. Poor Biducer cable connection or cable damaged.
Speed/log information inaccurate	Log calibration has not been carried out (see Chapter 4).
Unable to enter basic and intermediate calibration	Calibration is set to off (see Chapter 4).
Feet/metres display flashes continuously	Poor Biducer cable connection or cable damaged.

Chapter 3: Installation

3.1 Introduction

Please read this chapter thoroughly before attempting to install the instrument and transducer. Always use genuine Raymarine cables. The use of unapproved/inferior cables, for which Raymarine cannot be held liable, could affect the performance of the Bidata and other instruments on the SeaTalk bus.

The Bidata may be flush mounted by installing the instrument from behind the instrument panel. **The display bezel must not be assembled to the instrument if the Bidata is to be flush mounted.**

EMC installation guidelines

All Raymarine equipment and accessories are designed to the best industry standards for use in the leisure marine environment.

Their design and manufacture conforms to the appropriate Electromagnetic Compatibility (EMC) standards, but correct installation is required to ensure that performance is not compromised. Although every effort has been taken to ensure that they will perform under all conditions, it is important to understand what factors could affect the operation of the product.

The guidelines given here describe the conditions for optimum EMC performance, but it is recognised that it may not be possible to meet all of these conditions in all situations. To ensure the best possible conditions for EMC performance within the constraints imposed by any location, always ensure the maximum separation possible between different items of electrical equipment.

For **optimum** EMC performance, it is recommended that **wherever possible**:

- Raymarine equipment and cables connected to it are:
 - At least 1 m (3 ft) from any equipment transmitting or cables carrying radio signals e.g. VHF radios, cables and antennas. In the case of SSB radios, the distance should be increased to 2 m (7 ft).
 - More than 2 m (7 ft) from the path of a radar beam. A radar beam can normally be assumed to spread 20 degrees above and below the radiating element.

- The equipment is supplied from a separate battery from that used for engine start. Voltage drops below 10 V in the power supply to our products, and starter motor transients, can cause the equipment to reset. This will not damage the equipment, but may cause the loss of some information and may change the operating mode.
- Raymarine specified cables are used at all times. Cutting and rejoining these cables can compromise EMC performance and so must be avoided unless doing so is detailed in the installation manual.
- If a suppression ferrite is attached to a cable, this ferrite should not be removed. If the ferrite needs to be removed during installation it must be reassembled in the same position.

Suppression ferrites

The following illustration shows typical cable suppression ferrites fitted to Raymarine equipment. Always use the ferrites supplied by Raymarine.

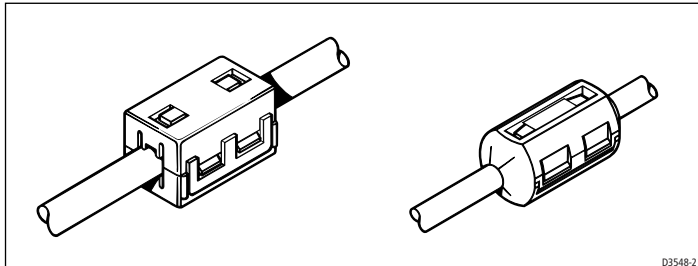

Connections to Other Equipment

If your Raymarine equipment is to be connected to other equipment using a cable not supplied by Raymarine, a suppression ferrite **MUST** always be fitted to the cable close to the Raymarine unit.

3.2 Installing the instrument

When selecting a location for the Bidata instrument, ensure that:

- It is at least 230 mm (9 in) from a compass
- It is at least 500 mm (20 in) from radio receiving equipment
- There is sufficient clearance behind the bulkhead to house the rear of the instrument, fixing studs, “C” bracket, and SeaTalk cables.

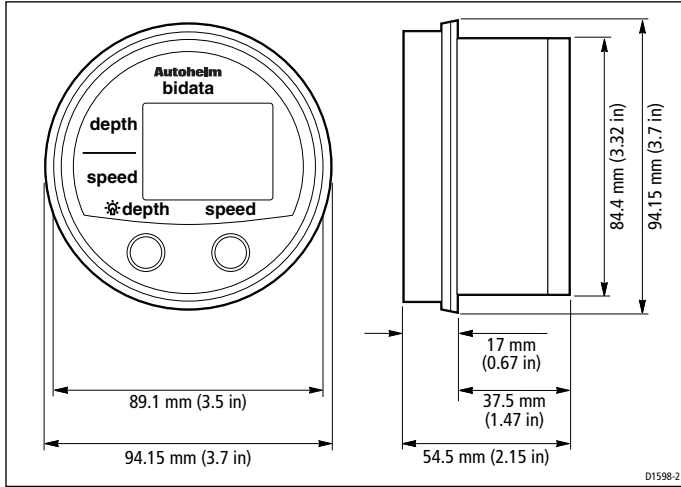

CAUTION

Where it is necessary to cut holes (e.g. for cable routing and instrument mounting), ensure that these will not cause a hazard by weakening critical parts of the vessel’s structure. If in doubt, seek advice from a reputable boat builder.

1. If appropriate, use the template provided near the back of this book to mark the intended location of the Bidata instrument.
2. Use a tank cutter to machine an 85 mm (3 3/8 in) clearance hole for the instrument.

Note: If you do not wish to use a tank cutter, the hole can be machined using a hole saw and a file.

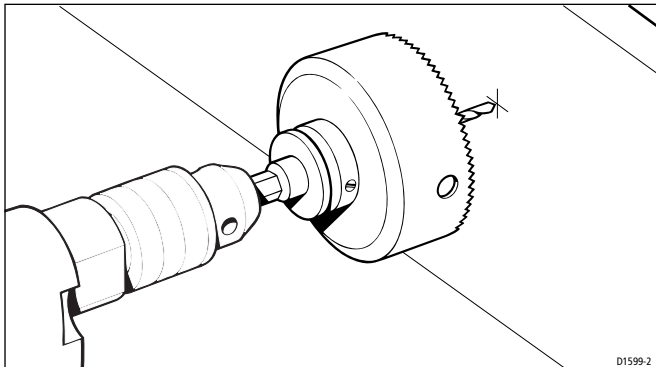

2. Remove any burrs from the aperture.

3. Pass the SeaTalk and transducer cables through the seal. Plug these cables into appropriate instrument ports.
4. Secure the instrument using the fixing studs, "C" bracket, and thumb nuts as shown.

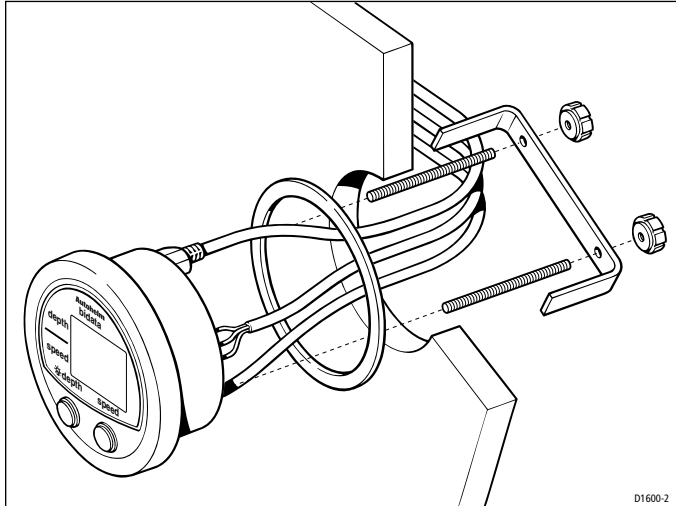

D1600-2

3.3 Connecting the power supply direct

CAUTION

Ensure that the power supply is protected by a 5 A fuse or circuit breaker.

1. Plug the 2 m (6 ft) power cable into one of the SeaTalk ports.
2. Connect the red wire to 12 V (+) and the screen to 0 V (-). Protect the circuit with a 5 A fuse/circuit breaker.

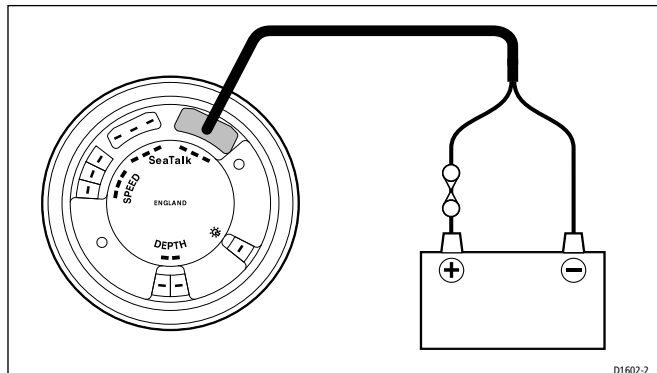

D1602-2

3.4 Power via SeaTalk

CAUTION

Ensure that the power supply is protected by a 5 A fuse or circuit breaker.

If the Bidata is to be used with other SeaTalk instruments, the power supply is passed from instrument to instrument via the daisy loom cable as shown.

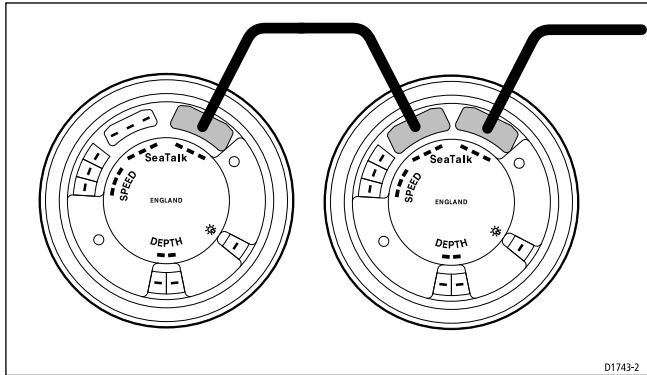

3.5 Adding an independent lighting switch

When the Bidata is part of a SeaTalk system the lighting is controlled from the keypad or from another SeaTalk instrument on the bus.

If you have an independent lighting switch, this can be connected to the * terminal so that the Bidata lighting can be switched with your existing equipment.

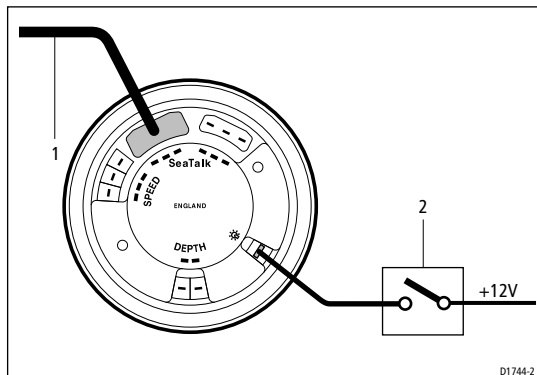

1 Power cable 2 Lamp connection to instrument panel

3.6 Installing the Biducer transducer

The ST30 Round Bidata is supplied with a combined speed and depth transducer (Biducer). This should be installed in accordance with the instructions provided.

Cable connections

The cable from the Biducer consists of five cores which should be connected to the Bidata as follows:

Cable colour	Bidata connection
Green	Green SPEED
Screen	Grey SPEED
Red	Red SPEED
Blue	Blue DEPTH
Black	Black DEPTH

3.7 Calibration requirement

Once installation is complete and before you use your instrument, carry out the calibration procedures detailed in *Chapter 4, Calibration*.

Chapter 4: Calibration

4.1 Introduction

This chapter describes how to set and adjust features contained in the basic, intermediate, and extended calibration menus. The calibration procedures must be carried out before the equipment is used operationally, to optimise the performance of the instrument with the vessel.

All key presses are momentary unless otherwise stated.

EMC conformance

Always check the installation before going to sea to make sure that it is not affected by radio transmissions, engine starting etc.

4.2 Basic calibration

Use the following flow chart to carry out basic calibration.

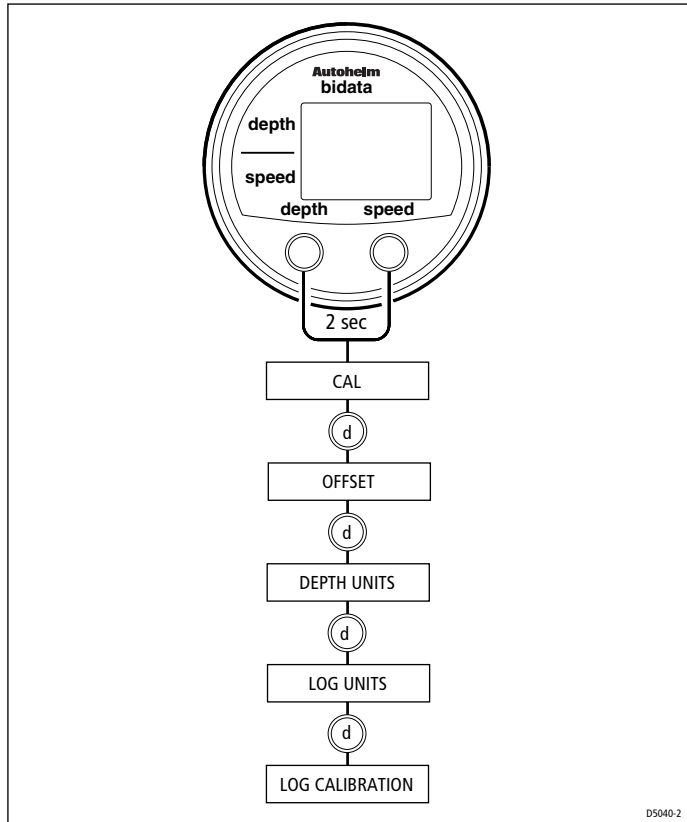

D5040-2

If CAL OFF is displayed, press **depth** or **speed** to return to normal operation then use the *Extended calibration* procedure to turn on basic calibration.

Offset entry

This option is used to select whether the displayed water depth is from the surface or below the Biducer.

- Set a 0 (zero) offset, to give the depth from the transducer to the seabed.
 - Set a negative offset, to give the depth from the keel to the seabed.
 - Set a positive offset, to give the depth from the waterline to the seabed.
1. At the OFFSET display, press **depth** and **speed** together momentarily to enter edit mode.

2. Use the **depth** key to increase or **speed** to decrease the displayed offset.
3. Press **depth** and **speed** together momentarily to exit edit mode.

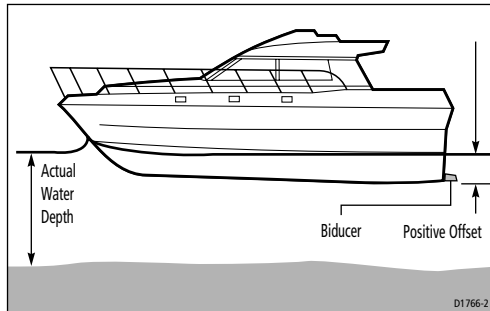
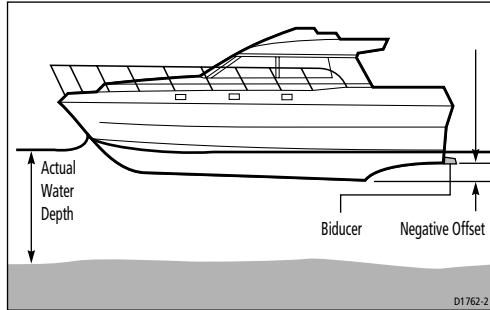

Depth units

The available depth units are metres or feet. These units are toggled with the **depth** or **speed** key.

Speed and log units

The available speed and log units are Kmh, Mph, Kts, SM and NM. These units are toggled with the **depth** or **speed** key.

Log calibration

To ensure correct speed and log values are displayed, a correction factor must be entered at the log display.

The correction factor = $\text{Charted distance} \div \text{Average Distance}$.

The charted distance is the distance between two charted objects. Ideally, this should be about 1 nm.

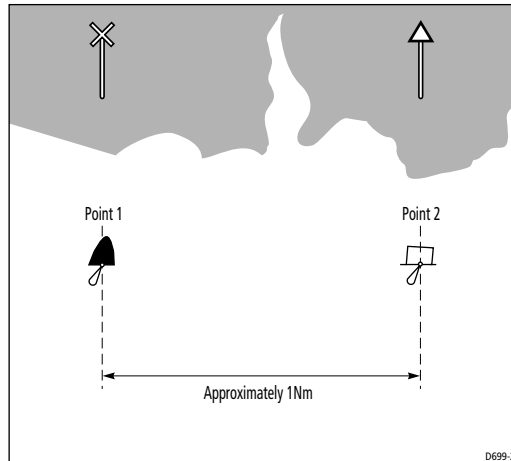

Procedure

1. With the trip display active, motor from “point 1” to “point 2” and record the distance displayed by the Bidata.
2. Motor from “point 2” to “point 1” and record the displayed distance.
3. Add the recorded distances together and then divide by two to obtain the average.
4. At the LOG calibration display, press **depth** and **speed** together momentarily to enter edit mode.
5. Enter the correction factor (charted distance divided by the average) using the **depth** key to increase the displayed value and **speed** to decrease the value.
6. Press **depth** and **speed** together momentarily to exit edit mode.

Exiting basic calibration

Press and hold **depth** and **speed** together for 2 seconds.

4.2 Intermediate calibration

Use the following flow chart to carry out intermediate calibration.

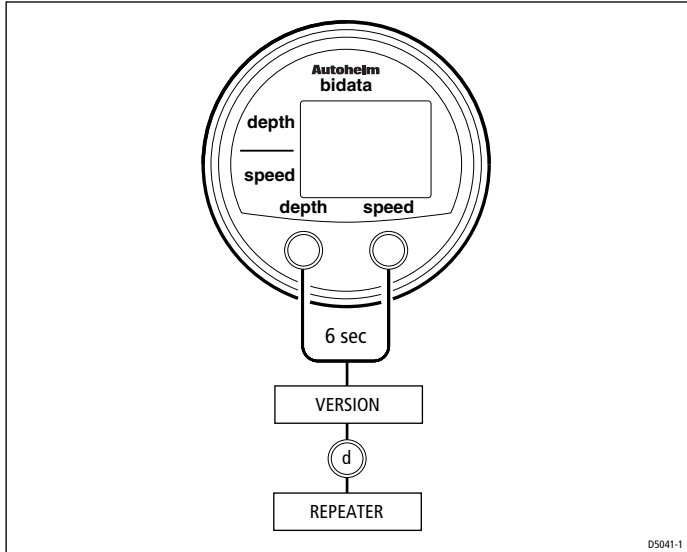

D5041-1

Software version

Displays the Bidata software version.

Repeater

The Bidata can be used as a master instrument connected directly to the transducer, or, alternatively, as a repeating unit displaying speed and depth information from another instrument.

Press **speed** to toggle between MASTER (R0) and REPEATER (R1) operating modes.

In repeater mode:

- You cannot enter basic calibration.
- You cannot view or adjust alarms or offsets, or carry out log calibration.

Saving intermediate calibration

Press and hold **depth** and **speed** for 2 seconds.

Exit intermediate calibration without saving

Press **depth** and **speed** together momentarily.

Default display

The Bidata returns to normal operation 8 seconds after the last key press.

4.3 Extended calibration

Use the following flow chart to carry out extended calibration.

The extended calibration features illustrated below are cycled using the **depth** key.

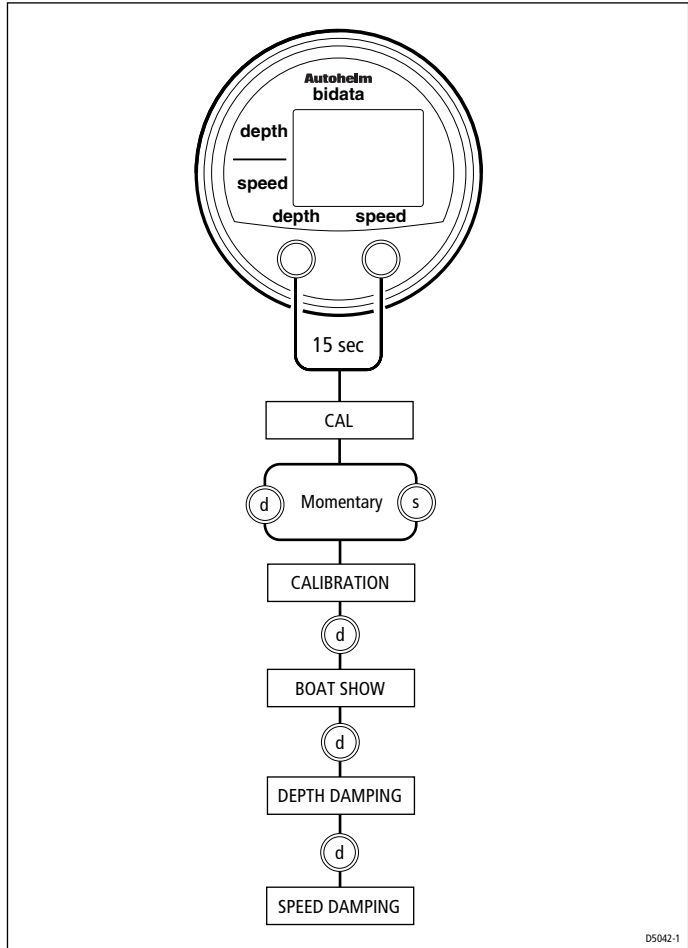

Calibration

This screen controls access to basic calibration, to protect the settings from accidentally being changed. Use the **speed** key (toggle action) to select the required setting: CAL ON (1) or CAL OFF (0).

Boat show

This is a simulation program for dealer use only: 1 = ON and 0 = OFF.

Depth and speed damping

Damping controls the rate at which the displayed data is updated. The selectable range, adjusted using the **speed** key, is between 1 and 15, with 1 providing a rapid update and 15 a slow but smooth display update.

Saving extended calibration

Press and hold **depth** and **speed** together for 2 seconds.

Exit extended calibration without saving

Press **depth** and **speed** together momentarily.

Specification

Voltage range:	10 V to 16.5 V maximum (12 V nominal)
Size:	94.15 mm x 54.5 mm
Depth range:	0 to 120 metres 0 to 400 feet
Speed range:	0 to 99.9 knots, mph, or kph
Trip:	0 to 999 nm, sm, or km
Log:	0 to 5999 nm, sm, or km
Shallow alarm:	3 to 33 feet 1 to 10 metres
Depth offset:	-9.9 to +9.9 feet -4.0 to +4.0 metres
Illumination:	3 levels via SeaTalk Single level via 12 V switch
Operating modes:	Master or repeater
Transducer type:	Transom mount Biducer



ST30 Round Bidata Template

Cut out
shaded area only

Cut hole to 86 mm
(3³/₈ in) diameter (max.)



Limited Warranty Certificate

Raymarine warrants each new Light Marine/Dealer Distributor Product to be of good materials and workmanship, and will repair or exchange any parts proven to be defective in material and workmanship under normal use for a period of 2 years/24 months from date of sale to end user, except as provided below.

Defects will be corrected by Raymarine or an authorized Raymarine dealer. Raymarine will, except as provided below, accept labor cost for a period of 2 years/24 months from the date of sale to end user. During this period, except for certain products, travel costs (auto mileage and tolls) up to 100 round trip highway miles (160 kilometres) and travel time of 2 hours, will be assumed by Raymarine only on products where proof of installation or commission by authorized service agents, can be shown.

Warranty Limitations

Raymarine Warranty policy does not apply to equipment which has been subjected to accident, abuse or misuse, shipping damage, alterations, corrosion, incorrect and/or non-authorized service, or equipment on which the serial number has been altered, mutilated or removed.

Except where Raymarine or its authorized dealer has performed the installation, it assumes no responsibility for damage incurred during installation.

This Warranty does not cover routine system checkouts or alignment/calibration, unless required by replacement of part(s) in the area being aligned.

A suitable proof of purchase, showing date, place, and serial number must be made available to Raymarine or authorized service agent at the time of request for Warranty service.

Consumable items, (such as: Chart paper, lamps, fuses, batteries, styli, stylus/drive belts, radar mixer crystals/diodes, snap-in impeller carriers, impellers, impeller bearings, and impeller shaft) are specifically excluded from this Warranty.

Magnetrons, Cathode Ray Tubes (CRT), TFT Liquid Crystal Displays (LCD) and cold cathode fluorescent lamps (CCFL), hailer horns and transducers are warranted for 1 year/12 months from date of sale. These items must be returned to a Raymarine facility.

All costs associated with transducer replacement, other than the cost of the transducer itself, are specifically excluded from this Warranty.

Overtime premium labor portion of services outside of normal working hours is not covered by this Warranty.

Travel cost allowance on certain products with a suggested retail price below \$2500.00 is not authorized. When/or if repairs are necessary, these products must be forwarded to a Raymarine facility or an authorized dealer at owner's expense will be returned via surface carrier at no cost to the owner.

Travel costs other than auto mileage, tolls and two (2) hours travel time, are specifically excluded on all products. Travel costs which are excluded from the coverage of this Warranty include but are not limited to: taxi, launch fees, aircraft rental, subsistence, customs, shipping and communication charges etc. Travel costs, mileage and time, in excess to that allowed must have prior approval in writing.

TO THE EXTENT CONSISTENT WITH STATE AND FEDERAL LAW:

(1) THIS WARRANTY IS STRICTLY LIMITED TO THE TERMS INDICATED HEREIN, AND NO OTHER WARRANTIES OR REMEDIES SHALL BE BINDING ON RAYMARINE INCLUDING WITHOUT LIMITATION ANY WARRANTIES OF MERCHANTABILITY OR FITNESS FOR A PARTICULAR PURPOSE.

(2) Raymarine shall not be liable for any incidental, consequential or special (including punitive or multiple) damages.

All Raymarine products sold or provided hereunder are merely aids to navigation. It is the responsibility of the user to exercise discretion and proper navigational skill independent of any Raymarine equipment.

Raymarine

Factory Service Centers

United States of America

Raymarine Inc
22 Cotton Road, Unit D
Nashua, NH 03063-4219, USA

Telephone: +1 603 881 5200
Fax: +1 603 864 4756
www.raymarine.com

Sales & Order Services

Telephone: +1 800 539 5539 Ext. 2333 or
+1 603 881 5200 Ext. 2333

Technical Support

Telephone: +1 800 539 5539 Ext. 2444 or
+1 603 881 5200 Ext. 2444
Email: techsupport@raymarine.com

Product Repair Center

Telephone: +1 800 539 5539 Ext. 2118

UK, Europe, Middle East, Far East

Raymarine Ltd
Anchorage Park, Portsmouth
PO3 5TD, England

Telephone: +44 (0)23 9269 3611
Fax: +44 (0)23 9269 4642
www.raymarine.com

Customer Support

Telephone: +44 (0)23 9271 4713
Fax: +44 (0)23 9266 1228

Email: techsupport@raymarine.com

Stick barcode label here

Purchased from

Purchase date

Dealer address

Installed by

Installation date

Commissioned by

Commissioning date

Owner's name

Mailing address

This portion should be completed and retained by the owner.