



T4.155 4.380 TDI 4.390 TDI

**WORKSHOP MANUAL
4 Cylinders**

ENGINE BASE
 **TOYOTA**

NANNI INDUSTRIES 11 Av MARIOTTE 33260 LA TESTE FRANCE Tel: +33 5 56 22 30 60 Fax: +33 5 56 22 30 79
E-mail: contact@nannidiesel.com Web: www.nannidiesel.com
S.A.S au capital social de 2 040 000 € R.C.S Bordeaux B 380 707 638 000 17 APE 291 A TVA: FR 15380707638

SOMMAIRE DU MANUEL D'ATELIER NANNI DIESEL Base M1KZ T 4.155 / 4.380 TDI / 4.390 TDI

ALL TIGHTENING TORQUES ARE INDICATED IN Nm and in kgf/cm

1st part:

Maintenance Manual

- | | |
|------------------------------|--|
| 4 Main components | 28 Setting injection timing |
| 7 Safety information | 31 Replacing the timing belt |
| 9 General information | 36 Compression measurement |
| 10 Putting into service | 38 Piston protrusion, cylinder head tightening |
| 13 Engine operation | 42 Marinsation - servicing |
| 18 Servicing | 45 Electricity, panel C3 |
| 19 Technical sheet | 51 Electricity, engine harnesses |
| 20 Recommendations | 53 Special tools |
| 21 Alternator belts | 54 Exploded view of M1KZ base |
| 22 Glow plugs | |
| 23 Adjusting valve clearance | |

2nd part:

Engine base disassembly and reassembly

- | | |
|----------------------------------|---|
| 71 Tightening torques (standard) | 134 Fresh water pump and sender thermostat |
| 74 Specific tightening torques | 139 Thermostat |
| 74 Engine characteristics | 141 Pre-heating |
| 78 Basic tooling | 144 Oil pressure, oil injectors, oil pump, oil radiator |
| 79 Timing pinions | 161 Turbo charger |
| 99 Cylinder head | 163 Cylinder block |
| 124 Injection pump and injectors | |

The technical data given in this manual is the latest available at the date of printing and is subject to modification without notice.

Manuel de Maintenance

MOTEUR Base M1KZ

T4.155 4.380 TDI 4.390 TDI



T4.155 4.380 TDI 4.390 TDI

(PART ONE)

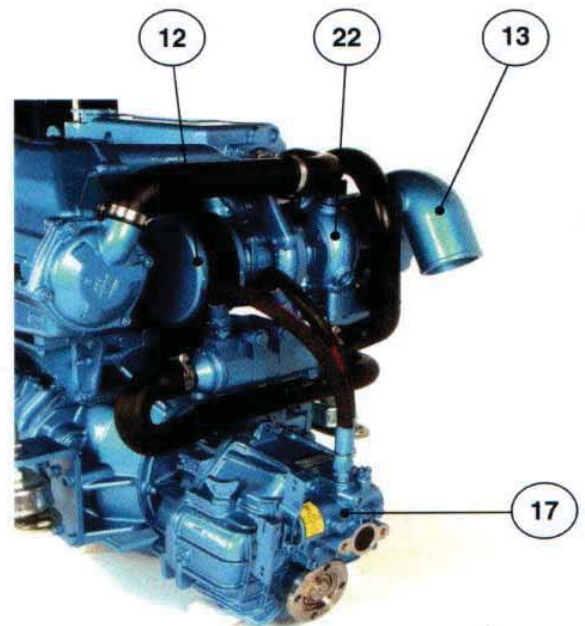
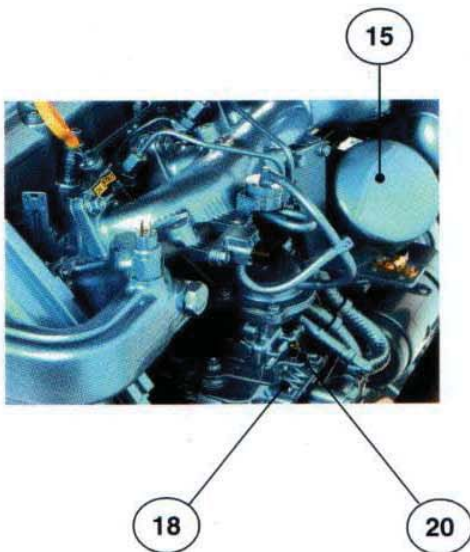
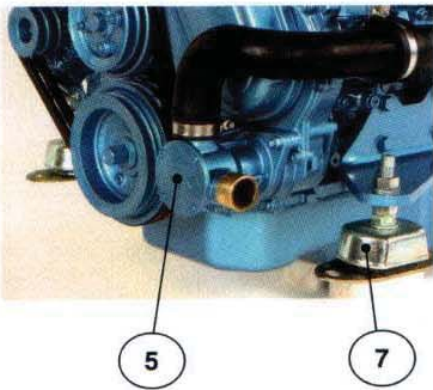
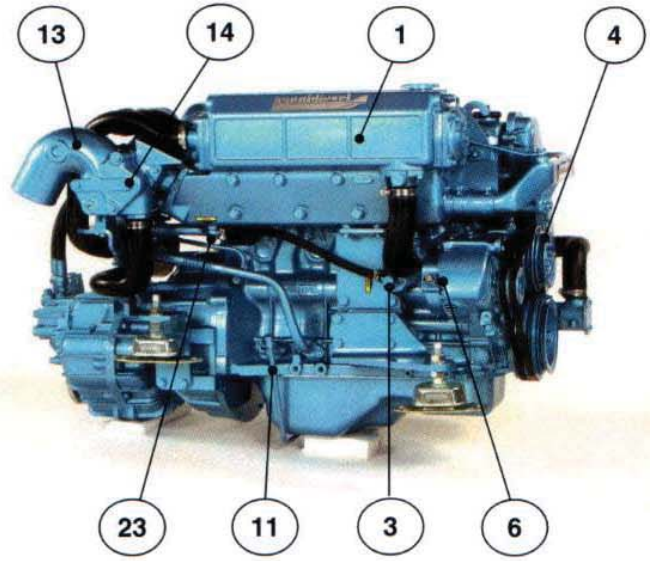
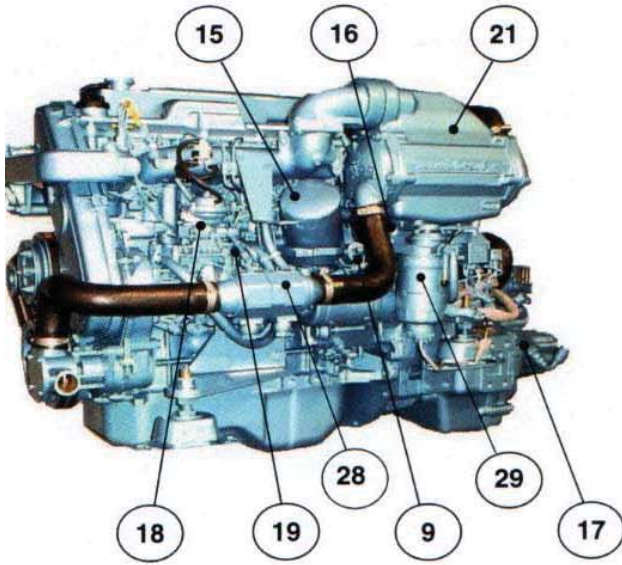

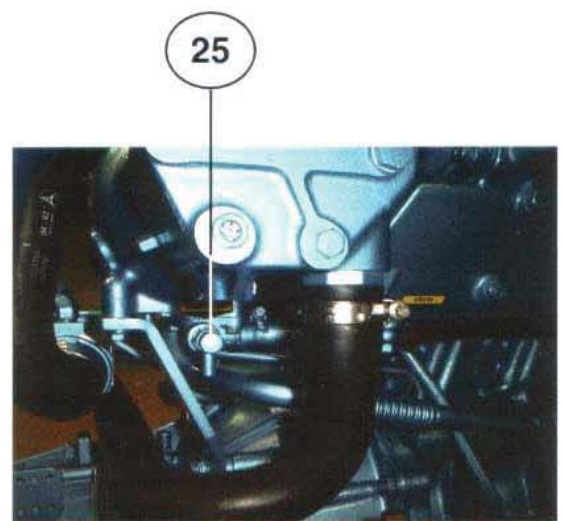
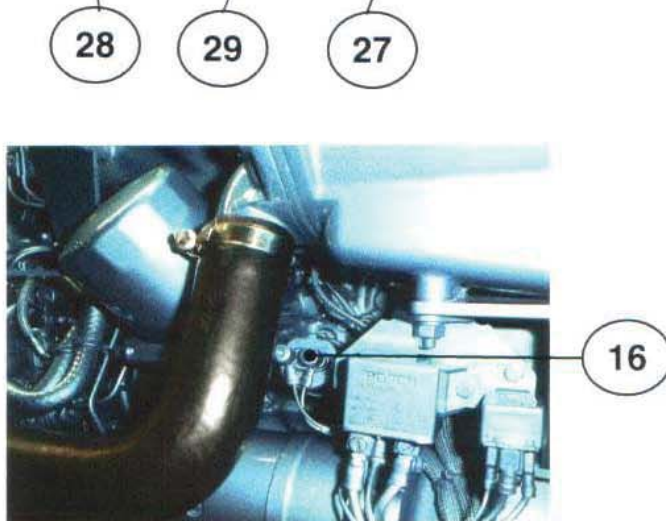
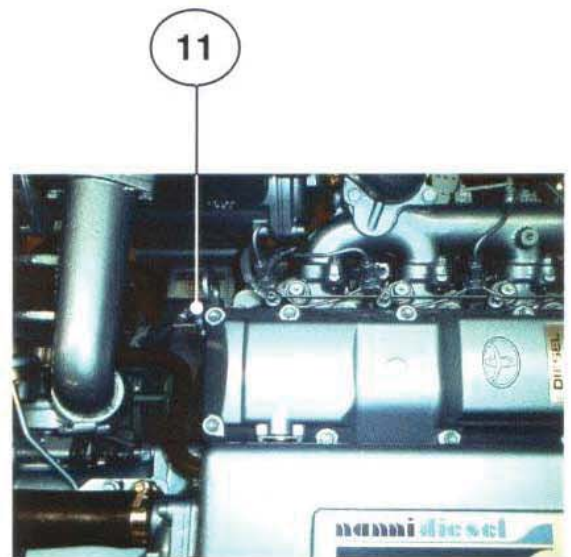
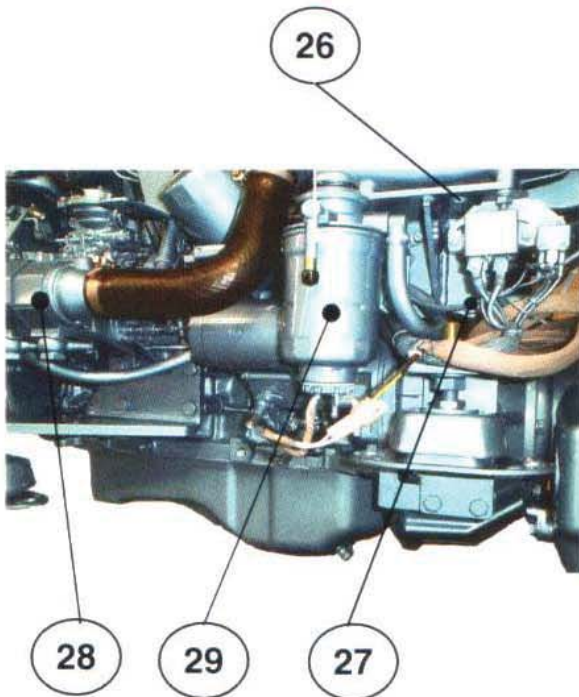
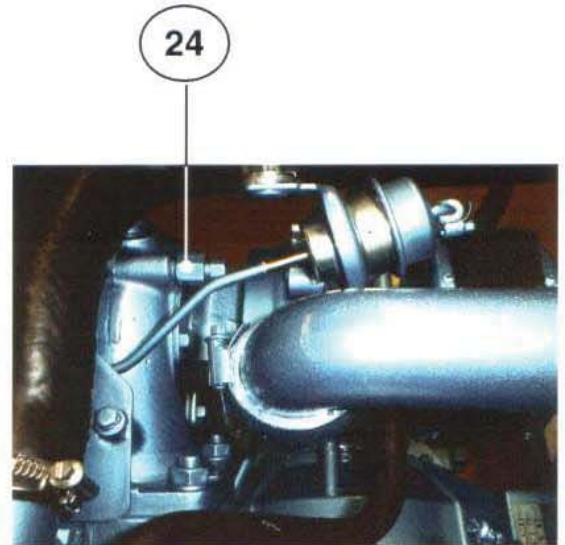
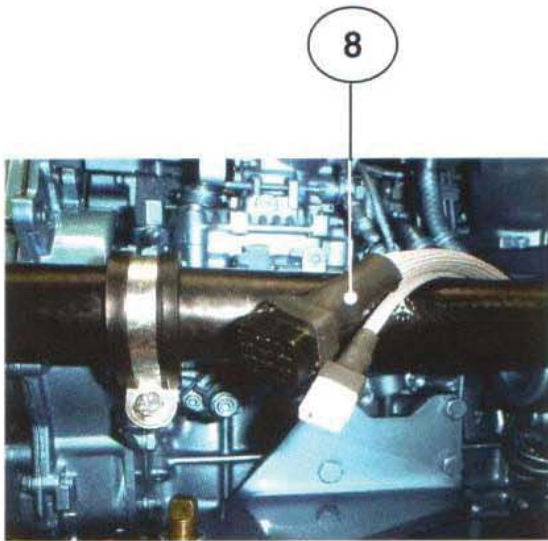

SAFETY INFORMATION

This operating manual has been published to help you use your engine and its equipment. Numerous important instructions are given in this manual and need to be observed when operating the engine.

The operator must read this manual.

This manual must always be kept where the engine is used.

SAFETY SYMBOLS

These symbols are used to indicate a danger. The purpose of these symbols is to draw your attention to articles or operations that may be dangerous for yourself or other users of the engine. Carefully read the instructions given. You must read the safety rules, regulations and instructions before putting the engine into service.



DANGER

Means that extremely serious danger exists, that probably will cause death or permanent injury if the appropriate special steps are not taken.



WARNING

Means that danger exists that may cause injury or death if the appropriate special steps are not taken.



CAUTION

Reminds you of the safety steps or draws attention to dangerous practice that could cause injury to personnel or damage to the ship or its components.

The user will take all useful steps needed for operation and protection and, where necessary, request the advice of a professional.

Non-observance of safety instructions may entail:

Bodily danger, danger of polluting the environment (leaks of dangerous substances), hardware danger with risk of failure of the essential functions of the engine.

OBSERVE THE SAFETY RECOMMENDATIONS

- Comply with the caution and warning labels glued to the engine
- **Remove the ignition key and close the battery isolation switch before working on the engine or related equipment**
- Close the engine hood and put back protection guards before starting the engine
- Always keep the work zone around the engine clean
- Store flammable liquids outside the engine compartment
- Never use the engine after taking alcohol or medicines

WEAR PROTECTIVE CLOTHING

- To avoid bodily injury, keep away from rotating parts and do not wear loose clothing when working close to an operating engine
- Wear safety items such as goggles, gloves, etc... according to the circumstances and depending on requirements

FUELS AND LUBRICANTS

- Stop the engine before topping up with fuel and lubricants.
- Do not smoke close to the engine and keep any naked flames away when filling with fuel
- Wear gloves to detect a possible leakage.
- Hot oil can burn. Allow the engine to cool before checking the oil level, replacing the oil or the oil filter cartridge.
- Always use the oils and fuels recommended by NANNI DIESEL.

EXHAUST GAS PREVENTION

- Run the engine in a properly ventilated space away from people or animals. The accumulation of exhaust gas may be noxious.

PRESSURE

- Do not open oil or coolant caps when the engine is running or when it is hot. Release all pressure in circuits before removing the caps.
- Do not check for possible pressure leaks with your bare hands. Wear gloves. Discharged fluids under pressure may cause severe injury. If struck by a fluid jet, have the injury checked by a physician.

BATTERY

- An extremely explosive flammable and volatile detonating gas mixture forms when charging the battery. Never smoke or come close to the battery with a naked flame or an object producing sparks.
- Never short-circuit the terminals of the battery.
- The electrolyte in the battery is highly corrosive. Wear gloves and protective goggles.

ELECTRICAL WIRING

- Cut the engine contact and the battery isolation switch before starting any work on electrical equipment.
- Check the condition of electrical wiring and cables. A short circuit can cause a fire.

SCRAPPING FLUIDS

- The different fluids used to operate the engine constitute a danger to health. Fully read the instructions given on the packaging of these products.
- Observe the environmental protection rules related to scrapping of oil, fuel, coolant, filters and batteries.

1. GENERAL INFORMATION

Your NANNI DIESEL engine is a high quality NANNI INDUSTRIES designed and manufactured product. This engine is manufactured with the best materials according to precise specifications and strictly controlled manufacturing methods.

Your NANNI DIESEL engine is a reliable and long-lasting source of power for your boat.

The in-board installation of the engine of your boat is very important to ensure safe navigation and also respect of the environment.

NANNI INDUSTRIES engineers are amongst the most skilled worldwide. Their experience, knowledge of the sea, control of technical procedures and methods associated with the competence of MAN, KUBOTA and TOYOTA engineers ensure the best performance/reliability/investment ratio.



WARNING: *Your engine must be installed by a shipyard or a NANNI INDUSTRIES representative in compliance with the in-board installation instructions.*

This operating manual contains all information required to ensure correct operation of the engine.

NANNI INDUSTRIES is represented in more than 50 countries by its network of agents and vendors, and guarantees your safe navigation throughout the world. All services have been planned to meet your needs: spare parts, labor or just simply advice.

Do not hesitate to contact your NANNI DIESEL approved vendor.

Good sailing.

Carefully read this manual before using the engine.

Observe the safety instructions.



WARNING: *Correct operation of a marine engine is related to engine use adapted to the engine characteristics and its transmission system (type of boat, use rate and time).*

2. ENGINE IDENTIFICATION

The references indicated on the reverser and engine plates must be indicated in all correspondence, requests for information and orders for spare parts.

ENGINE TYPE
SERIES NUMBER
SPECIFICATION

IMPORTANT: *Write down the transmission system and engine model name and series number. Keep a copy of this information in a safe location.*

IDENTIFICATION OF MAIN COMPONENTS

1. Temperature exchanger
2. Coolant filling port
3. Block drain plug
4. Fresh water pump
5. Sea water pump
6. Alternator
7. Flexible suspension
8. Electrical connector
9. Starter
10. Oil filling port
11. Suction pipe for oil drainage pump
12. Air filter
13. Water injection exhaust elbow
14. Anode
15. Oil filter
16. Oil pressure transmitter
17. Gear reducer reverser
18. Injection pump
19. Electrical stop
20. Acceleration control
21. Air cooler
22. Turbo charger
23. Exchanger drain coupling
24. Turbo charger degassing valve
25. Turbo charger drainage valve
26. Condensation evacuation hole
27. Battery negative (-) cable connection
28. Fuel coolant (only for 4.390)
29. Fuel filter

3. PREPARATION BEFORE PUTTING INTO SERVICE

When the engine has been installed and before removing the protection devices blanking the different ports, clean all outer surfaces of the engine. These operations must be performed by the shipyard or an approved workshop.

GENERAL CHECK. (Refer to SILVERWAKE® warranty conditions.)

- Fill up the reverser and the engine oil tanks.
- Fill up the exchanger coolant tank. Degas at top point of turbo charger volute.
- Check belt tension.
- Check tightening of the different couplings and drainage caps (water and oil).
- Check tightening of electrical lugs, battery terminals, circuit breaker, extension connection, battery electrolyte level.
- Check acceleration control.
- Verify correct synchronization of the "accelerator and reverser" lever (mandatory in the case of a single level control). Clutching must be finished when acceleration starts.
- Perform a final check of attachments as well as a visual inspection of the entire marine power plant. If necessary touch up paintwork on the unit and accessories.



DANGER: Do not bring a flame or sparks close to the battery. An extremely explosive detonating gas forms during battery charging. Do not cause a short circuit.

The battery electrolyte is highly corrosive. If the acid is spilt on skin, immediately wash it with soapy water. If splashed into eyes, rinse generously with water and immediately consult a physician.

- Start with the positive terminal when connecting the cable to the battery.
- Start with the negative terminal when disconnecting the cable from the battery.



WARNING:

- Do not spill fuel or lubricant on the engine.
- The fluids used for engine operation are dangerous to health.
- Engine oil can damage the skin. Wear gloves.

NOTE: Modern diesel engines are precision made, requiring the use of high quality lubricants and fuel.

ENGINE AND GEAR BOX LUBRIFICATION

Engine

- Oil pump lubrication system, pressure adjusted by discharge valve
- Disposable cartridge oil filter

Transmission

Refer to separate specifications

Engine oil filling

Through the filling port located on the rocker cover by unscrewing the plug. Check the level with the gauge. Never exceed the maximum mark.

NOTE: Oil quality and quantity are indicated in the technical specification table.

FUEL CIRCUIT

Composition

Disposable cartridge main filter
Sea water/fuel coolant (4.390 TDI)
Injection pump
High-pressure injection pipes
Injectors

Fuel circuit bleeding

- Check the fuel level in the tank.
- Open the fuel valve, open the bleed screw located at the top part of the filter, pump using the built-in pump. Close the screw when the air bubbles disappear. If the entire injection circuit is unprimed, proceed as follows:
- Loosen injector No.1 supply pipe, rotate the engine with the starter until fuel is discharged. Tighten the nut and perform the same operation on the other injectors.
- Start the engine and check that there are no leaks



DANGER: *Do not smoke or bring a flame or sparks close to fuel.
Always wipe up spilled fuel.*

COOLING SYSTEM

The system comprises two different circuits: the closed coolant circuit and the seawater circuit.

Closed coolant circuit

This circuit comprises a pump controlled by the crankshaft by means of two V belts, a water temperature exchanger, an oil temperature exchanger integrated in the block and a thermostat.

Seawater circuit

The circuit comprises a pump, a fresh water-sea water temperature exchanger, a super-charger air coolant, a fuel coolant (for 4.390 TDI), a reverser oil exchanger and an exhaust elbow.

Coolant

Recommendations for first start-up:

- Check torque of the drain plug located under the turbo charger. Open the vent cap located on the top of the turbo charger volute.
- Prepare a permanent antifreeze mixture with 50% antifreeze and 50% fresh water. The quantity required is in the technical data table.

Pour the mixture in the filling port. Close the vent cap on the top of the turbo charger when the mixture is visible. Continue filling to maximum level. Future top-ups, if necessary, will be made with fresh water only, engine cold. Start the engine and top up the level. Verify that there are no leaks.

Every two years, at the beginning of the navigation season, fully drain the cooling system, clean with fresh water and fill again according to the previous instructions (Refer to SILVERWAKE guarantee conditions).



DANGER: *Top up with coolant, engine stopped and cold. Do not smoke or bring a flame close by.
Keep away from rotating devices when the engine is running.*



CAUTION: *Never add pure antifreeze. Use of additives or other types of coolant may cause the formation of insulating deposits and engine overheating.*

Hot water connection

An installation can be connected to the engine for on-board water heating by a derivation of the internal soft water circuit (refer to your NANNIDIESEL agent).

Seawater filter

A water filter must be adapted between the pump and the seawater intake. Verify and clean this filter on a regular basis.



CAUTION: *Before starting the engine, verify that the seawater intake is open, as dry operation for even a few seconds can damage the rotor of the water pump.
After cleaning the seawater filter, carefully close the cover to prevent the water pump from sucking in air.*

4. ENGINE OPERATION

STARTING



DANGERS - Correctly close the engine cover and fit all protection guards before starting the engine.

- Check the fuel level.
- Open the fuel supply valve.
- Open the seawater intake valve.
- Check the engine and reverser oil levels.
- Check the coolant level.
- Close the battery isolation switch
- **Make sure that the reverser control lever is in idle position**
- Turn the starting key clockwise to the "contact" position. The oil warning light, battery charging and pre-heating lights come on. The audible alarm can be heard. Pre-heating is active. Wait until the green light goes out, and then turn the ignition key clockwise until the engine starts. Immediately release when the engine has started.
- Check the indicators and other functions after engine starting.
- Immediately stop the engine if the alarm is given, if the temperature rises abnormally or if one or more indicators remain on.



CAUTION: Search for and eliminate the cause before restarting the engine!

- Allow the engine to run at idle speed for 2 or 3 minutes.
- Verify that the seawater effectively flows out via the exhaust.
- If the engine does not start first time, repeat the operation, waiting between 5 and 15 seconds with the contact cut between each attempt.

IMPORTANT:

Search for the cause if several unsuccessful attempts to start the engine have been made. Never continue to insist, as there is a risk of water returning into the engine via the exhaust system.



WARNING: Never cut the electrical circuit using the battery isolation switch when the engine is running. An operation of this type can damage the alternator.

ENGINE STOPPING

- return the lever to idle/dead point position
- Allow the engine to run at idle speed for several minutes to stabilize temperatures and turbo charger speed.
- **Never accelerate the engine before cutting the contact.**
- Turn the key to position "O" (vertical).
- Cut off the battery isolation switch, close the seawater intake valve and the fuel supply valve.

IMPORTANT: if it is necessary to tow the boat, stop the engine and close the sea water intake valve to avoid accidental filling of the engine with sea water.

TWIN ENGINE BOATS: When navigating with a single engine, close the seawater intake of the engine shut down. Do not forget to open it before restarting the engine.



CAUTION: Check the engine and the engine compartment to detect any possible leaks.

RUNNING IN – GUARANTEE INSPECTION OPERATIONS

Running in

During the first 20 hours of operation, it is recommended to use your engine carefully and only run at maximum rate for short periods of time.

Do not race the engine immediately after starting it without allowing it to warm up.

Guarantee inspection operations

All preventive maintenance operations, as well as related frequencies, are described in the guarantee logbook: SILVERWAKE®.

These inspection operations govern the validity of the guarantee. They must be carried out by an approved NANNI DIESEL representative.

New engines are guaranteed against any defective parts according to the methods specified in the **SILVERWAKE®** guarantee logbook handed over to the buyer when the engine is delivered.

5. SERVICING



DANGER: To prevent any bodily injury, shut down the engine and allow it to cool. Turn off the battery isolation switch before carrying out any work.

Observe the safety and environment protection instructions.

IMPORTANT – *These recommendations must be observed. Observance of the recommendations will extend the service life of the engine and govern normal coverage of the engine guarantee.*

- *Do not make any unauthorized modifications to the engine.*
- *Damage caused by the use of non-original spare parts are not covered by the guarantee.*
- *Servicing operations and repairs must be carried out by an approved NANNI DIESEL workshop.*

Servicing must be carried out once a year if the engine is used for a number of hours less than the given number. In this case, it is recommended to carry out servicing operations before wintering. The engine will then be protected by new, clean lubricating oil. This does not exclude the wintering operations quoted in the **SILVERWAKE** guarantee.

Valve clearance adjustment

These operations must be carried out by a specialized workshop (calibrated adjustment shims).

Frequency: according to the maintenance table.

- (refer to the values in the technical data table).

Replacing the water pump rotor

- Close the seawater intake valve.
- Remove the water pump cover.
- Extract the worn rotor using multi-grip pliers.
- Clean items kept.
- Install a new rotor.
- Reinstall the seawater pump cover using a new gasket.
- Open the seawater intake valve.
- Start the engine and check circuit sealing.

Electrical equipment

- Regularly check the alternator belt tension. Tension the belt between the pulleys (190 Nm using a DENSO controller).

 **DANGER** – Shut down the engine and turn off the battery isolation valve before performing any work on the electrical system

Battery

- Check the condition of battery elements once per season.
- The density of the electrolyte must be between 1.270 and 1.285.
- Check the electrolyte level periodically. The level must be 1cm above the plates. Only add distilled water if necessary.



DANGER – Never bring a flame close to the battery or check the battery with a spark, as the discharged gasses are flammable and explosive. The electrolyte in the battery is highly corrosive. If the acid touches the skin, immediately wash with soapy water. If splashed into the eyes, generously rinse with water and immediately consult a physician.

- Do not short circuit.

RECOMMENDATIONS

To ensure perfect operation of the alternator and the built-in regulator, **never**:

- Turn off the main battery isolation switch of the circuit when the engine is running (regulator can be destroyed).
- Reverse battery terminals. The terminals are respectively marked + (positive) and – (negative). The latter indicated terminal is connected to earth. Cable terminals, as well as cables, must be correctly secured.
- Change the circuit load when the engine is running.

Install a load distributor (Consult a NANNI DIESEL representative) to use several batteries.

When starting with a spare battery and jumper leads, proceed as follows:

- Disregard the main battery circuit, connect the spare battery to the main battery by connecting the + to the + and the – to the -. As soon as the engine starts, remove the jumper cables and do not turn off the main battery circuit.

You must disconnect the two battery cables when:

- you use a battery charger
- before any work on electrical equipment
- before performing welding work on a metal hull

Cooling circuit rinsing

Fresh water circuit

- Open the filling cap located on the exchanger.
- Open the draining plug under the turbo charger volute.
- Loosen the hollow screw coupling located under the exhaust manifold.
- Remove the block drainage plug located on the thermostat support.
- Drain old fluid from the temperature exchanger and the engine block.
- Fill the circuit with fresh water and allow the engine to run for a few minutes.
- Apply the filling/priming procedure described in the "Closed cooling circuit" paragraph.
- Drain the water and fill again with antifreeze/fresh water mixture.
- Top up the cooling circuit according to the specifications.

NOTE: If a hot water circuit is connected to the engine, fully drain it and refill taking into account the added quantity of mixture. Make sure that the air in the circuit is fully evacuated during filling.



WARNING: Pressurized fluid. Do not open the cap when the engine is hot. Allow the engine to cool and carefully open the cap.

Seawater circuit

- Close the seawater intake valve.
- Drain all seawater intake pipes, the filter, the seawater pump, the temperature exchanger and pipe by loosening the attachment collars.
- Drain the exhaust circuit, as a certain quantity of water remains in the bottom of the "water lock" exhaust silencer.

Clean the oil reverser and fuel, air, water temperature exchanger (if fitted).

Check the exchanger cores.

- Remove the covers.
- Remove the cores (except fuel exchanger), clean them with water and a non-corrosive commercially available product. Generously rinse.
- Replace o-rings and reinstall sub-assemblies



WARNING: *Corrosive products are a potential danger for health. Carefully read the instructions on product packaging.*

Replacing the fuel filter

The fuel filter is of the disposable type.

- Close the fuel valve.
- Coat the sealed new cartridge with clean oil
- Screw the new cartridge to the filter head, then tighten by hand $\frac{3}{4}$ of a turn (do not use tooling).
- Open the fuel valve.
- Bleed the circuit.
- Start the engine and check sealing.



CAUTION: *Always wipe up spilled fuel. Observe the environment protection instructions.*

Replacement of an injector

Remove:

- The injection pipe bar assembly
- The fuel return bar assembly
- The complete injector.
- Disassemble the injector.
- Replace the gasket and the injector nozzle.
- Check the calibration of the injector and atomization. Reinstall the components.



WARNING: *Never spray fuel onto the skin. Wear gloves.*

IMPORTANT: These works must be carried out by a NANNI DIESEL approved workshop. Injectors must be checked every 400 hours or every 2 years, according to the maintenance table and the SILVERWAKE® logbook.

Draining of engine crank case oil

The oil is extracted by a drain pump preferably with the engine warm.

- Pump until all the oil is extracted.
- Top up with fresh oil.
- Using the gauge, check that the level never exceeds the maximum level.



WARNING: *Hot oil can burn. Avoid any contact with the skin. Observe environment protection rules.*

Oil filter replacement

- The cartridge is of the disposable type.
- Connect a pipe to the sleeve of the filter head bowl and connect to a recipient.
- Unscrew the filter head cartridge.
- Coat the gasket of the cartridge with clean oil.
- Screw the new cartridge onto the filter head, then tighten by hand, $\frac{3}{4}$ of a turn (do not use tooling).
- Start the engine and check for leaks.
- Stop the engine and top up the oil level if necessary.



WARNING: *Hot oil can burn. Avoid any contact with the skin.
Observe environment protection rules.*

Reverser

Refer to detailed instructions in the reverser manual attached to the operating manual.

Reverser control system

Check the remote controls on a regular basis. The travel of the cable must be 35 mm either side of the dead point (O – A = O – B). The lever must be able to travel over its entire course.

Caution: lever positions



DANGER: *To avoid any bodily injury, do not start the engine without the air filter.*

<p>FICHE TECHNIQUE MOTEURS TYPE: T4.155 / 4.380 TDI / 4.390 TDI</p>	 <p>nannidiesel energy in blue</p>
<p style="text-align: center;">CHARACTERISTICS</p> <p>Number of cylinders: 4 Total displacement: 2982 Cm³ Bore-stroke: 96 x 103 mm Cylinder ratio: 19.7/1 Compression pressure: 3 MPa minimum Maximum difference per cylinder: 0.5 MPa Maximum speed under load: 3600 rpm Maximum unload speed: 4200 rpm Idle speed: 800 rpm Injection order: 1-3-4-2 Rotation direction: counter-clockwise (viewed from fly wheel) Cylinder No.1: timing side</p>	<p style="text-align: center;">LUBRICATION</p> <p>Idle oil pressure: 30kPa min. Normal oil pressure: 250 ~ 600 kPa Lubrication oil: API CD~CF15W40 (MOTUL TEKMA MEGA OR MOTUL MARINE 4T) Capacity: 6.4 – 7.7 liters, depending on inclination Reverser: depends on type Capacity: depends on type Oil: depends on type</p>
	<p style="text-align: center;">COOLING CIRCUIT</p> <p>Capacity: 15.5 liters Thermostat opening: 71°C</p>
<p style="text-align: center;">INJECTION</p> <p>Injectors: Denso Injection pump: Denso rotative Injection pressure: 15.2 MPa Injection setting: 0.46 – 0.02 mm</p>	<p style="text-align: center;">TIMING</p> <p>Cold valve clearance: Intake: 0.20 ~0.30 Exh: 0.25 ~0.35 Adjustment by shims, thickness 0.05 mm Piston protrusion: 0.08 ~0.33 mm</p>
<p style="text-align: center;">TURBOCHARGER</p> <p>Delivered pressure: T4.155: 80 ~ 90 kPa 4.380 TDI: 85 ~ 95 kPa 4.390 TDI: 93 ~ 103 kPa Axial clearance: 0.173 mm</p>	<p style="text-align: center;">RINGS</p> <p>Clearance at gap: - Top compression ring: 0.350 – 0.570 mm limit: 1.03 mm - compression ring: 0.40 – 0.60 mm limit: 1.10 mm - scraper: 0.20 – 0.50 mm limit: 0.87 mm</p>
<p style="text-align: center;">EXHAUST TEMPERATURE</p> <p>T4.155: 450 ~ 500°C , 4.380 TDI: 570 ~ 600°C, 4.390 TDI: 550~ 580°C</p>	<p style="text-align: center;">CYLINDER HEAD</p> <p>Flatness: < 0.15 mm</p>
	<p style="text-align: center;">SEA WATER PUMP</p> <p>Flow rate: 125 liters/min @ 3600 rpm</p>
<p style="text-align: center;">TIGHTENING TORQUE</p> <p>Cylinder head cover: 9 Nm Cylinder head screw: 39 Nm + 90° +90° Fly wheel screw: 145 Nm Connecting rod screw: 29 Nm + 90° Bearing screw: 49 Nm + 90° Cam shaft pulley: 98 Nm Crankshaft pulley: 363 Nm Injector carrier/cylinder head 37 Nm Injector nozzle/ cylinder head: 64 Nm Glow plugs: 13 Nm Injection pump shaft nut: 64 Nm Starter B+ terminal nut: 4 Nm</p>	<p style="text-align: center;">ELECTRICITY</p> <p>Glow plug resistance: 0.65Ω Recommended battery: 12V 100/110 Ah Alternator ND 14V 80A Rev sensor: 650 ~ 970Ω Rev counter pulse: 018.50 Starter: 12V 2.2kW</p>

1 kgf/m ≈ 10 Nm

1 bar ≈ 100 kPa

10 bar ≈ 1 MPa

RECOMMENDATIONS LUBRICATION AND COOLING

ENGINE OIL

API -CD~CF 15 W 40
Mineral

(MOTUL TEKMA MEGA OR MOTUL MARINE 4T)

COOLANT

50% PURE ANTIFREEZE
50% FRESH WATER

(MOTUL ANTIFREEZE)

MOTUL
MOTOR OIL

ALTERNATOR BELTS GLOW PLUGS

CHECKING THE ALTERNATOR DRIVE BELT CHECK THE ALTERNATOR DRIVE BELT

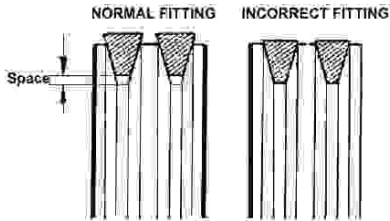

a) Check the drive belt and verify the amount of fraying, clogging or wear. Check that the top of the drive belt does not touch the bottom of the pulley groove. If one of the two drive belts is defective, replace both drive belts.

b) Check the sag in the drive belt by pressing the belt with a finger, at the locations indicated in the drawing , with a force of 98 N (10 kgf).

Drive belt sag:

New belt: 6 – 8 mm
Belt in service: 8 – 12 mm

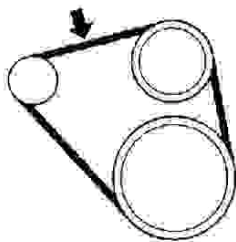

Readjust drive belt tension if the drive belt sag is not within the limits stipulated in the specifications.

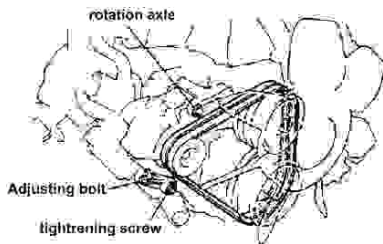

Special tool reference: 97031 2375

Reference

Measure the drive belt tension with special maintenance tool.

Drive belt tension:

New belt: 38 – 62 kgf
Belt in service: 20 – 40 kgf

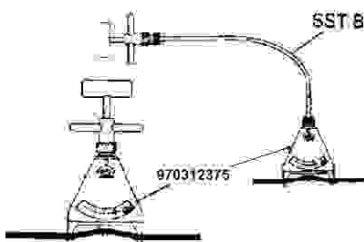

WARNING:

- "New belt" means a belt that is installed in an engine and that has rotated for less than 5 minutes.
- "Worn belt" means a belt that is rotated in an engine and that has turned for at least 5 minutes.
- After installing a new drive belt, run the engine for at least 5 minutes and verify the sag or the tension of the drive belt.

CHECKING GLOW PLUGS

REMARK: the resistance of glow plugs must be checked when the engine is fitted. Avoid removing and reinstalling glow plugs as far as possible.

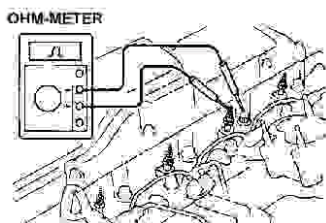

CHECK GLOW PLUGS

Use an ohmmeter to verify the continuity between the terminal and the earth of each glow plug.

Resistance (measured cold): approx 0.65Ω

Replace any glow plug with a resistance greater than 1.0Ω

CHECKING AND ADJUSTING VALVE CLEARANCE (ENGINE COLD)

1. REMOVE THE ROCKER COVER

Remove the ten assembly bolts, the two attachment nuts, the rocker cover and the gasket.

CYLINDER No.4 IS ON FLY WHEEL SIDE

2. PUT CYLINDER No.4 IN TOP DEAD POSITION

- Turn the crankshaft clockwise and make the notch in the timing cover coincide with the pulley timing indicator.
 - Check that the No.4 cylinder valve lifters include a clearance whereas the No.1 valve cylinder lifters are blocked.
- Otherwise, turn the crankshaft one complete turn (360°) to make the indicator mentioned above coincide.

3. MEASURE THE VALVE OPERATING CLEARANCE

- Only measure the clearance of the valves illustrated on the illustration opposite.
 - Only measure the clearance between the cam shaft and the valve lifter.
 - Record the clearance when it is not within the limits complying with specifications. This information will be used later to choose the set of thickness shims needed to correctly adjust the clearance

Valve clearance (cold):

Intake: 0.20 – 0.30 mm
Exhaust: 0.25 – 0.35 mm

- Turn the crankshaft pulley for one complete rotation (i.e. 360°) and make the advance setting marks coincide using the method indicated above

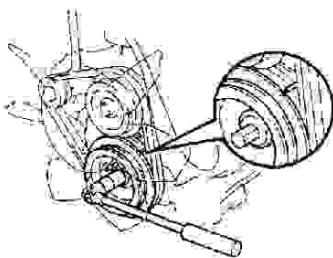
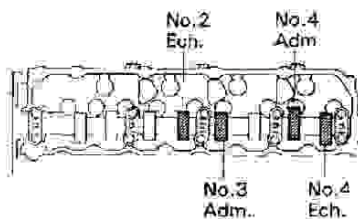
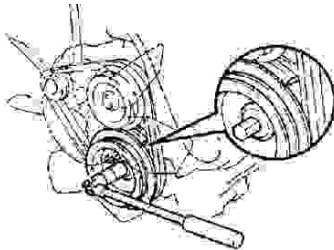
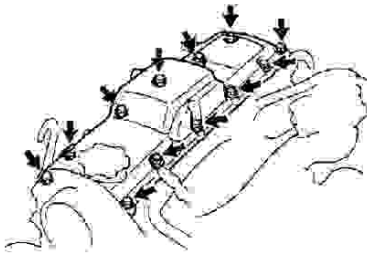

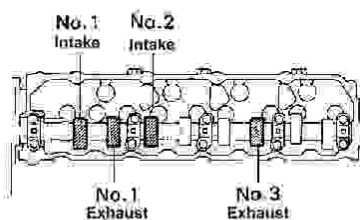

c) Only measure the clearance of the valves illustrated opposite. Measure the valve clearance .

d) Remove the thickness shim.

- Turn the crankshaft so as to position the peak of the cam shaft cam of the valve to adjust at the peak.

- Use special maintenance tool SST to compress the valve lifter.

ADVICE:

Before pressing the valve lifter, do not forget to correctly position the notch located on exhaust manifold side.

- Use a small screwdriver and a magnetic rod to remove the thickness shim.

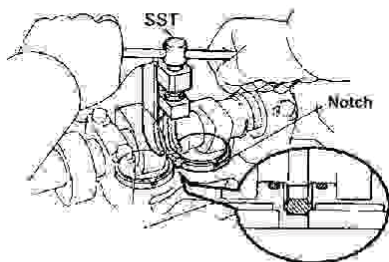

Special tool reference: 97031 2377

e) Select the appropriate size of the thickness shim to make the replacement in compliance with the indications in the formula of the following tables:

- Using a micrometer, measure the thickness of the removed shim
- Calculate the thickness of the new thickness shim to install so that the valve operating clearance is within the limits complying with specifications.

T Removed thickness shim thickness

A Recorded valve clearance

N Thickness of the new thickness shim to install

Intake: **N = T + (A - 0.25 mm)**

Exhaust: **N = T + (A - 0.30 mm)**

- Select a thickness shim of a thickness close to the calculated maximum valve clearance.

ADVICE:

There are seventeen sizes of thickness shims in thickness steps of 0.050 mm between 2.500 and 3.300 mm.

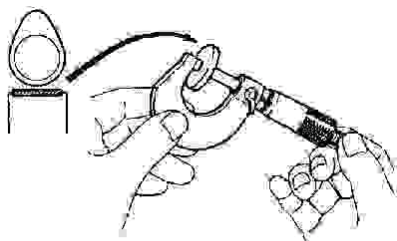
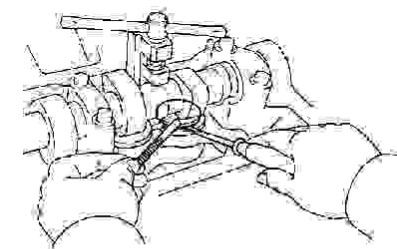

**Selection table for thickness shims
EXHAUST**

Thickness measured	Thickness shims installed																				
	mm (in.)																				
0.000 - 0.020 (0.0000 - 0.0008)																					
0.021 - 0.041 (0.0008 - 0.0016)																					
0.042 - 0.062 (0.0016 - 0.0024)																					
0.063 - 0.083 (0.0024 - 0.0031)																					
0.084 - 0.104 (0.0032 - 0.0039)																					
0.105 - 0.125 (0.0040 - 0.0047)																					
0.126 - 0.146 (0.0048 - 0.0056)																					
0.147 - 0.167 (0.0056 - 0.0063)																					
0.168 - 0.188 (0.0063 - 0.0071)																					
0.189 - 0.209 (0.0071 - 0.0079)																					
0.210 - 0.230 (0.0079 - 0.0087)																					
0.231 - 0.251 (0.0087 - 0.0094)																					
0.252 - 0.272 (0.0094 - 0.0102)																					
0.273 - 0.293 (0.0102 - 0.0110)																					
0.294 - 0.314 (0.0110 - 0.0118)																					
0.315 - 0.335 (0.0118 - 0.0126)																					
0.336 - 0.356 (0.0126 - 0.0134)																					
0.357 - 0.377 (0.0134 - 0.0142)																					
0.378 - 0.398 (0.0142 - 0.0150)																					
0.399 - 0.419 (0.0150 - 0.0158)																					
0.420 - 0.440 (0.0158 - 0.0166)																					
0.441 - 0.461 (0.0166 - 0.0174)																					
0.462 - 0.482 (0.0174 - 0.0182)																					
0.483 - 0.503 (0.0182 - 0.0190)																					
0.504 - 0.524 (0.0190 - 0.0198)																					
0.525 - 0.545 (0.0198 - 0.0206)																					
0.546 - 0.566 (0.0206 - 0.0214)																					
0.567 - 0.587 (0.0214 - 0.0222)																					
0.588 - 0.608 (0.0222 - 0.0230)																					
0.609 - 0.629 (0.0230 - 0.0238)																					
0.630 - 0.650 (0.0238 - 0.0246)																					
0.651 - 0.671 (0.0246 - 0.0254)																					
0.672 - 0.692 (0.0254 - 0.0262)																					
0.693 - 0.713 (0.0262 - 0.0270)																					
0.714 - 0.734 (0.0270 - 0.0278)																					
0.735 - 0.755 (0.0278 - 0.0286)																					
0.756 - 0.776 (0.0286 - 0.0294)																					
0.777 - 0.797 (0.0294 - 0.0302)																					
0.798 - 0.818 (0.0302 - 0.0310)																					
0.819 - 0.839 (0.0310 - 0.0318)																					
0.840 - 0.860 (0.0318 - 0.0326)																					
0.861 - 0.881 (0.0326 - 0.0334)																					
0.882 - 0.902 (0.0334 - 0.0342)																					
0.903 - 0.923 (0.0342 - 0.0350)																					
0.924 - 0.944 (0.0350 - 0.0358)																					
0.945 - 0.965 (0.0358 - 0.0366)																					
0.966 - 0.986 (0.0366 - 0.0374)																					
0.987 - 1.007 (0.0374 - 0.0382)																					
1.008 - 1.028 (0.0382 - 0.0390)																					
1.029 - 1.049 (0.0390 - 0.0398)																					
1.050 - 1.070 (0.0398 - 0.0406)																					
1.071 - 1.091 (0.0406 - 0.0414)																					
1.092 - 1.112 (0.0414 - 0.0422)																					
1.113 - 1.133 (0.0422 - 0.0430)																					
1.134 - 1.154 (0.0430 - 0.0438)																					
1.155 - 1.175 (0.0438 - 0.0446)																					
1.176 - 1.196 (0.0446 - 0.0454)																					
1.197 - 1.217 (0.0454 - 0.0462)																					
1.218 - 1.238 (0.0462 - 0.0470)																					
1.239 - 1.259 (0.0470 - 0.0478)																					
1.260 - 1.280 (0.0478 - 0.0486)																					
1.281 - 1.301 (0.0486 - 0.0494)																					
1.302 - 1.322 (0.0494 - 0.0502)																					
1.323 - 1.343 (0.0502 - 0.0510)																					
1.344 - 1.364 (0.0510 - 0.0518)																					
1.365 - 1.385 (0.0518 - 0.0526)																					
1.386 - 1.406 (0.0526 - 0.0534)																					
1.407 - 1.427 (0.0534 - 0.0542)																					
1.428 - 1.448 (0.0542 - 0.0550)																					
1.449 - 1.469 (0.0550 - 0.0558)																					
1.470 - 1.490 (0.0558 - 0.0566)																					
1.491 - 1.511 (0.0566 - 0.0574)																					
1.512 - 1.532 (0.0574 - 0.0582)																					
1.533 - 1.553 (0.0582 - 0.0590)																					
1.554 - 1.574 (0.0590 - 0.0598)																					
1.575 - 1.595 (0.0598 - 0.0606)																					
1.596 - 1.616 (0.0606 - 0.0614)																					
1.617 - 1.637 (0.0614 - 0.0622)																					
1.638 - 1.658 (0.0622 - 0.0630)																					
1.659 - 1.679 (0.0630 - 0.0638)																					
1.680 - 1.700 (0.0638 - 0.0646)																					
1.701 - 1.721 (0.0646 - 0.0654)																					
1.722 - 1.742 (0.0654 - 0.0662)																					
1.743 - 1.763 (0.0662 - 0.0670)																					
1.764 - 1.784 (0.0670 - 0.0678)																					
1.785 - 1.805 (0.0678 - 0.0686)																					
1.806 - 1.826 (0.0686 - 0.0694)																					
1.827 - 1.847 (0.0694 - 0.0702)																					
1.848 - 1.868 (0.0702 - 0.0710)																					
1.869 - 1.889 (0.0710 - 0.0718)																					
1.890 - 1.910 (0.0718 - 0.0726)																					
1.911 - 1.931 (0.0726 - 0.0734)																					
1.932 - 1.952 (0.0734 - 0.0742)																					
1.953 - 1.973 (0.0742 - 0.0750)																					
1.974 - 1.994 (0.0750 - 0.0758)																					
1.995 - 2.015 (0.0758 - 0.0766)																					
2.016 - 2.036 (0.0766 - 0.0774)																					
2.037 - 2.057 (0.0774 - 0.0782)																					
2.058 - 2.078 (0.0782 - 0.0790)																					
2.079 - 2.099 (0.0790 - 0.0798)																					
2.100 - 2.120 (0.0798 - 0.0806)																					

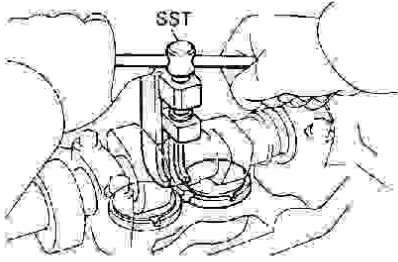

f) Install a new thickness shim.

- Install the new thickness shim on the valve lifter.
- Remove the special maintenance tool SST.

g) Verify the valve operating clearance

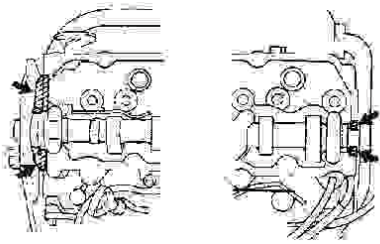

4. INSTALLATION OF THE ROCKER COVER

- a) Remove any signs of former gasket on the joint (FIPG)
- b) Coat the locations illustrated in the figure opposite with sealant.

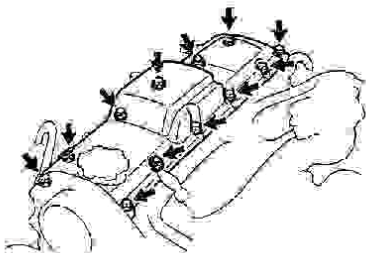

- c) Put the cylinder head gasket on the rocker cover.
- d) Install the rocker cover and secure with ten assembly bolts and two attachment nuts.

Recommended tightening torque: 9 N.m (90kgf.cm)

SETTING THE INJECTION ADVANCE

CHECKING AND SETTING THE INJECTION TIMING

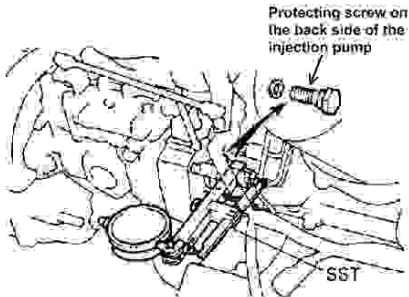

- 1 **Install the special maintenance tool SST and the dial gauge.**
 - a) Remove the bolt from the injection pump timing cap plug.
 - b) Install the special maintenance tool SST (plunger stroke measurement tool **reference: 970312378**) and the dial gauge on the hole for the timing cap plug.

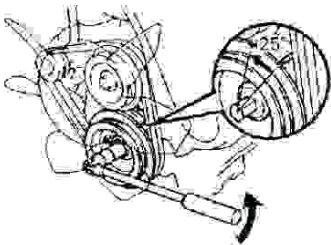

2. **Put the cylinder no. 1 or no. 4 piston between approximately 25° or more before dead top center of the compression stroke.**

Turn the crankshaft pulley counter-clockwise so that the notch in the pulley is at 25° or more from the timing cap indicator.

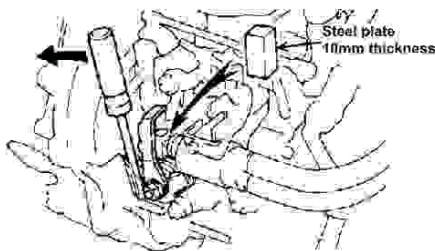

- 3 **Release the automatic cold start system.**
 - a) Use a screwdriver to turn the cold start lever counter-clockwise by approximately 20°.
 - b) Insert a metal plate (thickness 8.5 to 10 mm) between the cold start relay and the thermal wax plunger.

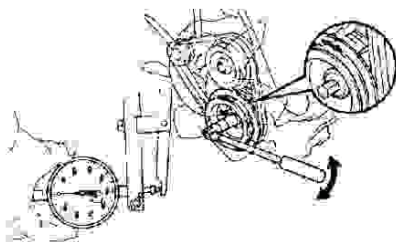

- 4 **Check the injection timing.**
 - a) Adjust the dial gauge to 0 mm.
 - b) Check again that the dial gauge is effectively on 0 mm while slightly turning the crankshaft pulley clockwise or counter-clockwise.

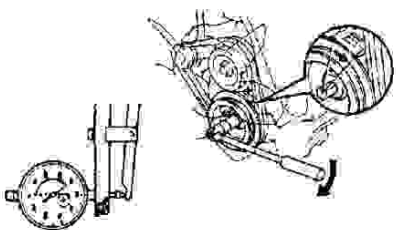

- c) Slowly rotate the crankshaft pulley clockwise until the notch of the pulley is aligned with the notch of the timing indicator.
- d) Measure the plunger stroke.

Plunger stroke:
0.46 mm

If the recorded value is not within the tolerances:

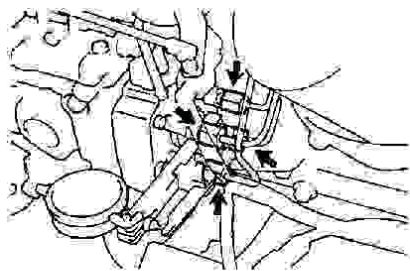

e) Loose the following assembly bolts and nuts.

- 1) The 4 attachment nuts of the injection pipe coupling on injection pump side.

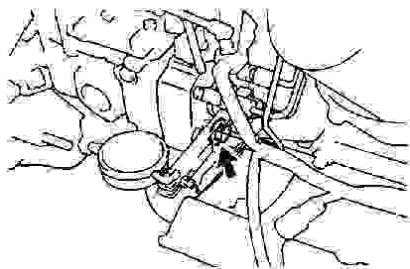

- 2) The bolts securing the injection pump to the injection pump spacer.

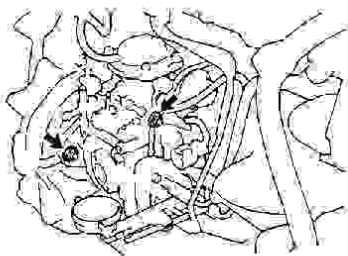

- 3) The 2 attachment nuts securing the injection pump to the timing gear casing.

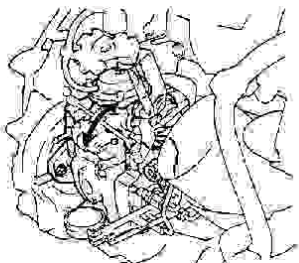

f) Adjust the plunger stroke by gradually inclining the injection pump body. If the plunger stroke is less than the limits stipulated in the specifications, incline the injection pump towards the engine.

If the plunger stroke is greater than the limits stipulated in the specifications, incline the injection pump away from the engine.

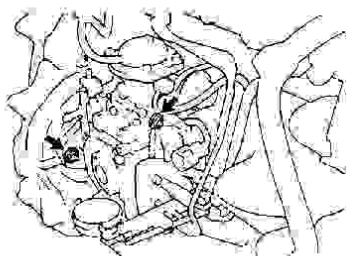

g) Re-tighten the following assembly bolts and nuts.

- 1) The 2 attachment nuts securing the injection pump to the timing gear casing.

**Recommended tightening torque:
21 .N.m (210 kgf.cm)**

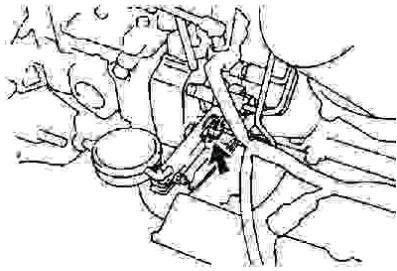

2) The bolts securing the injection pump on the injection pump space.

Recommended tightening torque: 32 N.m (330 kgf.cm)

* Verify the travel of the plunger piston

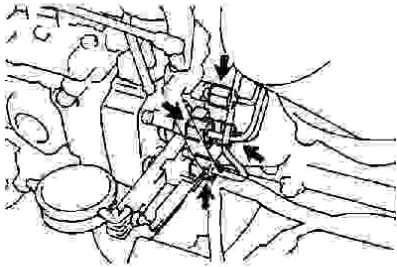

3) The four attachment nuts of the injection pipe coupling on injection pump side.

Recommended tightening torque: 15 N.m (150 kgf.cm)

REMOVE THE STEEL PLATE

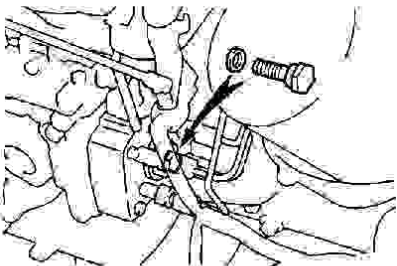

5 **REMOVE THE SPECIAL MAINTENANCE TOOL SST AND DIAL GAUGE**

- a) Remove the special maintenance tool SST and the dial gauge
- b) Install a new gasket and the timing head cap bolt.

Recommended tightening torque: 25.5 N.m (260 kgf.cm)

6 **START THE ENGINE AND VERIFY WHETHER THERE ARE ANY LEAKS**

To remove the injection pump it is necessary to use the pulley extractor

Reference: 970 312 374

REPLACING THE TIMING BELT **EVERY 1000 HOURS or 2 YEARS**

REMOVING THE TIMING BELT

(refer to the component part illustration for removal and reinstallation)

1) REMOVE THE TIMING BELT PROTECTION COVER

Remove the four assembly bolts, the sealing washers, the two fasteners, the timing belt protection cover and the gasket.

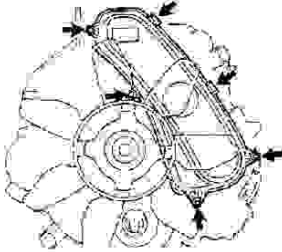

2) PUT No.4 CYLINDER IN TOP DEAD CENTER POSITION ON ITS COMPRESSION STROKE

Rotate the crankshaft fully clockwise to make the notches in No.1 and No.2 cam shaft pulleys coincide with the top dead center (TDC) timing marks.

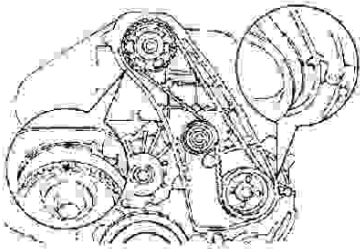

3) WHEN THE TIMING BELT IS RE-USED, MAKE A MARK ON THE TIMING BELT

ADVICE:

If the timing belt is re-used, make a mark in the rotation direction on the timing belt (engine rotation direction mark) then make timing alignment marks on the timing pulleys and the timing belt by working as shown in the figure opposite.

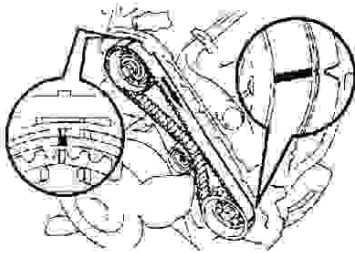

4) REMOVE THE TIMING BELT TENSIONER

Loosen alternately the two assembly bolts and then remove them and remove the timing belt tensioner.

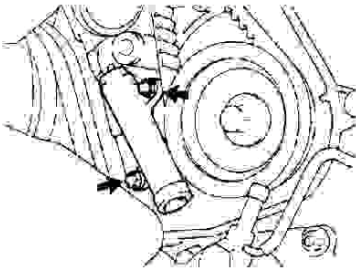

5) REMOVE THE TIMING BELT INTERMEDIATE PULLEY

Remove the assembly bolt using a 10 mm hex head wrench, intermediate timing belt pulley and the flat washer.

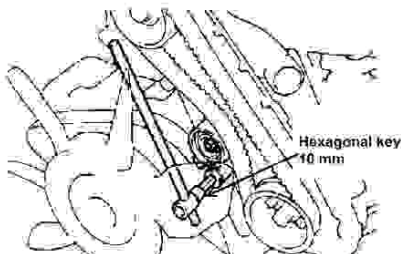

CHECK OF THE TIMING BELT EQUIPMENTS

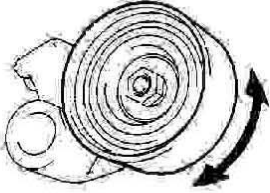

2) CHECK THE INTERMEDIATE PULLEY

Verify whether the timing belt intermediate pulley turns without any excessive friction. If necessary, replace the intermediate pulleys.

PRECAUTION:
REPLACE THE INTERMEDIATE PULLEY EACH TIME THE BELT IS REPLACED.

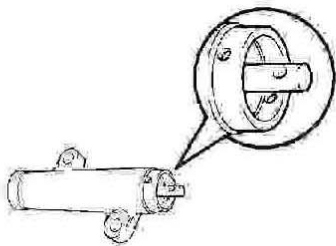

3) CHECK THE TIMING BELT TENSIONER

- a) Examine the timing belt tensioner and verify whether oil leaks occur.

ADVICE:

If a slight sign of oil is recorded on the lifter sealing gasket, the timing rod tensioner is in good condition. Replace the tightening belt tensioner if oil leaks are found.

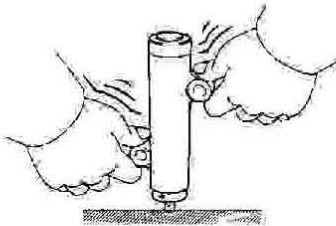

- b) Immobilize the timing belt tensioner with two hands and abruptly push the push rod against the ground or against the wall to verify that it does not enter. If the rod of the push rod enters, replace the tightening belt tensioner.

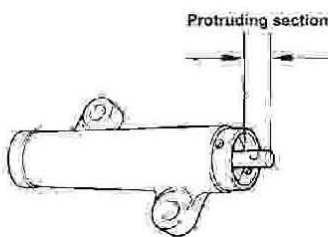

- c) Measure the protruding section of the box end push rod.

Protruding section: 8.1 - 8.9 mm (0.319 - 0.350 in;)

Replace the tensioner if the protruding section of the push rod is not within the specification limits.

PRECAUTION:
REPLACE THE TENSIONNER EACH TIME THE BELT IS REPLACED

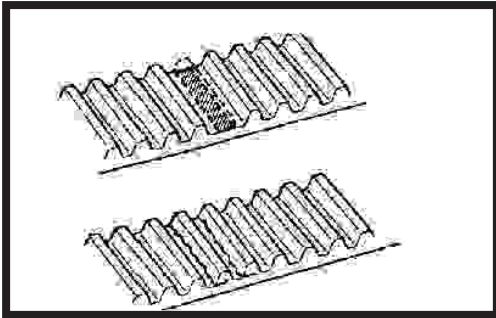

TEARING OFF OF 1 TOOTH
(Engine blocking...)

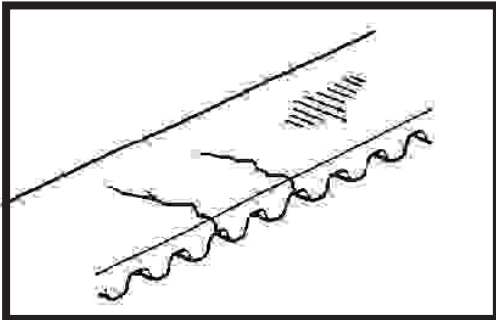

CRACKING
(Intermediate pulley deformation...)

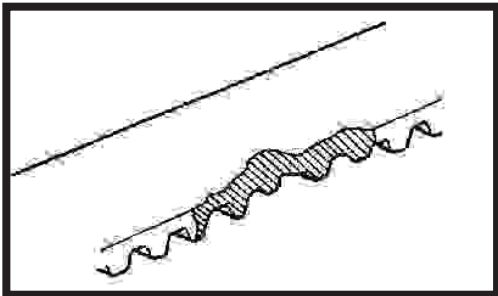

SIDE TORN OFF
(Pulley alignment...)

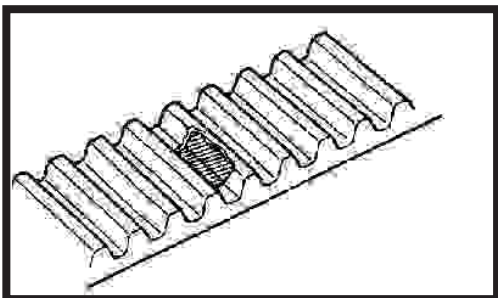

SURFACE TORN OFF
(Waste, impurities...)

SEVERAL EXAMPLES OF BELT DAMAGE REQUIRING IMMEDIATE REPLACEMENT
(Do not wait until it breaks)

REINSTALLATION OF TIMING BELT

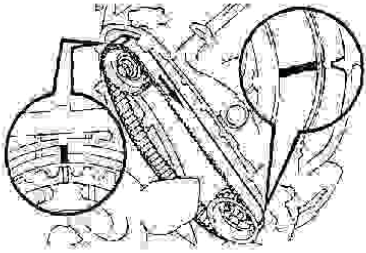

1) REINSTALL THE TIMING BELT

REMARK: The engine must be cold

ADVICE: If the timing belt is re-used, make the marks made during removal coincide, then reinstall the timing belt, taking care to point the arrow in the engine rotation direction

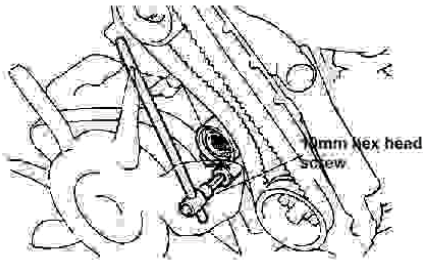

2) REINSTALL THE TIMING BELT INTERMEDIATE PULLEY

- Use a 10 mm hex head wrench, install the flat washer and the timing belt intermediate pulley with its pulley bolt.

Recommended tightening torque: 34 N.m (350 kgf.cm)

- Verify that the intermediate pulley moves normally. Otherwise verify the intermediate pulley and the washer.

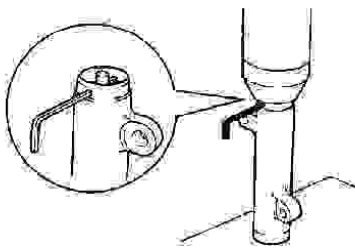

3) POSITION THE TIMING BELT TENSIONER

- Use a press and slightly compress the push rod under a pressure of 981 to 9.807 N (100 to 1.000 kgf).
- Make the holes in the push rod and the box coincide, insert a 1.5 mm allen key in the hole to secure the position of the push rod.
- Unblock the press.

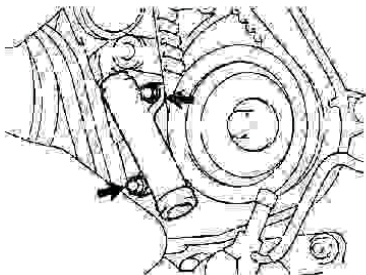

4) REINSTALL THE TIMING BELT TENSIONER

- Temporarily install the timing belt tensioner with the two assembly bolts while pushing the intermediate pulley towards the timing belt.
- Tighten the two assembly bolts to the recommended torque.

Recommended tightening torque: 13 N.m (130 kgf.cm)

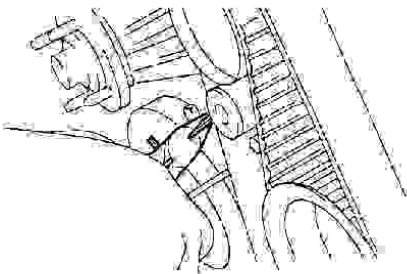

- Remove the 1.5 mm allen key from the tensioner.

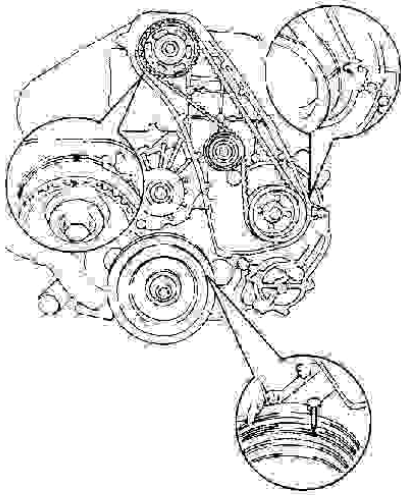

5) CHECK

Turn the crankshaft clockwise and verify that each pulley coincides with the alignment marks (top dead center mark) as illustrated opposite.
If the marks do not coincide, remove the timing belt and reinstall once more.

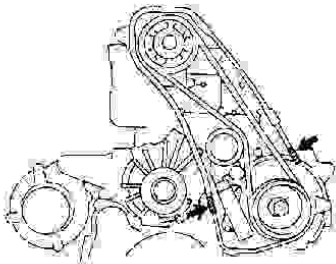

6) REINSTALL THE TIMING BELT PROTECTION COVER

- a) Remove signs of former sealant (FIGP).
- b) Coat the timing gear cover and cam shaft oil gasket attachment locations indicated in the figure opposite with sealant.

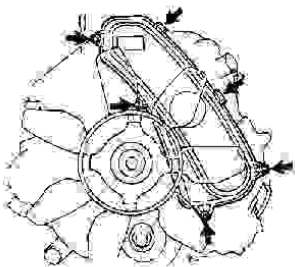

- c) Fit a new gasket on the timing belt protection cover.
- d) Reinstall the timing belt protection cover with four sealing washers and two fasteners.

COMPRESSION MEASUREMENT

CHECKING THE COMPRESSION

ADVICE:

Measure cylinder compression pressure when the engine efficiency is low, oil consumption excessive or fuel consumption uneconomical.

1) WARM THE ENGINE, THEN STOP IT

Allow the engine to heat up to its normal operating temperature.

2) DISCONNECT THE INJECTION PUMP WIRING COUPLING UNIT (POWER SUPPLY CUTOFF CONTROL SOLENOID)

3) REMOVE THE INJECTORS

4) MEASURE THE COMPRESSION PRESSURE OF EACH CYLINDER

- a) Install the accessory on the injector port.
- b) Connect the compression meter to the accessory.
- c) Measure the compression pressure while turning the engine over with the starter.

ADVICE:

A fully charge battery must always be used in order to be sure that the engine is rotated at least 250 rpm.

- d) Repeat operations a. to c. on each cylinder.

REMARK: These measurements must be made in the shortest possible period of time.

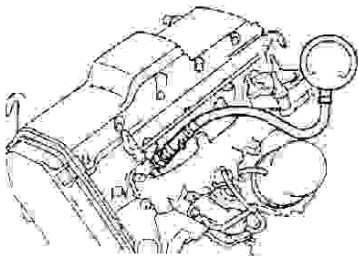
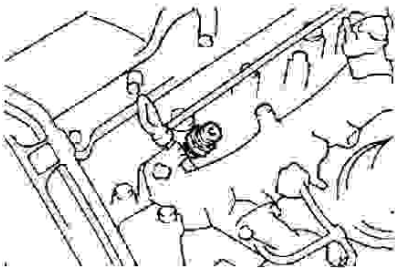
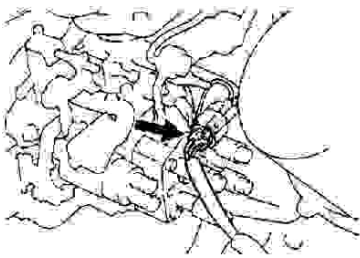

Compression pressure:
3.040 kPa (31.0 kgf/cm²) or more

Minimum pressure:
1.961 kPa (20.0 kgf/cm²)

Pressure difference between cylinders:
Less than or equal to 490 kPa (5.0 kgf/cm²)

e) If the compression pressure of one or more cylinders is less than that of the other cylinders, pour a small amount of engine oil in the injection port and repeat checking operations **a.** to **c.** on the cylinder where the pressure is low

- If adding engine oil in the cylinders makes it possible to increase the compression pressure, it is probable that the failure is due to wear or damage to rings and/or cylinder bore.
- On the other hand, if the compression pressure does not change, it is probable that this is due to a stuck valve, a poor seat or a broken gasket.

5) REINSTALL THE INJECTORS

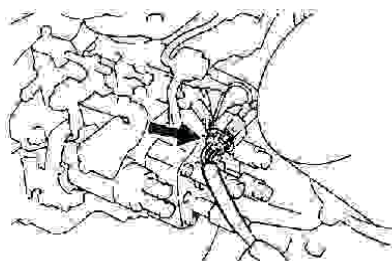

6) RECONNECT THE INJECTION PUMP WIRING COUPLING UNIT (POWER SUPPLY CUTOFF CONTROL SOLENOID).

7) START THE ENGINE AND VERIFY WHETHER FUEL LEAKS OCCUR.

PISTON PROTRUSION SELECTION OF THE CYLINDER HEAD GASKET REINSTALLATION AND TIGHTENING OF THE CYLINDER HEAD

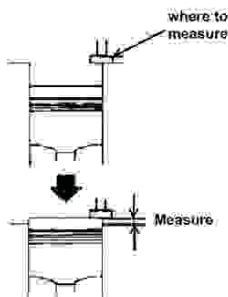
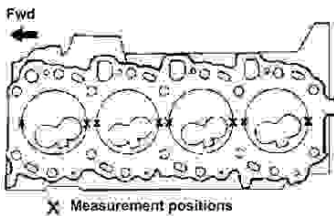
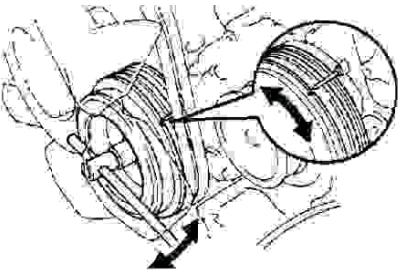
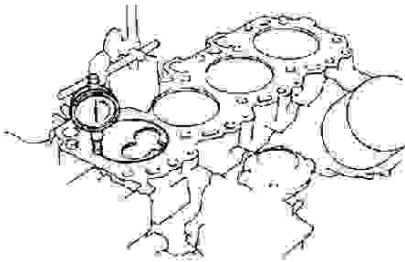

1) CHECK THE PROTRUDING PART OF THE PISTON AND CHOOSE AN APPROPRIATE CYLINDER HEAD JOINT

A) Check the protruding part of the piston of each cylinder.

- a) Carefully clean the cylinder block assembly surface with a grease remover.
- b) Position the piston cylinder so as to measure a location just before top dead center pressure
- c) Install a dial gauge on the cylinder block and adjust the dial gauge to 0 mm.

WARNING:

- Use the dial gauge as shown on the figure opposite.
- Verify that the sensor is perpendicular to the surface of the cylinder block gasket and piston head.

- d) Find the position corresponding to the greatest percentage of piston head protrusion by slowly rotating the crankshaft in a clockwise direction or in a counter-clockwise direction.
- e) The measurement must be made at two different locations for each cylinder, proceeding as illustrated in the figure opposite.
- f) Using the piston protrusion percentage measurements made on each cylinder, select the average value of two measurements for each cylinder.

Protrusion:

0.08 – 0.33 mm (When the piston-connecting rod is removed)

If the piston head protrusion value is not within the limits recommended by the specifications, remove the piston-connecting rod assembly and reinstall it.

B) Select a new cylinder head gasket.

WARNING:

There are 5 types of cylinder head gaskets (hole No.1 to 5) which are installed in the factory but only 3 types as procurement parts (hole No. "1", "3", and "5") so that when replacing a cylinder head gasket, the choice of the gasket must be from amongst these 3 types proposed.

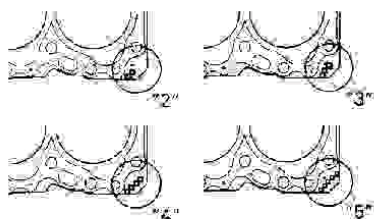
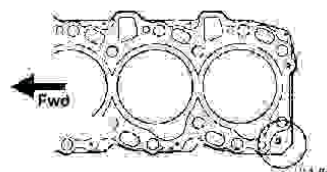

Thickness of the cylinder head gasket installed:

Hole No. "1": 0.80 – 0.90 mm

Hole No. "3": 0.90 – 1.00 mm

Hole No. "5": 1.00 – 1.10 mm

Using the piston protrusion percentage measurements made on each of the cylinders, select the most appropriate value and then choose the appropriate cylinder head gasket in compliance with the information given in the table below.

Piston protrusion in mm	Gasket size
0.08 – 0.12	Use gasket No. "1"
0.13 – 0.22	Use gasket No. "3"
0.23 – 0.33	Use gasket No. "5"

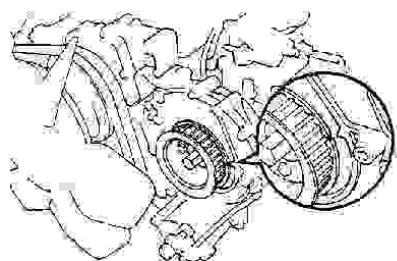

2) PUT CYLINDER No.4 IN TOP DEAD POSITION ON ITS COMPRESSION STROKE

Rotate the cylinder head pulley to the position of top dead center mark of the timing casing cover in front of the No.2cam shaft timing pulley.

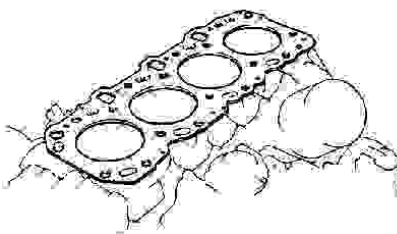

3) REINSTALL THE CYLINDER HEAD

A) Install the cylinder head on the cylinder block.

- a) Install a new cylinder head gasket on the cylinder block and on its positioning studs.

REMARK: Pay attention to the recommended assembly direction.

- b) Reinstall the cylinder head on the new cylinder head gasket.

B) Reinstall cylinder head bolts.

WARNING:

- Cylinder bolts must be tightened gradually in three step (step (b), (d) and (e)).
- Any broken or deformed cylinder head bolt must be replaced.

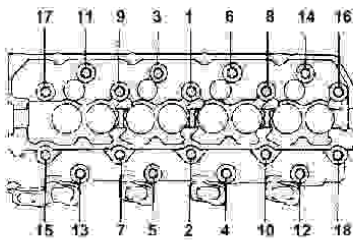
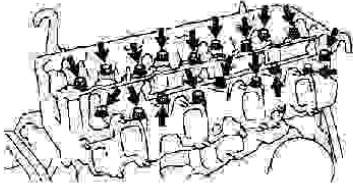

- a) Put a drop of engine oil on bolt threads and under bolt heads before reinstalling them.
- b) Reinstall and uniformly tighten these eighteen cylinder head bolts in several steps in compliance with the order indicated in the figure opposite.

Recommended tightening torque: 39 N.m (400 kgf.cm)

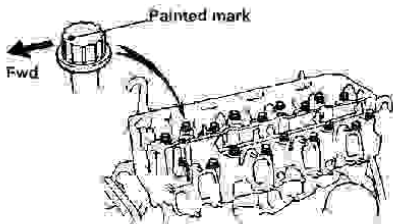

- c) Identify the front of the cylinder head bolt with paint.

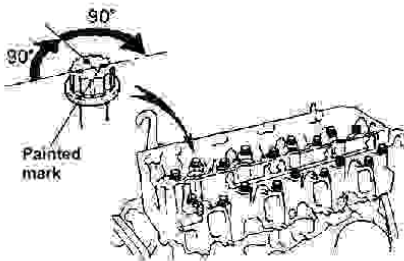

- d) Tighten cylinder head bolts 90° in the numbered order indicated in the illustration opposite.
- e) Tighten cylinder head bolts 90° more.
- f) Verify that the painted mark is now facing towards the rear.

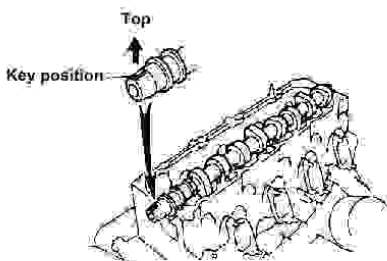

4. REINSTALL THE CAM SHAFT

- a) Install the cam shaft on the cylinder taking care to direct the key groove upwards.

b) Reinstall the five bearing caps at their respective locations.

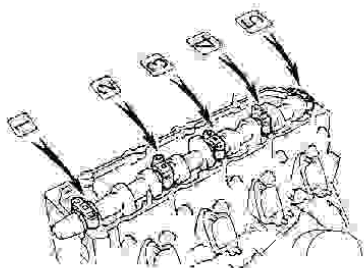

c) Reinstall and evenly tighten the ten bearing cap bolts to the recommended torque, in the tightening order indicated opposite.

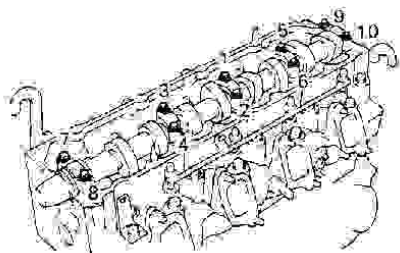

Recommended tightening torque: 18 N.m (185 kgf.cm)

5. REINSTALL THE CAM SHAFT OIL GASKET RETAINER

a) Carefully remove all signs of former sealant (FIPG) from mating surfaces and take care not to dirty the assembly surfaces of the cylinder head and cam shaft oil gasket retainer with oil.

- Carefully remove all signs of former sealant (FIPG) from gasket application surfaces and from the sealing groove using a razor blade and scraper designed for this purpose.
- Carefully clean all removed parts to ensure that no signs of sealant remain.
- Clean the two sealing surfaces with a residue-free solvent

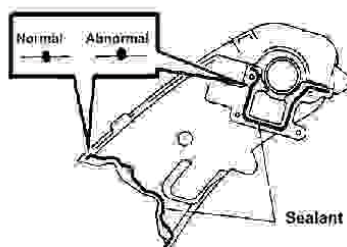

b) Apply a bead of sealant to the timing casing cover as shown in the figure opposite.

- Install a nozzle on the tube already cut to make a 2 to 3 mm opening.

WARNING:

Make sure not to apply an excessive quantity of the product on the assembly surface

CHECKING THE COOLING SYSTEM COMPONENTS

FREQUENCY: REFER TO MAINTENANCE PLAN

HARDWARE IN DIRECT CONTACT WITH SEA WATER MUST BE MADE OF A4.70 STAINLESS STEEL

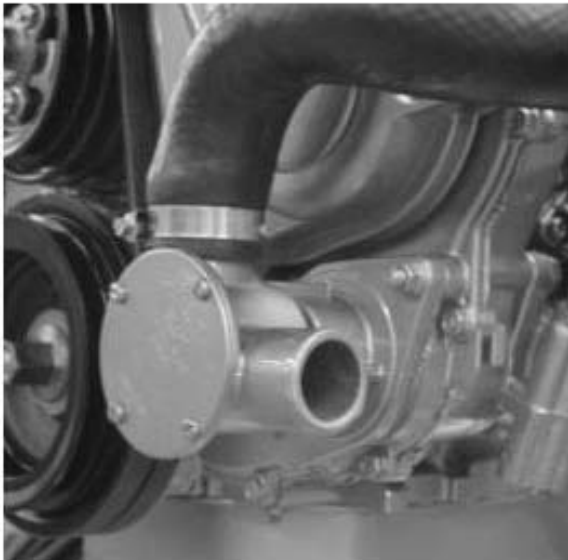

SEA WATER PUMP:

Replacing the rotor and cover gasket

THERMOSTAT:

Opening temperature check. replacement

OPENING:
71°C

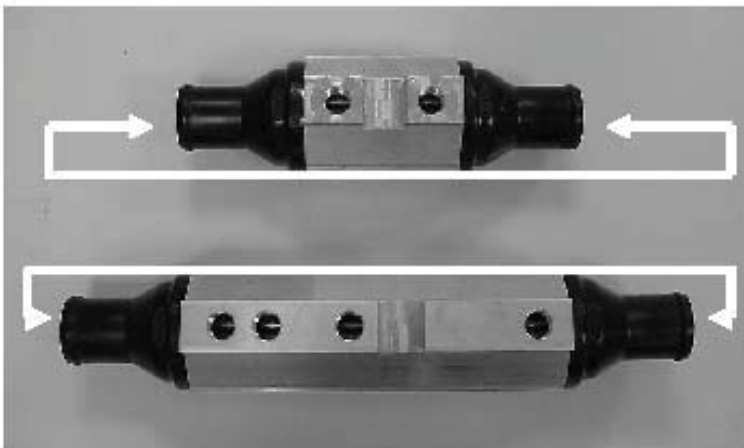
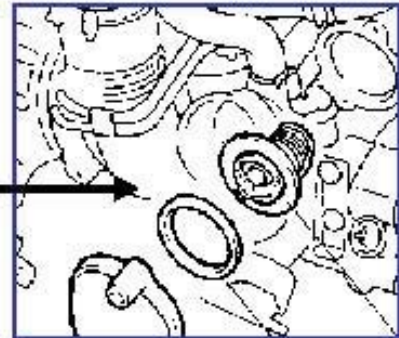

COOLERS:

for gearbox, stern drive oil and Fuel
(only 4.390TDI)

Check the core and internal hardware
(1 per cover, A4.70 stainless steel screw)

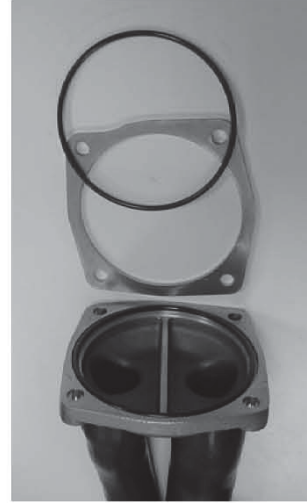
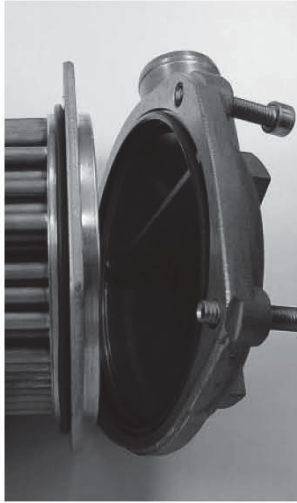
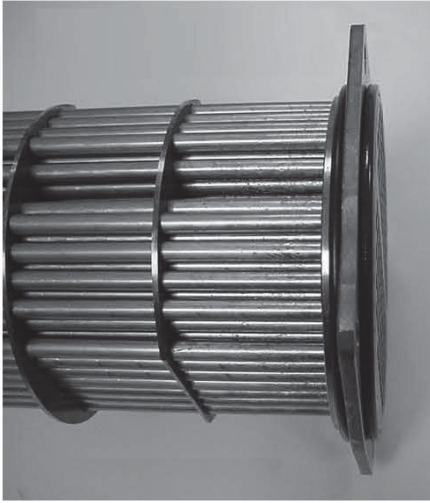

EXCHANGER:

Clean the core and replace o-rings

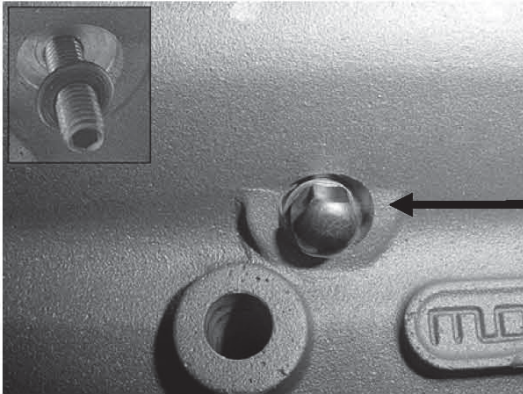

CAUTION:

Core securing screw in exchanger body.

INTERCOOLER: Clean the core and replace o-rings

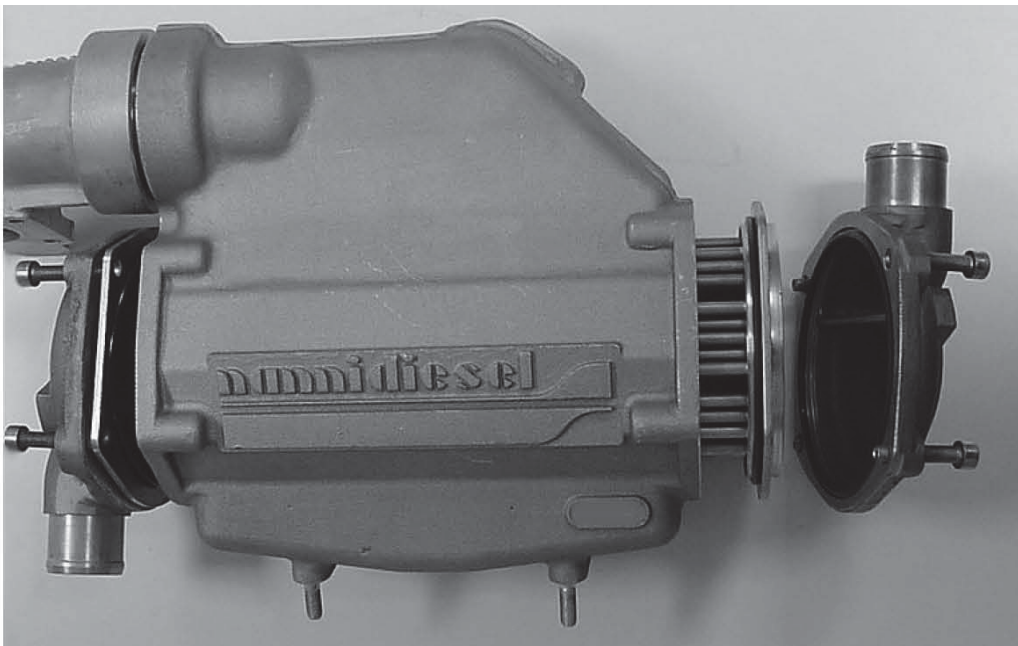

ANODE ON EXHAUST ELBOW: Check and replace

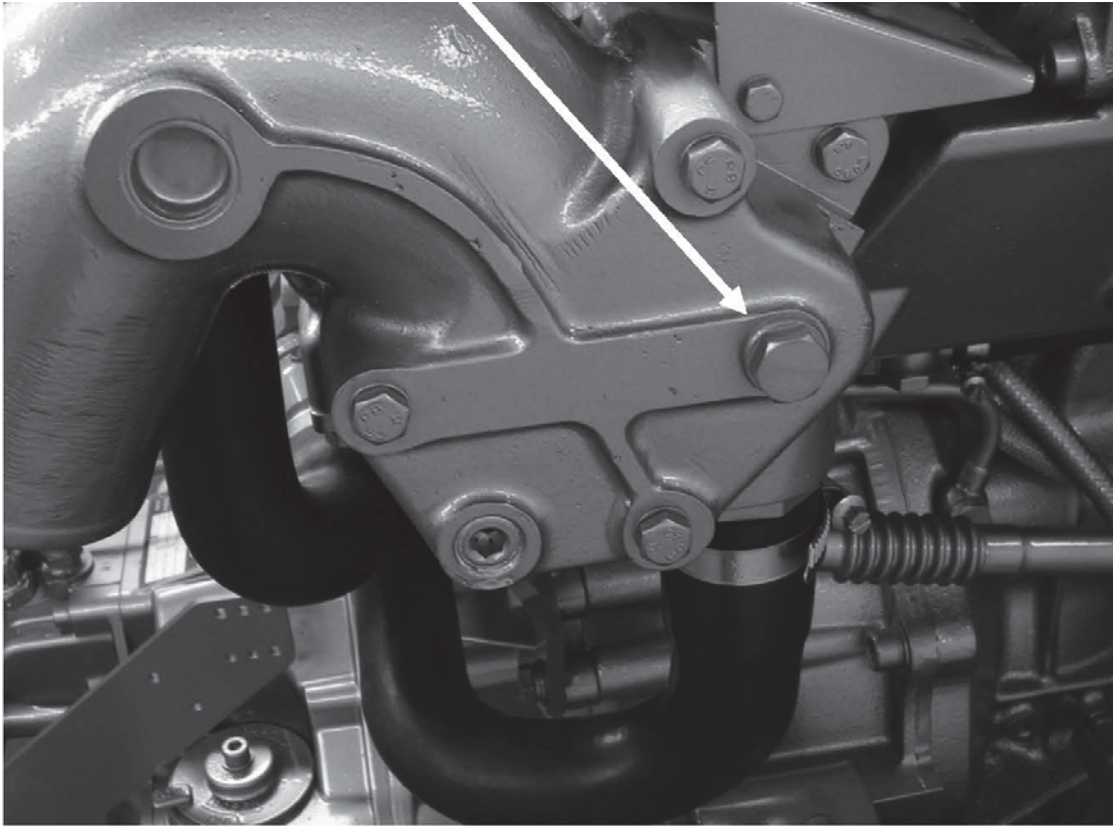

COOLANT:

50% PURE ANTIFREEZE, 50% FRESH WATER

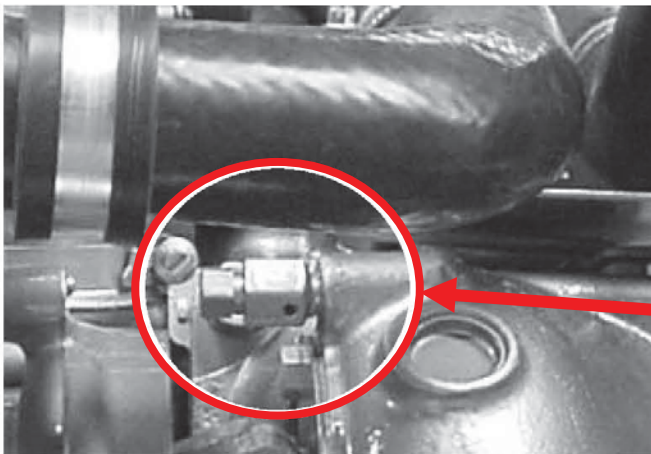

IMPORTANT:

**BLEED THE FRESH WATER
CIRCUIT ON THE TURBO
CHARGER**

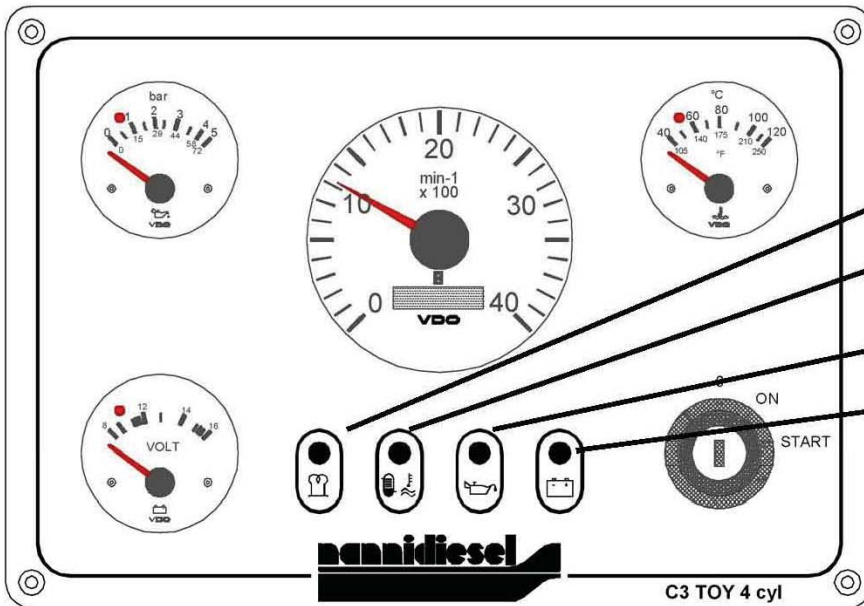

INDICATORS:

- Pre-heating
- Water in fuel and water alarm
- Oil alarm
- Battery charging

PANEL C3: rectangular connector

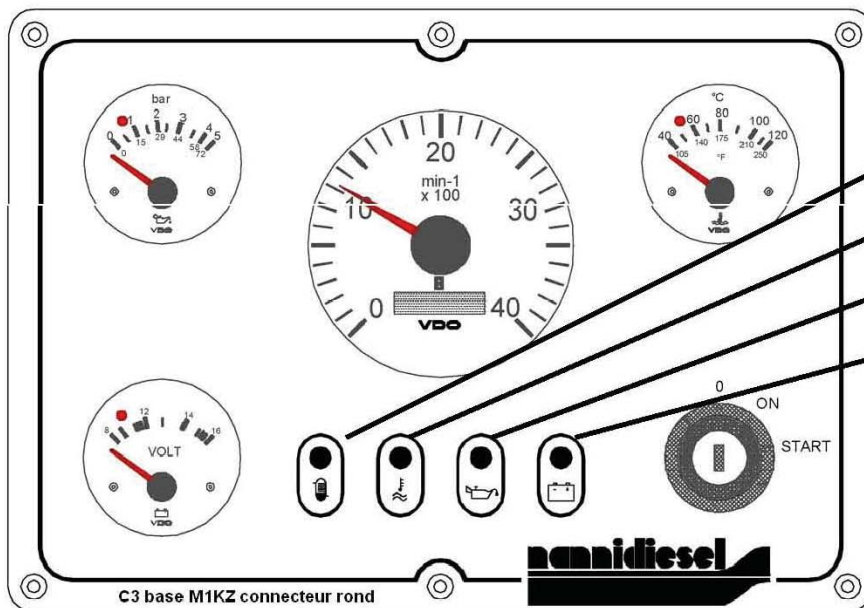

INDICATORS:

- Water in fuel
- Water alarm
- Oil alarm
- Battery charging

PANEL C3: round connector

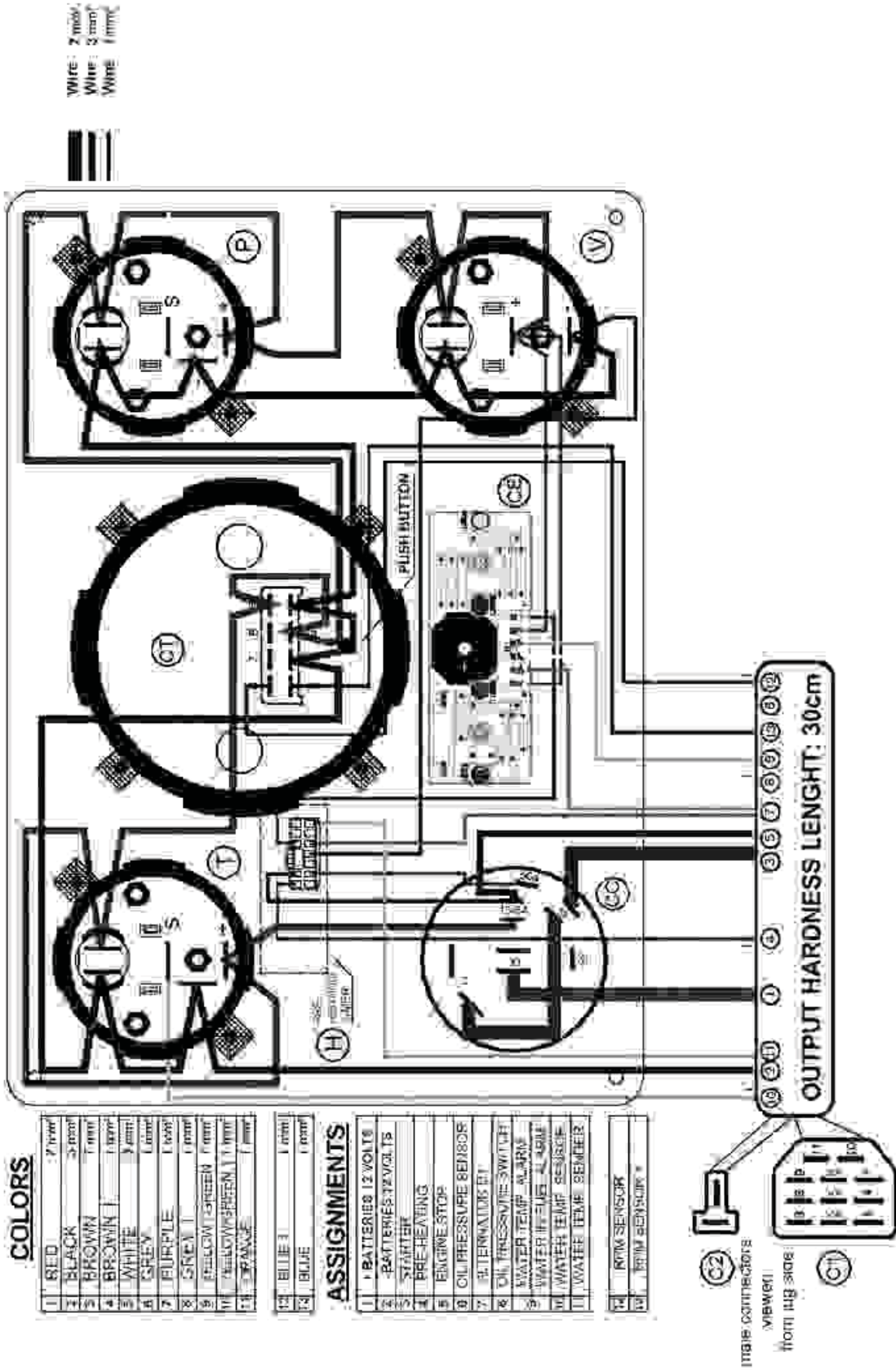

TOYOTA 4 cylinder BASE PANEL CONNECTORS

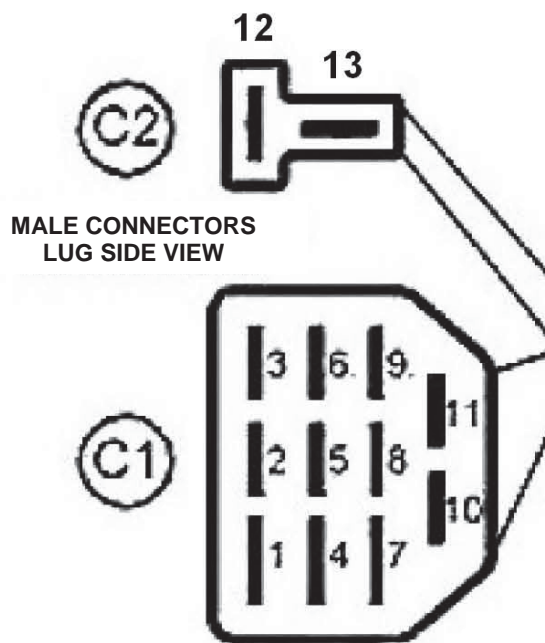

4 CYLINDERS TOYOTA SQUARE CONNECTOR 11 terminals + 2 terminals		
TERMINAL No.	WIRE COLOUR	FUNCTION
1	RED	BATTERY +
2	BLACK	BATTERY -
3	BROWN	STARTER
4	BROWN 1	PRE-HEATING
5	WHITE	STOP
6	GREY	OIL PRESSURE SWITCH
7	PURPLE	ALTERNATOR LOAD
8	GREY 1	OIL ALARM
9	YELLOW/GREEN	WATER + WATER IN FUEL DETECTOR ALARM
10	YELLOW/GREEN 1	WATER TEMP SWITCH
11	ORANGE	WATER TEMP to RELAY
12	BLUE	- REV COUNTER
13	BLUE	+ REV COUNTER

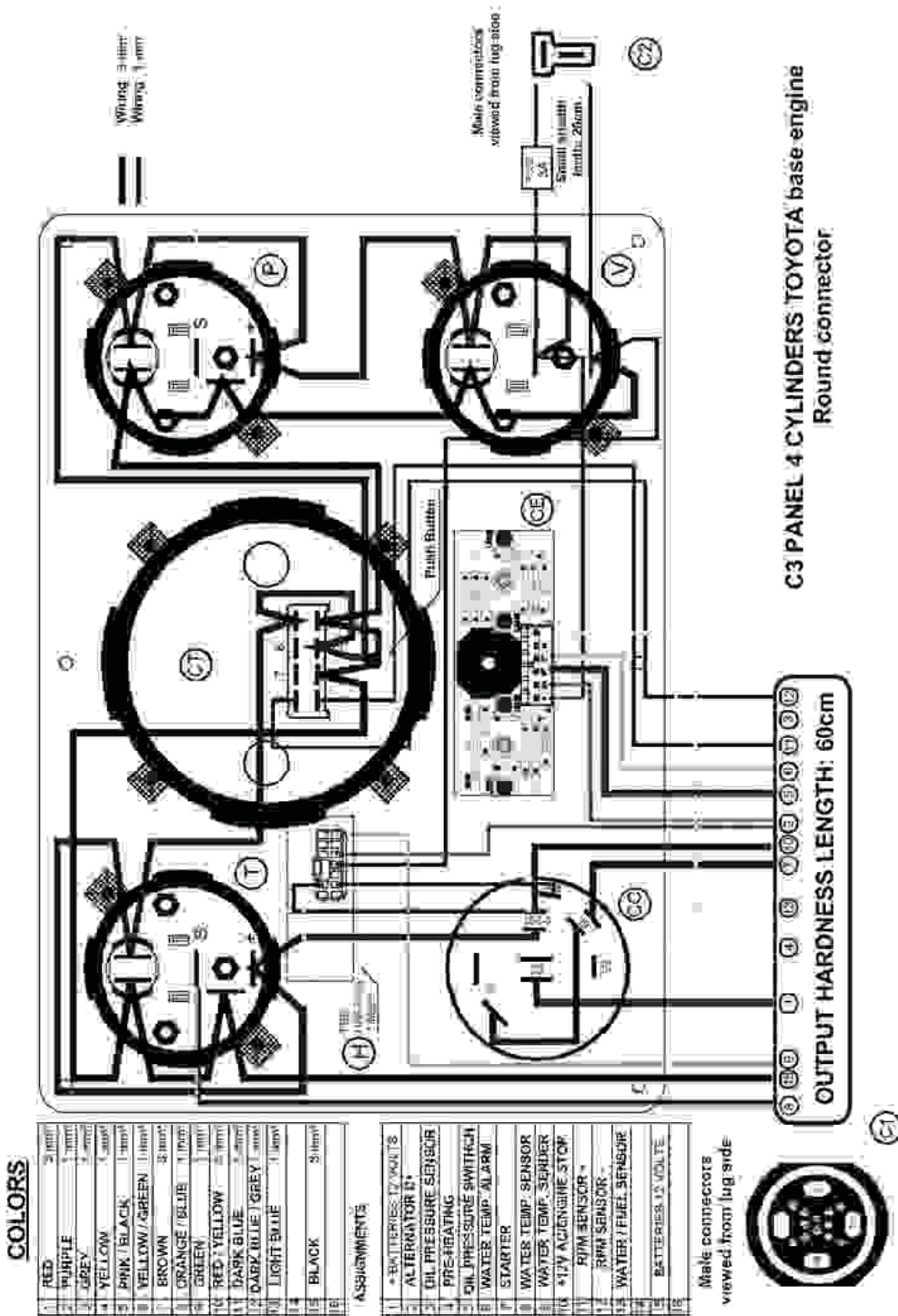

**ENGINE HARDNESS CONNECTOR
ROUND MODEL**

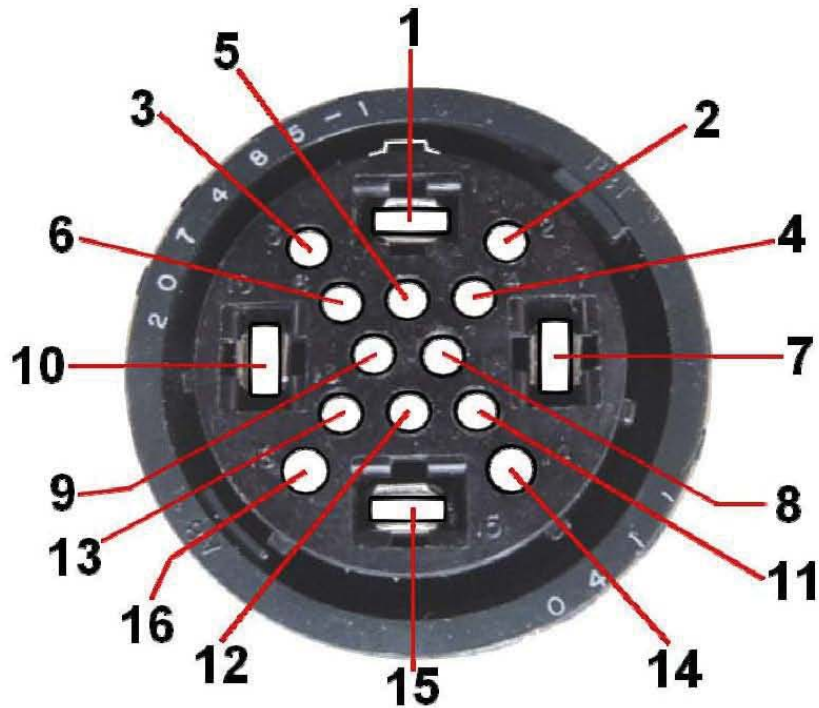

1	RED	BATTERY +
2	PURPLE	CHARGE INDICATOR
3	GREY	OIL PRESSURE PROBE
4	YELLOW	PRE-HEATING
5	PINK / BLACK	OIL ALARM
6	YELLOW / GREEN	WATER ALARM
7	BROWN	STARTING
8	ORANGE / BLUE	WATER TEMPERATURE PROBE
9	GREEN	PRE-HEATING TIMEOUT PROBE
10	WHITE	ENGINE STOP
11	BLUE	+ REV COUNTER
12	BLUE / GREY	- REV COUNTER
13	LIGHT BLUE	WATER / FUEL INDICATOR
14	XXXXXXXXXXXXXX	NOT USED
15	BLACK	EARTH
16	XXXXXXXXXXXXXX	NOT USED

ELECTRICAL DRAWING

Rectangular connector

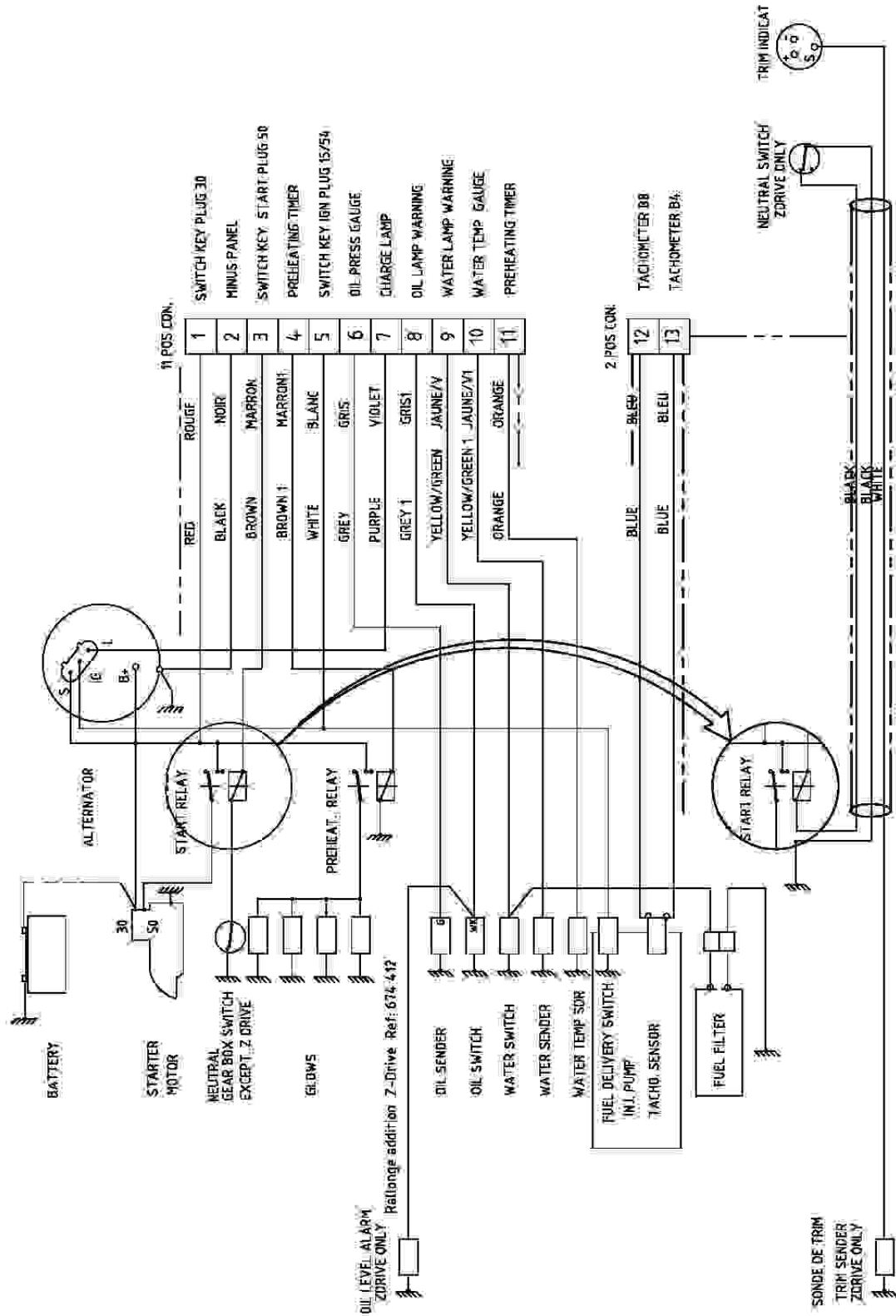

Extension stern drive hardness ref: 674 409
 Extension stern drive hardness ref: 674 410
 Extension stern drive hardness ref: 674 411

LIST OF ESSENTIAL SPECIAL TOOLS

- Alternator belt tension controller
 - 970 312 375

- Valve adjustment tool:
 - 970 312 377

- Injection pump dial gauge support
 - 970 312 378

- Pulley / pinion extractor box (usable on all NANNI models)
 - 970 312 374

- Valve spring compressor
 - 970 312 372

- Combustion chamber extractor
 - 970 312 373

- Crankshaft lip seal installation tool:
 - 970 312 376

CONTENTS EXPLODED VIEW OF THE 4 CYLINDERS TOYOTA base ENGINE

TIMING BELT
TIMING CASING
TIMING PINIONS
CYLINDER HEAD
CYLINDER BLOCK
GLOW PLUGS
INJECTORS
INJECTION PUMP
THERMOSTAT
FRESH WATER PUMP
OIL PUMP
OIL RADIATOR
OIL INJECTORS
TURBO CHARGER

TIMING BELT

COMPONENT PARTS REMOVAL AND REINSTALLATION

Cylinder Head cover

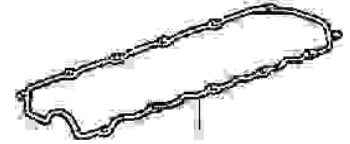
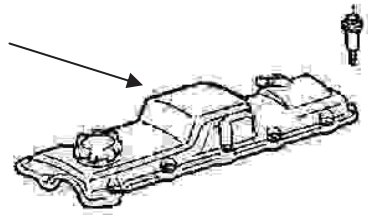

Gasket

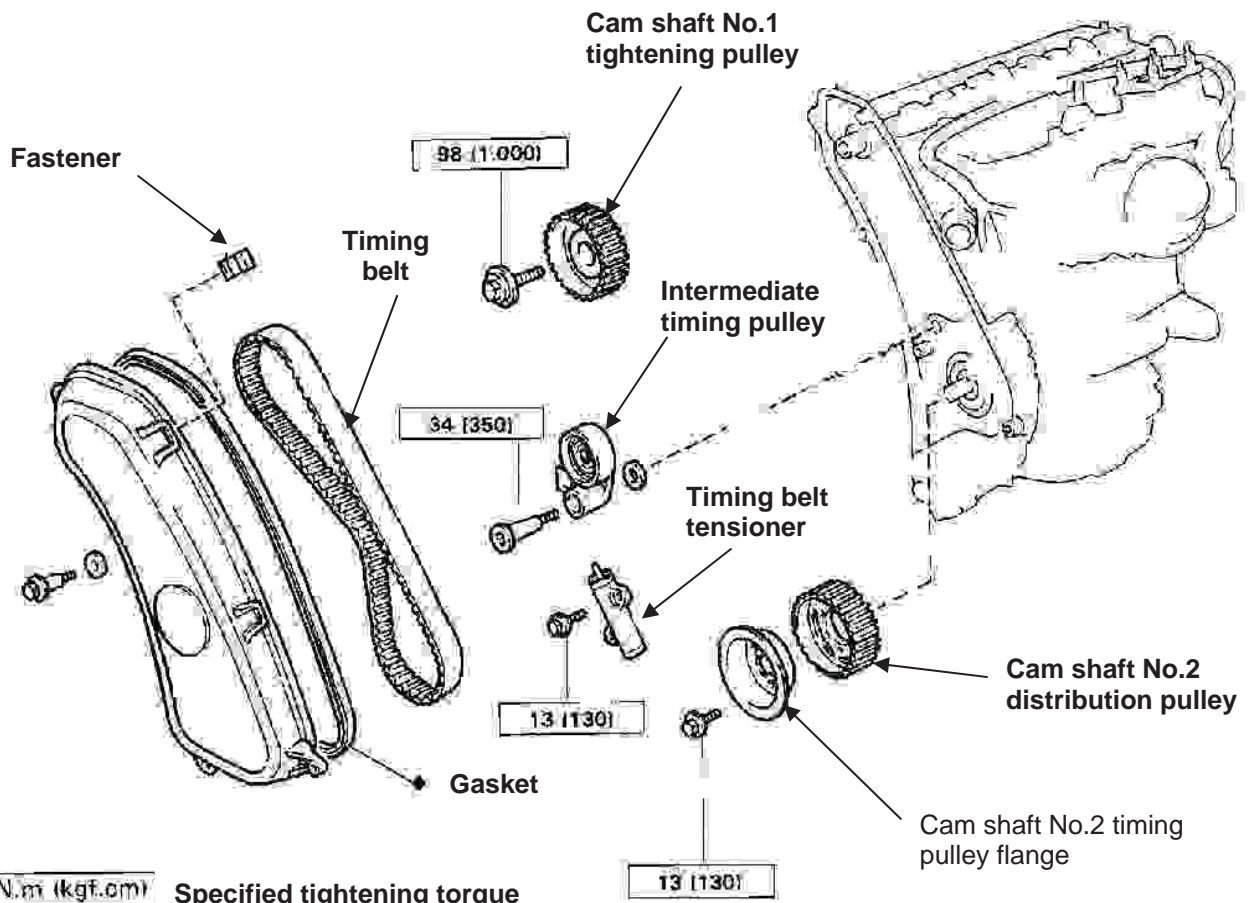

N.m (kgf.cm) Specified tightening torque
◆ - Non-reusable part

BALANCING SHAFT N°1 x OIL PUMP

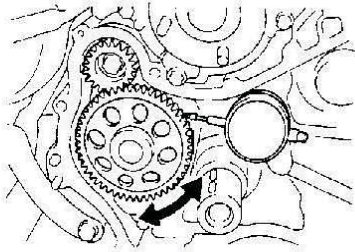

BALANCING SHAFT N°2 x INJECTION PUMP

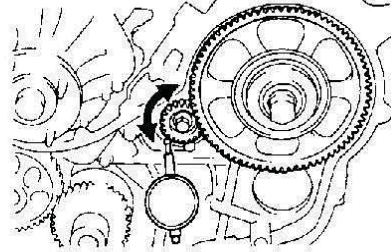

INTERMEDIATE GEAR X CRANCKSHAFT

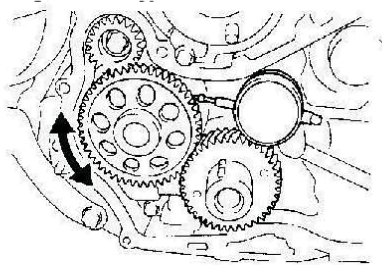
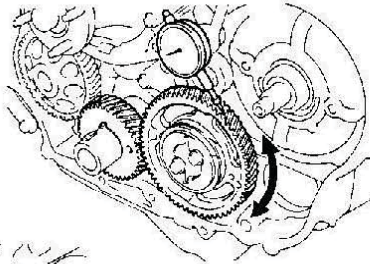

CRANCKSHAFT x OIL PUMP

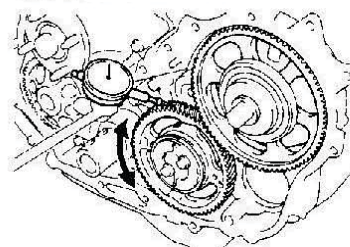

INTERMEDIATE GEAR x INJECTION PUMP

CYLINDER HEAD

Component parts (Removal and Reinstallation)

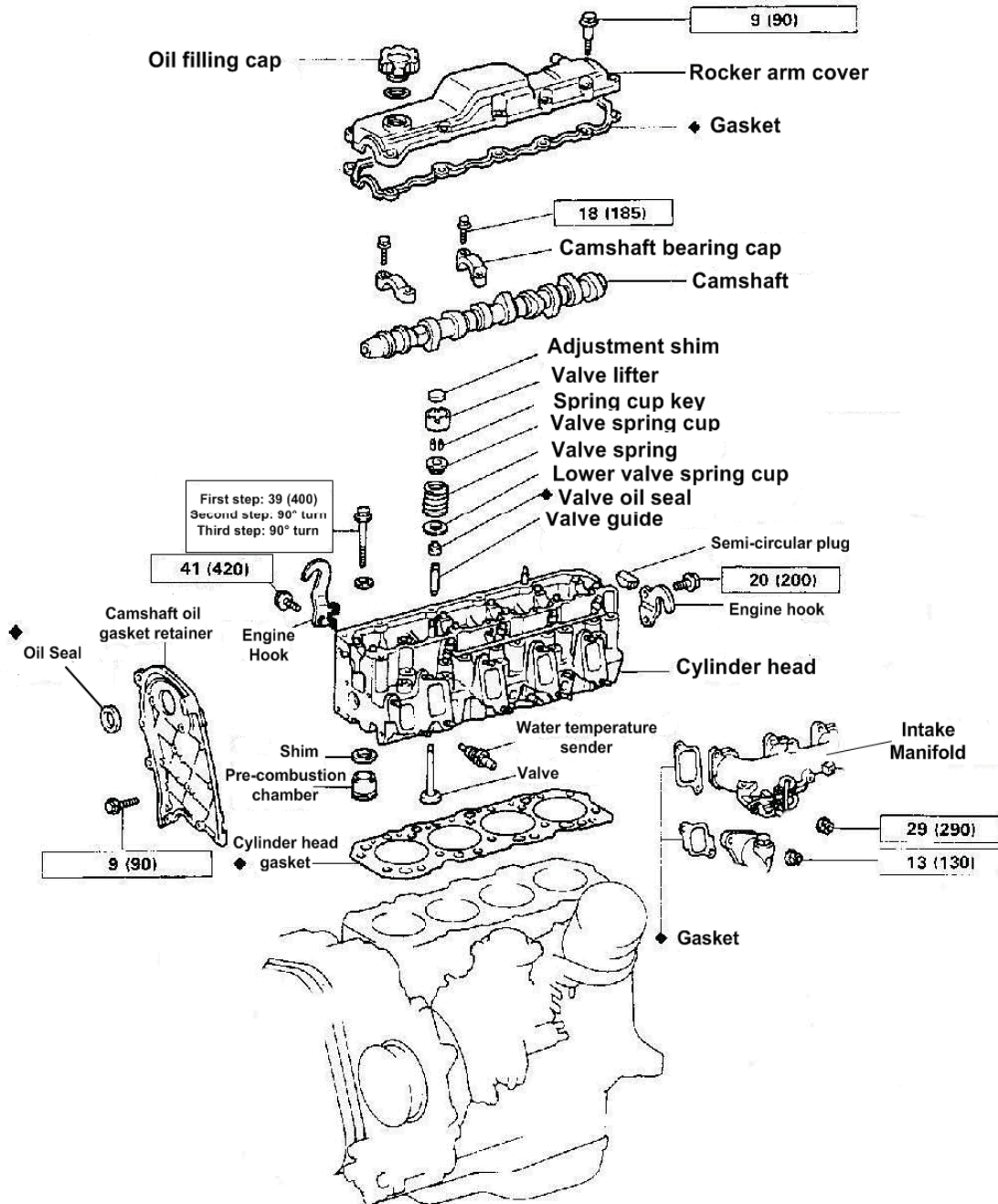

N.m (kgf.cm) : Specified tightening torque

◆ Non reusable part

CYLINDER BLOCK

Component parts (disassembly and reassembly)

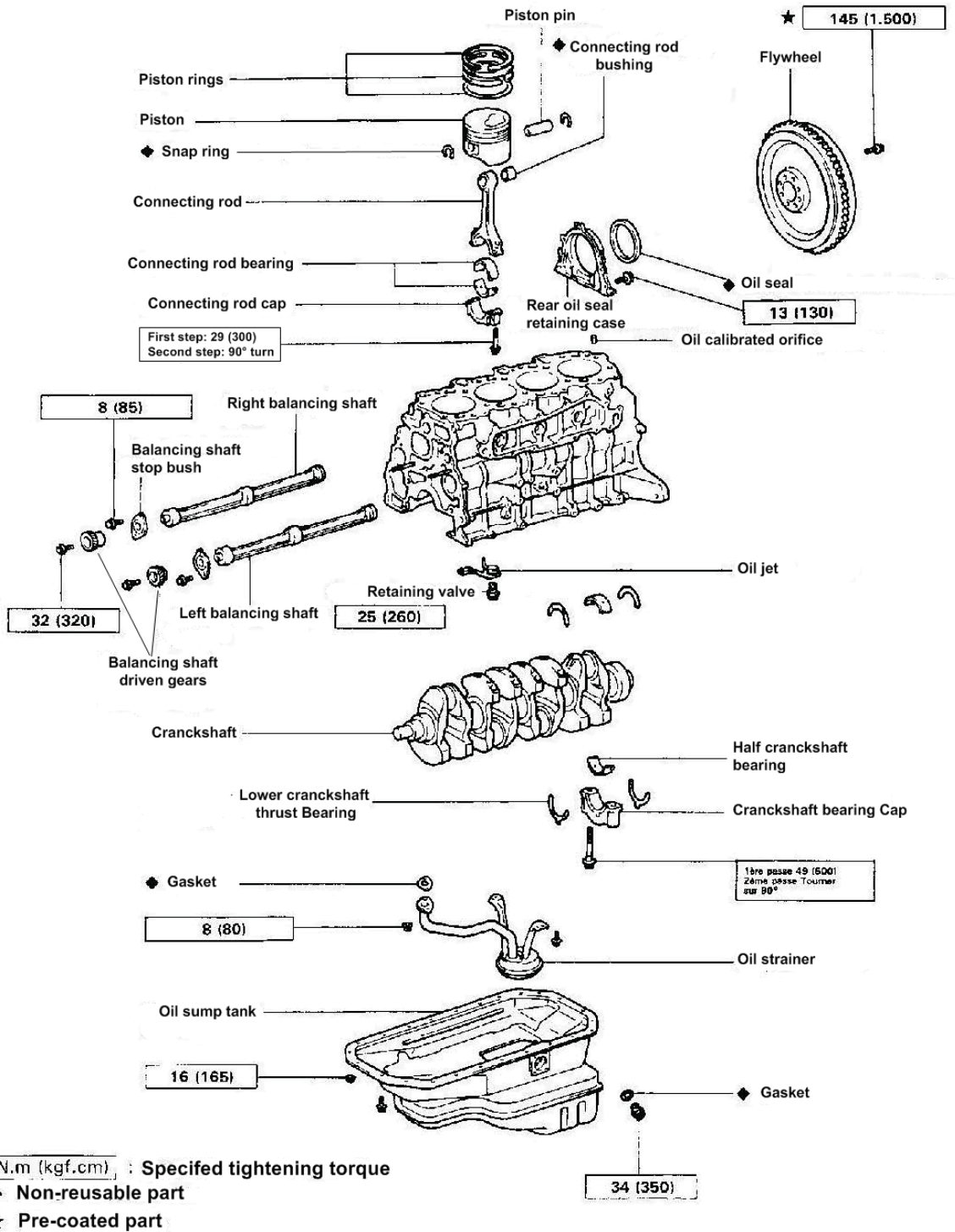

GLOW PLUGS

Component parts (removal and reinstallation)

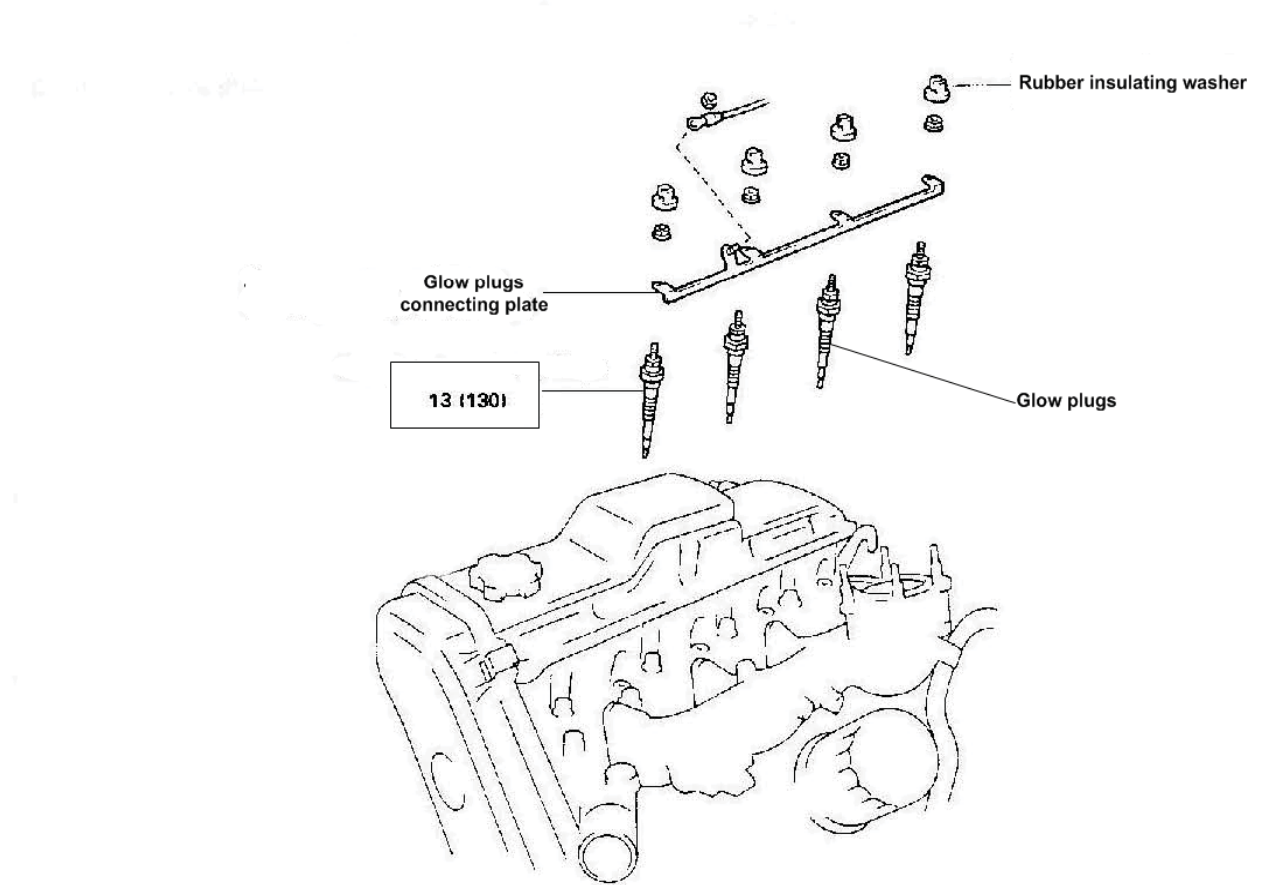

N.m (kgf.cm) : Specified tightening torque

◆ Non-reusable part

INJECTORS

Component parts (removal and reinstallation)

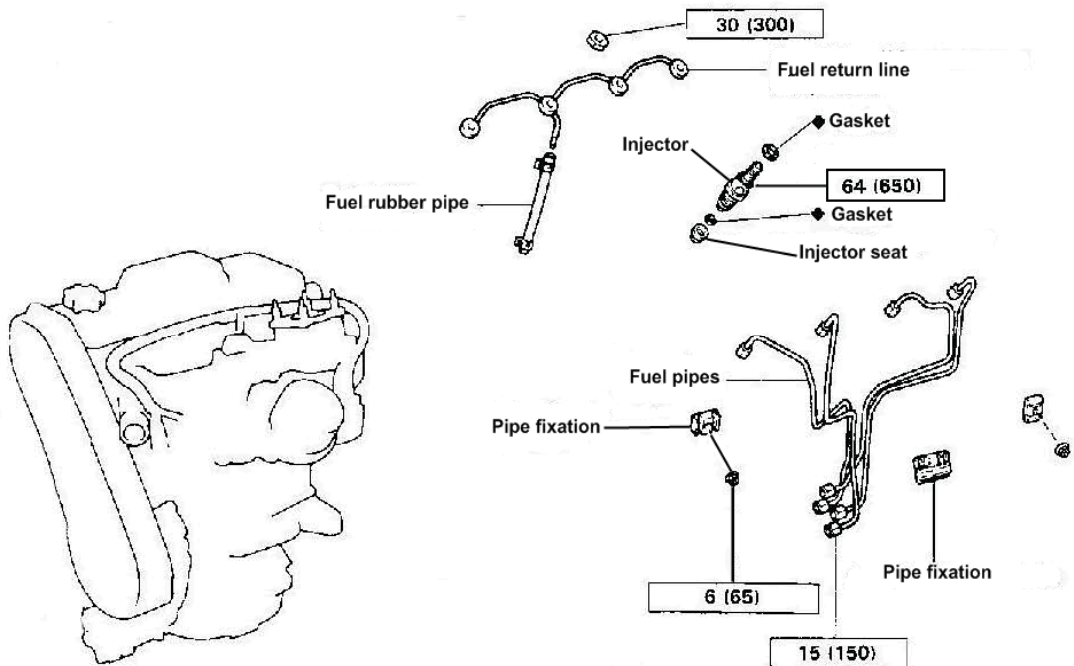

N.m (kgf.cm) : Specified tightening torque

◆ Non-reusable part

INJECTION PUMP

Component part (removal and reinstallation)

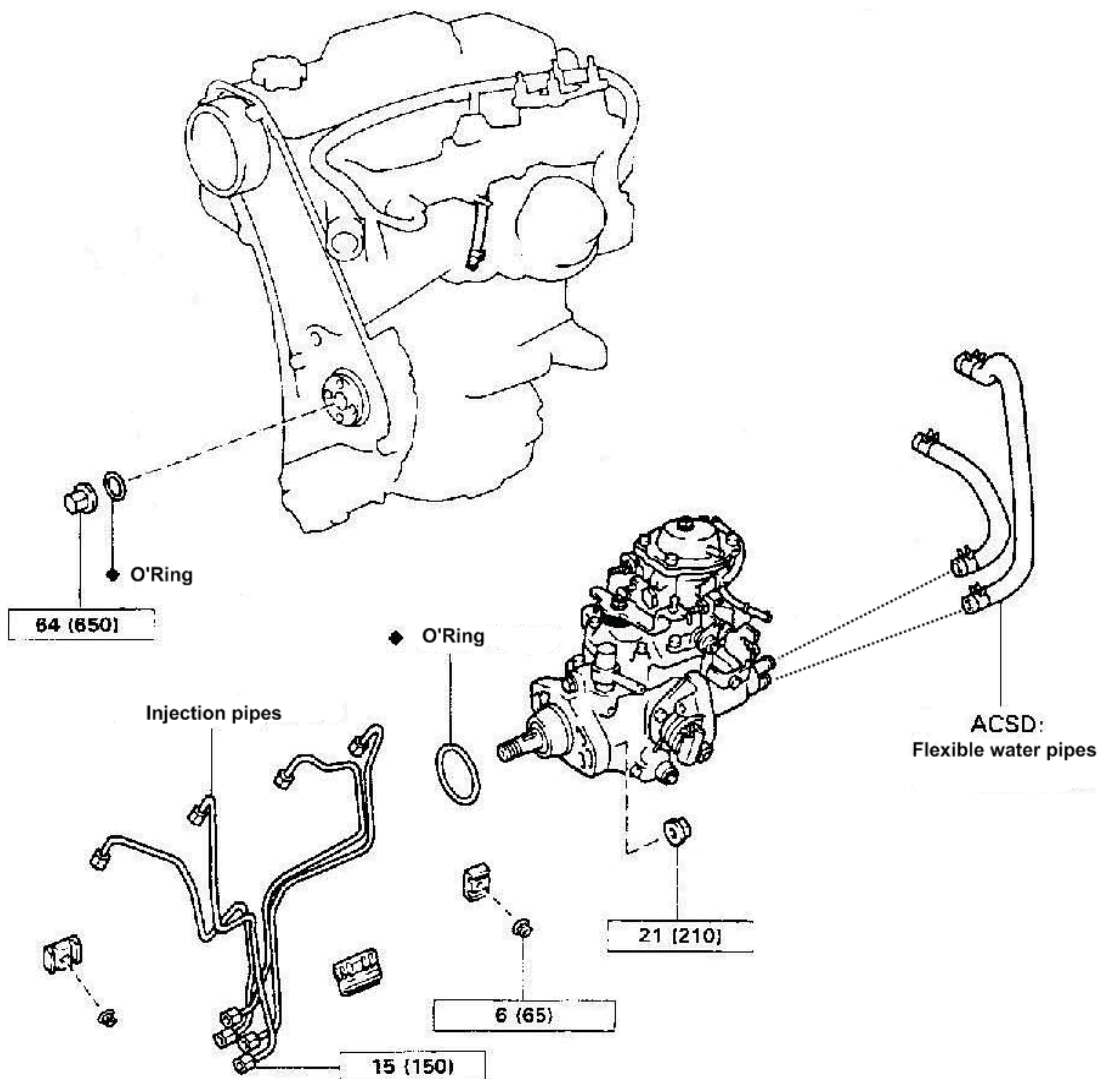

N.m (kgf.cm) : Specified tightening torque

◆ Non-reusable part

THERMOSTAT

Component parts (removal and reinstallation)

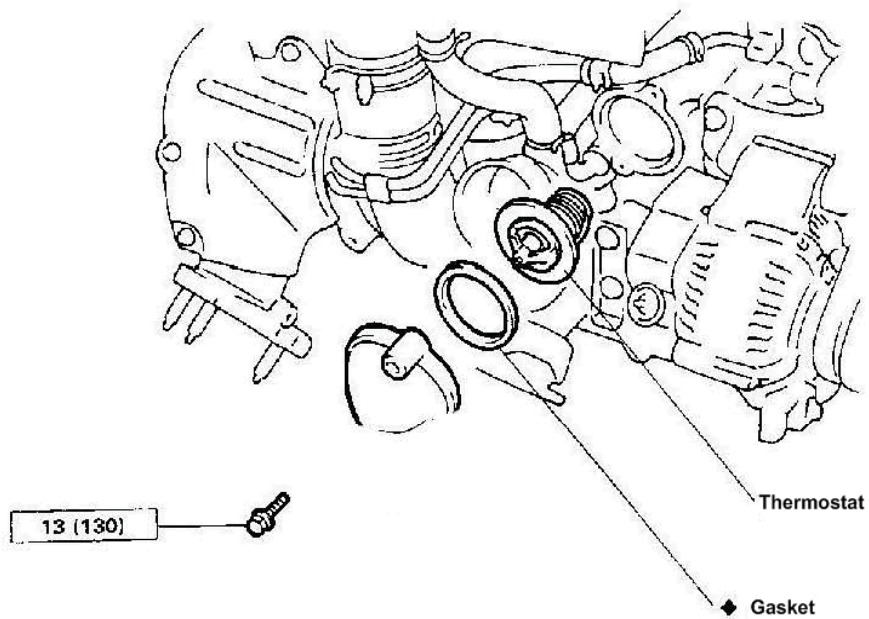

N.m (kgf.cm) : Specified tightening torque

◆ Non-reusable part

WATER PUMP

Component parts (removal and reinstalling)

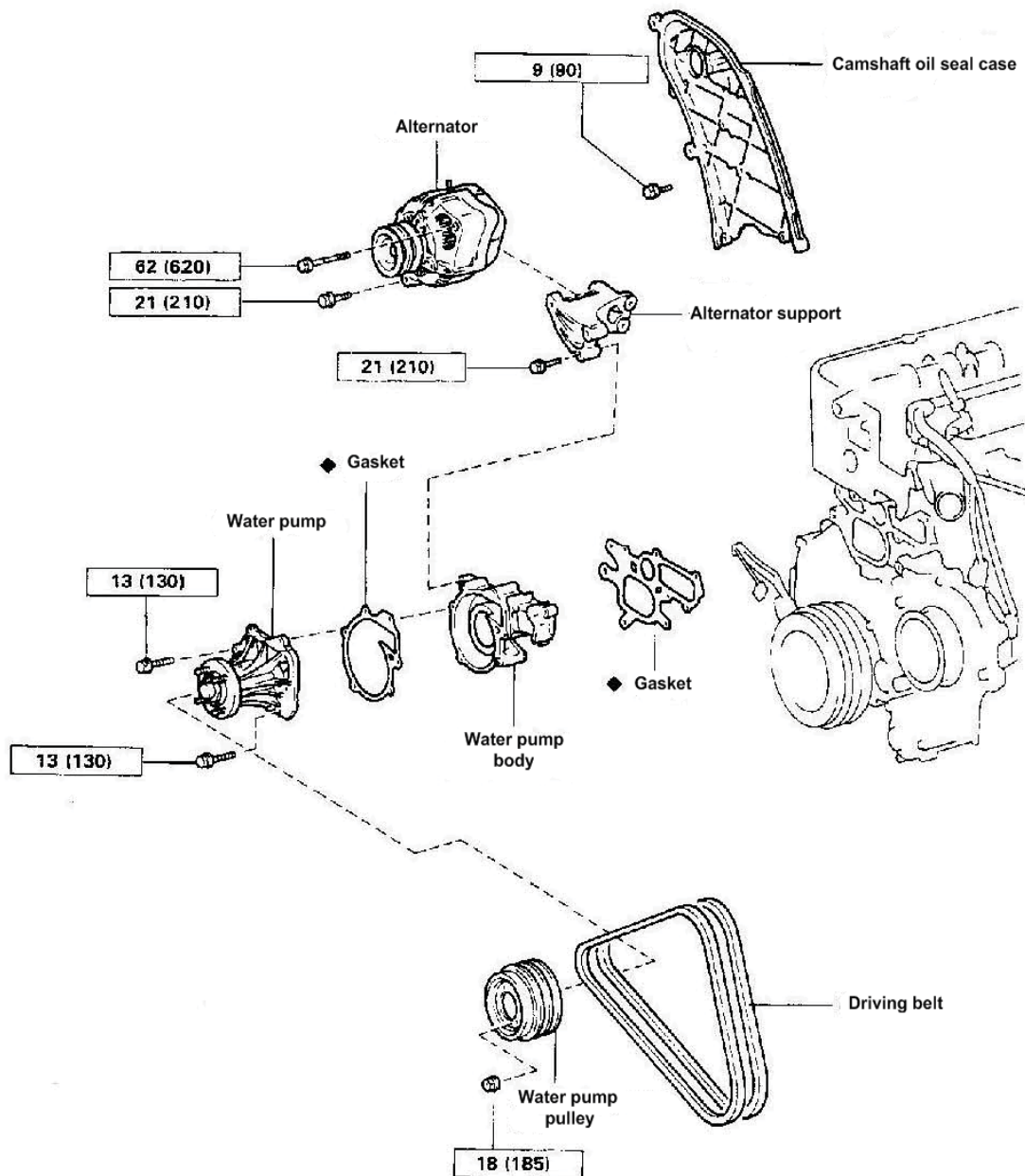

N.m (kgf.cm) : Specified tightening torque
◆ Non-reusable part

OIL PUMP

Component part (removal and reinstallation)

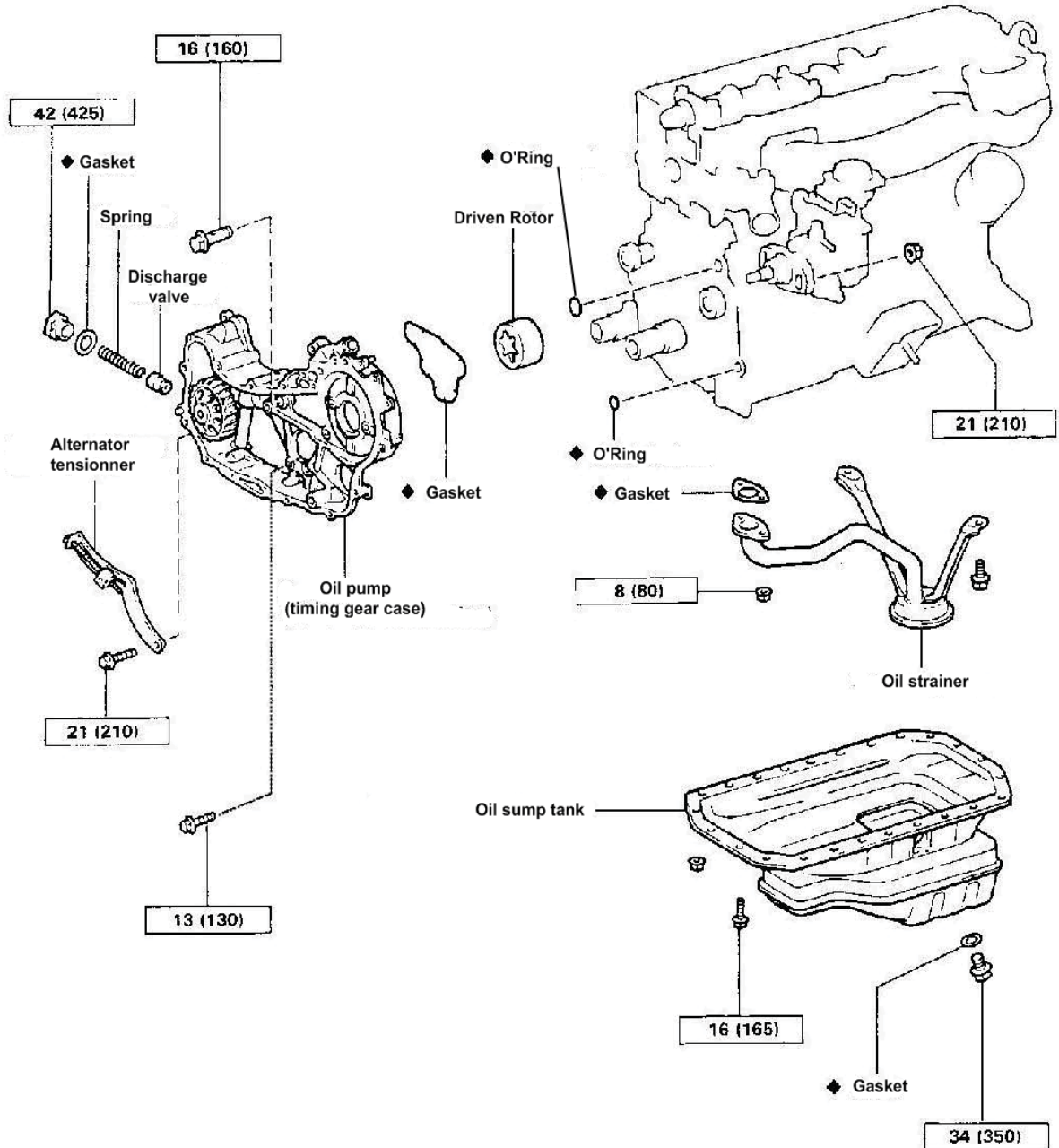

N.m (kgf.cm) : Specified tightening torque

◆ **Non-reusable part**

OIL COOLER

Component part (removal and reinstallation)

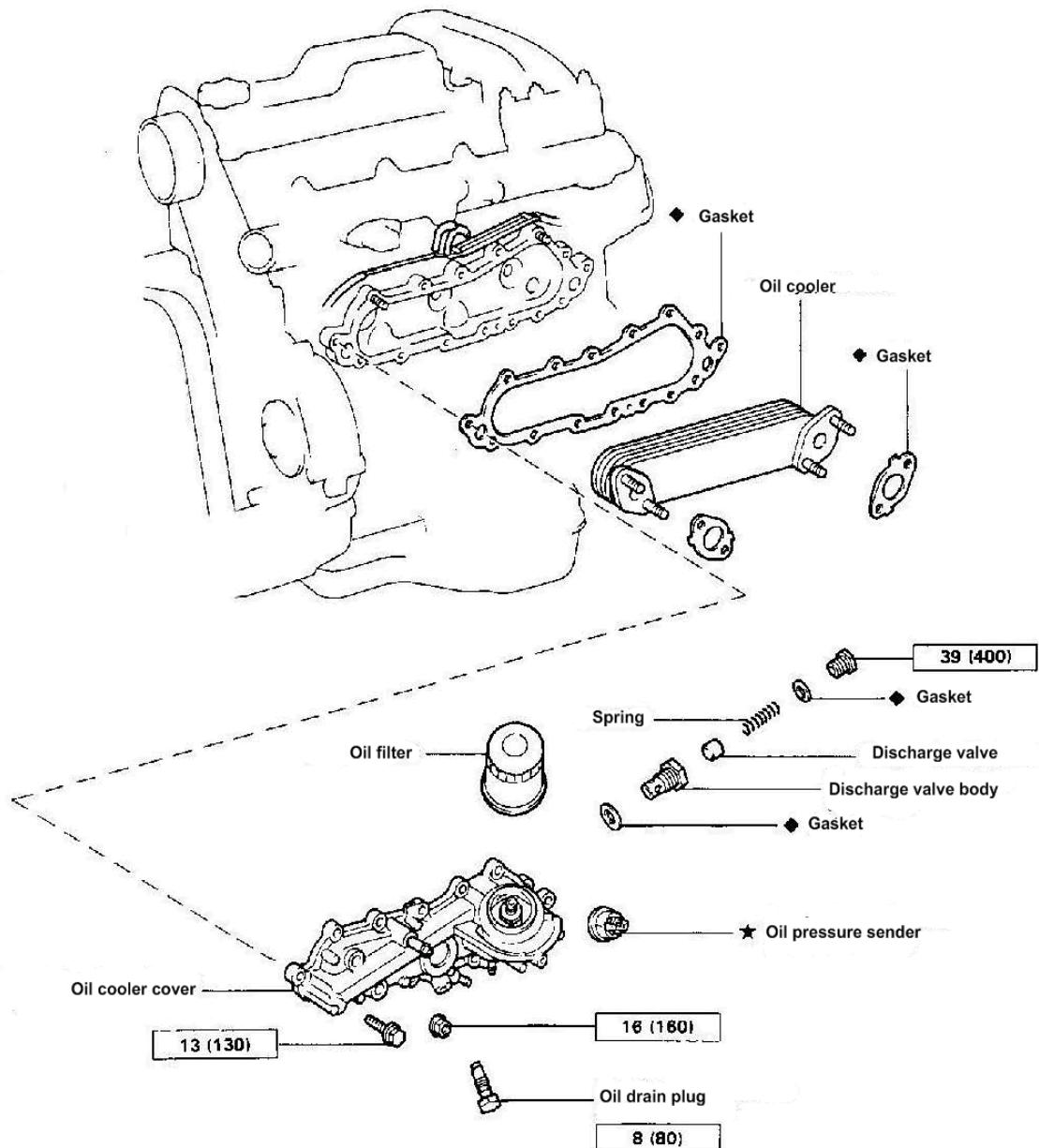

N.m (kgf.cm) : Specified tightening torque

◆ Non-reusable part

★ Pre-coated part

OIL JET

Component part (removal and reinstallation)

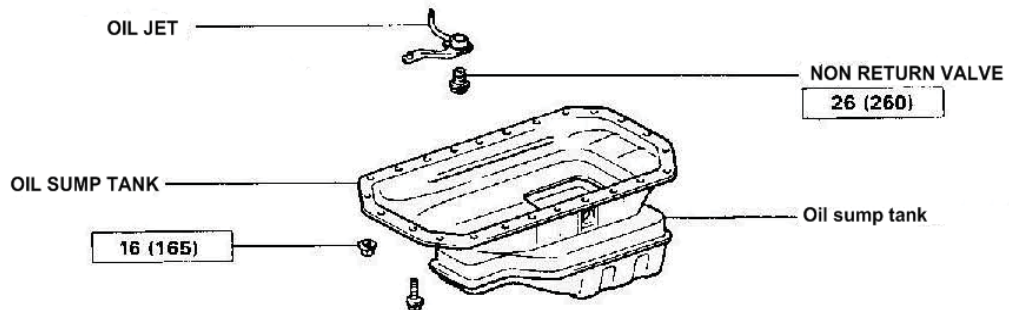
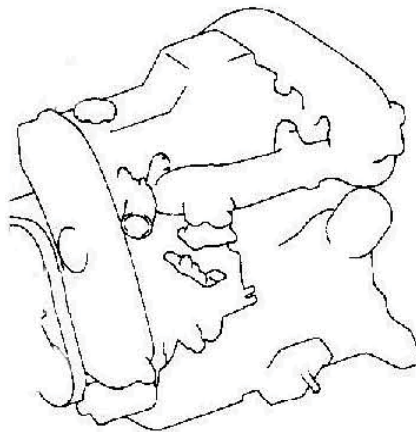

N.m (kgf.cm) : Specified tightening torque

TURBOCHARGER

(no replacing parts)

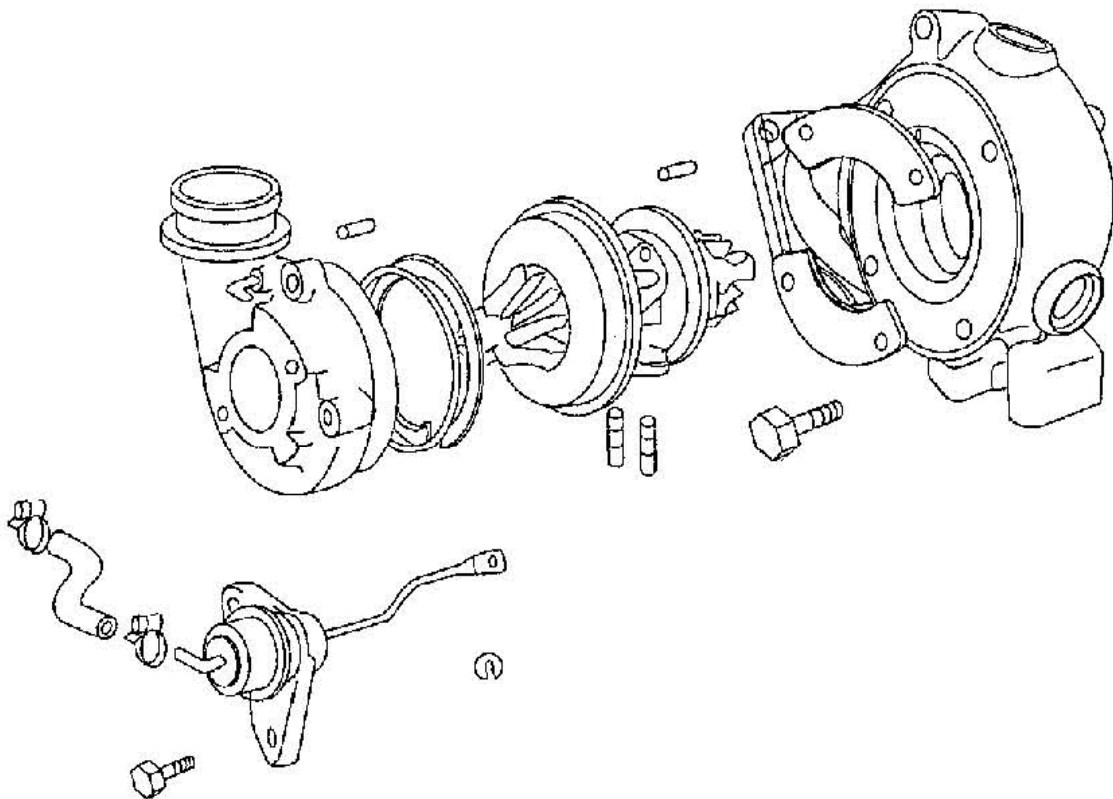

Manuel de Maintenance

MOTEUR Base M1KZ

T4.155 4.380 TDI 4.390 TDI



T4.155 4.380 TDI 4.390 TDI

(PART TWO)

CONTENTS:

Tightening torques (standard)
Specific tightening torques
Characteristics
Special tooling
Timing pinions
Cylinder head
Injection pump and injector
Fresh water pump and sender, thermostat
Pre-heating
Oil pressure, oil injectors, oil pump, oil radiator
Turbo charger
Cylinder block
Your notes

**Setting, adjustment and maintenance operations are described in
the
MAINTENANCE MANUAL**







STANDARD TIGHTENING TORQUES

the following list gives the different standard tightening torques for components when no specific tightening torque is specified in the manual

ALL TIGHTENING TORQUES ARE GIVEN IN Nm and in kgf/cm

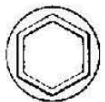
CHARACTERISTICS OF STANDARD BOLT TIGHTENING TORQUES

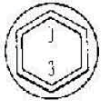
How to determine the resistance of a bolt

	Items	Category		Items	Category
Hexagonal head bolts	 Bolt head N° 4 - 4T 5 - 5T 6 - 6T 7 - 7T 8 - 8T 9 - 9T 10 - 10T 11 - 11T		Captive Stud	 Without marking 4T	
	 without marking 4T				
Hexagonal head bolt with collar Hexagonal head bolt with washer	 without marking 4T		Welded Bolt	 Groove 6T	
Hexagonal head bolt	 two embossed lines 5T				
Hexagonal head bolt with collar Hexagonal head bolt with washer	 Two embossed lines 6T				
Hexagonal head bolt	 three embossed lines 7T				
Hexagonal head bolt	 Four embossed lines 8T				

SPECIFIC STANDARD BOLT TORQUE

Category	Diameter mm	Pitch mm	Tightening torque			
			Hex head bolt		Hex head bolt with collar	
			N.m	kgf.cm	N.m	kgf.cm
4T	6	1	5	55	6	60
	8	1.25	12.5	130	14	145
	10	1.25	26	260	29	290
	12	1.25	47	480	53	540
	14	1.5	74	760	84	850
	16	1.5	115	1150	-	-
5T	6	1	6.5	65	7.5	75
	8	1.25	15.5	160	17.5	175
	10	1.25	32	330	36	360
	12	1.25	59	600	65	670
	14	1.5	91	930	100	1050
	16	1.5	140	1400	-	-
6T	6	1	8	80	9	90
	8	1.25	19	195	21	210
	10	1.25	39	400	44	440
	12	1.25	71	730	80	810
	14	1.5	110	1100	125	1250
	16	1.5	170	1750	-	-
7T	6	1	10.5	110	12	120
	8	1.25	25	260	28	290
	10	1.25	52	530	58	590
	12	1.25	95	970	105	1050
	14	1.5	145	1500	165	1700
	16	1.5	230	2300	-	-
8T	8	1.25	29	300	33	330
	10	1.25	61	620	68	690
	12	1.25	110	1100	120	1250
9T	8	1.25	34	340	37	380
	10	1.25	70	710	78	790
	12	1.25	125	1300	140	1450
10T	8	1.25	38	390	42	430
	10	1.25	78	800	88	890
	12	1.25	140	1450	155	1600
11T	8	1.25	42	430	47	480
	10	1.25	87	890	97	990
	12	1.25	155	1600	175	1800

SPECIFIC TIGHTENING TORQUES

TIGHTENING TORQUES

Component to tighten	N.m	kgf.cm	
Intake pipe x intake manifold	12	120	
Injection pump x timing gear casing	21	210	
Injection pump x injection pump spacer	15	150	
Injection pump tightening head cap bolt	17	170	
Cam shaft No.1 tightening pulley x cam shaft	98	1000	
Cam shaft No.2 tightening pulley x injection pump drive pinion	13	130	
Intermediate pulley bolt x timing gear casing	34	350	
Timing belt tensioner x timing gear casing	13	130	
Injection pump drive pinion x injection pump	64	650	
Intermediate pulley x timing gear casing	19	195	
Timing gear casing cover x timing gear casing	13	130	
Crankshaft pulley x crankshaft	363	3700	
Cam shaft oil gasket retainer x cylinder head	9	90	
Cam shaft bearing cap x cylinder head	18	185	
Cylinder head x cylinder block	1st stage 2nd stage 3rd stage	39 Turn 90° Turn 90°	400 Turn 90° Turn 90°
Injector x cylinder head	64	650	
Injector drop pipe x injector	29	300	
Water discharge pipe x cylinder head	16	165	
Intake manifold x cylinder head	20	200	
Oil level gauge guide x cylinder head	20	200	
Injection pipe x injector	15	150	
Injection pipe x injection pump	15	150	
Oil injector x cylinder block	25	260	
Crankshaft bearing cap x cylinder block	1st stage 2nd stage	49 Turn 90°	500 Turn 90°
Connecting rod cap x connecting rod	1st stage 2nd stage	29 Turn 90°	300 Turn 90°
Rear oil gasket retaining cage x cylinder block	13	130	
Balancing shaft pinion x balancing shaft	32	320	
Balancing shaft x cylinder block	8	85	
Rear closing plate x cylinder block	8	85	
Fly wheel x crankshaft	145	1480	

ENGINE CHARACTERISTICS

MAINTENANCE CHARACTERISTICS

MAINTENANCE DATA

Engine tuning	API quality engine oil		CD or greater
	Alternator drive belt sag under a 98 N (10kgf) force	New belt	
		Worn belt	6 – 8mm 8 – 12mm
	Alternator drive belt tension with special maintenance tool SST	New belt	45 – 55 kgf
		Worn belt	20 – 35 kgf
	Valve clearance (cold)	Intake	0.20 – 0.30 mm
		Exhaust	0.25 – 0.35 mm
	Valve new thickness adjustment shim thickness		2.50 mm
			2.55 mm
			2.60 mm
		2.65 mm	
		2.70 mm	
		2.75 mm	
		2.80 mm	
		2.85 mm	
		2.90 mm	
		2.95 mm	
		3.00 mm	
		3.05 mm	
		3.10 mm	
	3.15 mm		
	3.20 mm		
	3.25 mm		
	3.30 mm		
Injection time			
	Piston-plunger stroke		0.48 mm
Idle speed			800 ± 50 rpm
	Maximum speed		4.200 ± 50 rpm
Compression pressure	at 250 rpm	STD	3.040 kPa (31.0 kgf/cm ²) or more
		Limited	1.961 kPa (20.0 kgf/cm ²)
	Pressure difference between cylinders		490 kPa (5.0 kgf/cm ²) or less
Timing belt tensioner	Protrusion (of casing surface)		9.0 – 9.8 mm
Timing gears	Intermediate toothed wheel inner diameter		44.000 – 44.025 mm
	Intermediate toothed wheel shaft diameter		43.985 – 44.000mm
	Intermediate toothed wheel lubrication clearance	STD	0.025 – 0.060 mm
		Limited	0.20 mm
	Timing toothed wheel tooth clearance	STD	0.02 – 0.15 mm
		Limited	0.20 mm
Timing intermediate toothed wheel axial clearance	STD	0.05 – 0.15 mm	
	Limited	0.30 mm	

Cylinder head	Deformation	Limit	0.15 mm
	Valve seat		
	Grinding angle		30°, 45°, 60°
	Contact angle		45°
	Contact width	Intake Exhaust	1.5 – 1.9 mm 1.8 – 2.2 mm
Outside diameter of the cylinder head assembly bolts	STD		11.8 – 12.0 mm
	Limited		11.6 mm
	Installed cylinder head gasket thickness	Hole No. "1" Hole No. "3" Hole No. "5"	0.80 – 0.90 mm 0.90 – 1.00 mm 1.00 – 1.10 mm
Valve guide bush	Inside diameter		8.010 – 8.030 mm
	Outside diameter (ground part)	STD Top dimension 0.05	13.000 – 13.027 mm 13.050 – 13.077 mm
Valve	Valve overall length	STD Limit	103.29 – 103.69 mm 102.79 mm
	Valve contact surface inclination		45.5°
	Valve stem diameter	Intake Exhaust	7.975 – 7.990 mm 7.960 – 7.975 mm
	Valve stem lubrication clearance	STD (Intake) (Exhaust)	0.020 – 0.055 mm 0.035 – 0.070 mm
		Limit (Intake) (Exhaust)	0.08mm 0.10 mm
Valve head thickness	STD (Intake) (Exhaust)	1.6 mm 1.7 mm	
	Limit (Intake) (Exhaust)	1.1 mm 1.2 mm	
Valve spring	Squaring value	Limit	2.0 mm
	Length no load		48.54 mm
	Tension on load on 37.0 mm		301 – 332 N (30.7 – 33.9 Kg/cm ²)
Valve lifter	Valve lifter diameter		40.892 – 40.902 mm
	Valve lifter bore		40.930 – 40.950 mm
	Lubrication clearance	STD Limit	0.028 – 0.058 mm 0.10 mm
Manifold	Warping	Limit	0.40mm
Cam shaft	Thrust bearing clearance	STD	0.08 – 0.18 mm
		Limit	0.25 mm
	Pivot lubrication clearance	STD	0.025 – 0.062 mm
		Limit	0.10 mm
	Pivot diameter	Limit	27.969 – 27.985 mm
Ovalization	Limit	0.06 mm	
	Cam peak height	STD (Intake) (Exhaust)	54.810 – 54.910 mm 56.140 – 56.240 mm
		Limit (Intake) (Exhaust)	54.39 mm 55.72 mm

Combustion chamber	Protrusion		less 0.03 – more 0.02 mm
	Thickness shim thickness		0.05 mm 0.10 mm
Cylinder block	Cylinder head surface warp	Limit	0.10 mm
	Cylinder bore diameter	STD (Item 1)	96.000 – 96.010 mm
		(Mark 2)	96.010 – 96.020 mm
		(Mark 3)	96.020 – 96.030 mm
Limit (STD)		96.230 mm	
Crankshaft bearing trunnion bore diameter (Reference)	STD (Item 1)	75.000 – 75.006 mm	
	(Item 2)	75.006 – 75.012 mm	
	(Item 3)	75.012 – 75.018 mm	
Pistons and rings	Piston diameter	STD (Item 1)	95.940 – 95.950 mm
		(Item 2)	95.950 – 95.960 mm
		(Item 3)	95.960 – 95.970 mm
		Top dimension 0.50	96.440 – 96.470 mm
		Top dimension 0.75	96.690 – 96.720 mm
	Ring lubrication clearance	STD	0.050 – 0.070 mm
		Limit	0.14 mm
	Piston groove	Top compression ring	0.060 – 0.110 mm
		Sealing ring	0.060 – 0.100 mm
		Oil scraper ring	0.020 – 0.060 mm
Ring gap	STD (Top compression ring)	0.350 – 0.570 mm	
	(Sealing ring)	0.400 – 0.600 mm	
	(Oil scraper ring)	0.200 – 0.500 mm	
	Limit (Top compression ring)	1.03 mm	
	(Sealing ring)	1.10 mm	
	(Oil scraper ring)	0.87 mm	
Connecting rod	Thrust clearance	STD	0.10 – 0.30 mm
		Limit	0.40 mm
	Connecting rod bearing center wall thickness (Reference)	STD (Mark 2)	1.486 – 1.489 mm
		(Mark 3)	1.489 – 1.492 mm
		(Mark 4)	1.492 – 1.495 mm
		(Mark 5)	1.495 – 1.498 mm
		(Mark 6)	1.498 – 1.501 mm
	Connecting rod lubrication clearance (Bottom dimension 0.25 and bottom dimension 0.50)	STD (STD)	0.036 – 0.054 mm
		Limit	0.037 – 0.077 mm 0.10 mm
Connecting rod bend	Limit over 100 mm	0.03 mm	
Connecting rod twist	Limit over 100 mm	0.15 mm	
Connecting rod assembly bolt internal diameter	STD	8.400 – 8.600 mm	
	Limit	8.20 mm	
Connecting rod small end bush inner diameter		34.012 – 34.024 mm	
Piston pin diameter		34.000 – 34.012 mm	

Connecting rod	Piston pin lubrication clearance	STD Limit	0.008 – 0.016 mm 0.03 mm
	Connecting rod small end inner diameter (Reference)	STD (Item 1) (Item 2) (Item 3)	62.014 – 62.020 mm 62.020 – 62.026 mm 62.026 – 62.032 mm
Crankshaft	Stop clearance	STD	0.04 – 0.240 mm
	Piston pin lubrication clearance	Limit	0.30 mm
	Thrust bush thickness	STD (STD)	2.430 – 2.480 mm
		(Bottom dimension 0.25)	2.555 – 2.605 mm
		(Bottom dimension 0.125)	2.493 – 2.543 mm
	Crankshaft bearing pivot lubrication clearance	STD (STD)	0.036 – 0.054 mm
		(Bottom dimension 0.25 and bottom dimension 0.50)	0.037 – 0.077 mm
		Limit	0.10 mm
	Crankshaft bearing pivot diameter	STD (Mark 1)	69.994 – 70.000 mm
		(Mark 2)	69.988 – 69.994 mm
		(Mark 3)	69.982 – 69.988 mm
		Bottom dimension 0.25	69.745 – 69.755 mm
		Bottom dimension 0.50	69.495 – 69.505 mm
	Bearing center wall thickness (Reference)	STD (Mark 2)	2.479 – 2.482 mm
	(Mark 3)	2.482 – 2.485 mm	
	(Mark 4)	2.485 – 2.488 mm	
	(Mark 5)	2.488 – 2.491 mm	
	(Mark 6)	2.491 – 2.494 mm	
Crank pin diameter	STD (Mark 1)	58.994 – 59.000 mm	
	(Mark 2)	58.988 – 58.994 mm	
	(Mark 3)	58.982 – 58.988 mm	
	Bottom dimension 0.25	58.745 – 58.755 mm	
	Bottom dimension 0.50	58.495 – 58.505 mm	
Ovalization	Limit	0.06 mm	
Pivot ovalization and conicity	Limit	0.020 mm	
Crank pin ovalization and conicity	Limit	0.020 mm	
Crankshaft bearing cap bolt external diameter	STD	13.500 – 14.000 mm	
	Limit	12.60 mm	
Balancing shaft	Axial clearance	STD	0.065 – 0.140 mm
		Limit	0.25 mm
	Pivot No.1 lubrication clearance	STD	0.040 – 0.079 mm
		Limit	0.180 mm
	Pivot No.2 lubrication clearance	STD	0.040 – 0.079 mm
		Limit	0.190 mm
	Pivot No.3 lubrication clearance	STD	0.050 – 0.089 mm
		Limit	0.180 mm
	Bearing No.1 internal diameter		42.000 – 42.020 mm
	Bearing No.2 internal diameter		41.000 – 41.020 mm
Bearing No.3 internal diameter		32.000 – 32.020 mm	
Pivot No.1 diameter		41.941 – 41.960 mm	
Pivot No.2 diameter		40.931 – 40.950 mm	
Pivot No.3 diameter		31.941 – 31.960 mm	

BASIC SPECIAL TOOLS

- Alternator belt tension controller
 - **970 312 375**

- Valve adjustment tool:
 - **970 312 377**

- Injection pump dial gauge support
 - **970 312 378**

- Pulley/pinion extractor box
(Usable on all NANNI models)
 - **970 312 374**

- Valve spring compressor
 - **970 312 372**

- Combustion chamber extractor
 - **970 312 373**

- Crankshaft spy joint installation tool:
 - **970 312 376**

TIMING GEARS

When performing any work on the timing, it is mandatory to set the engine to the TDC (Top Dead Center)

CYLINDER N°4 (ENGINE FLY WHEEL SIDE)

TIMING BELT

Component part
Removal and reinstallation

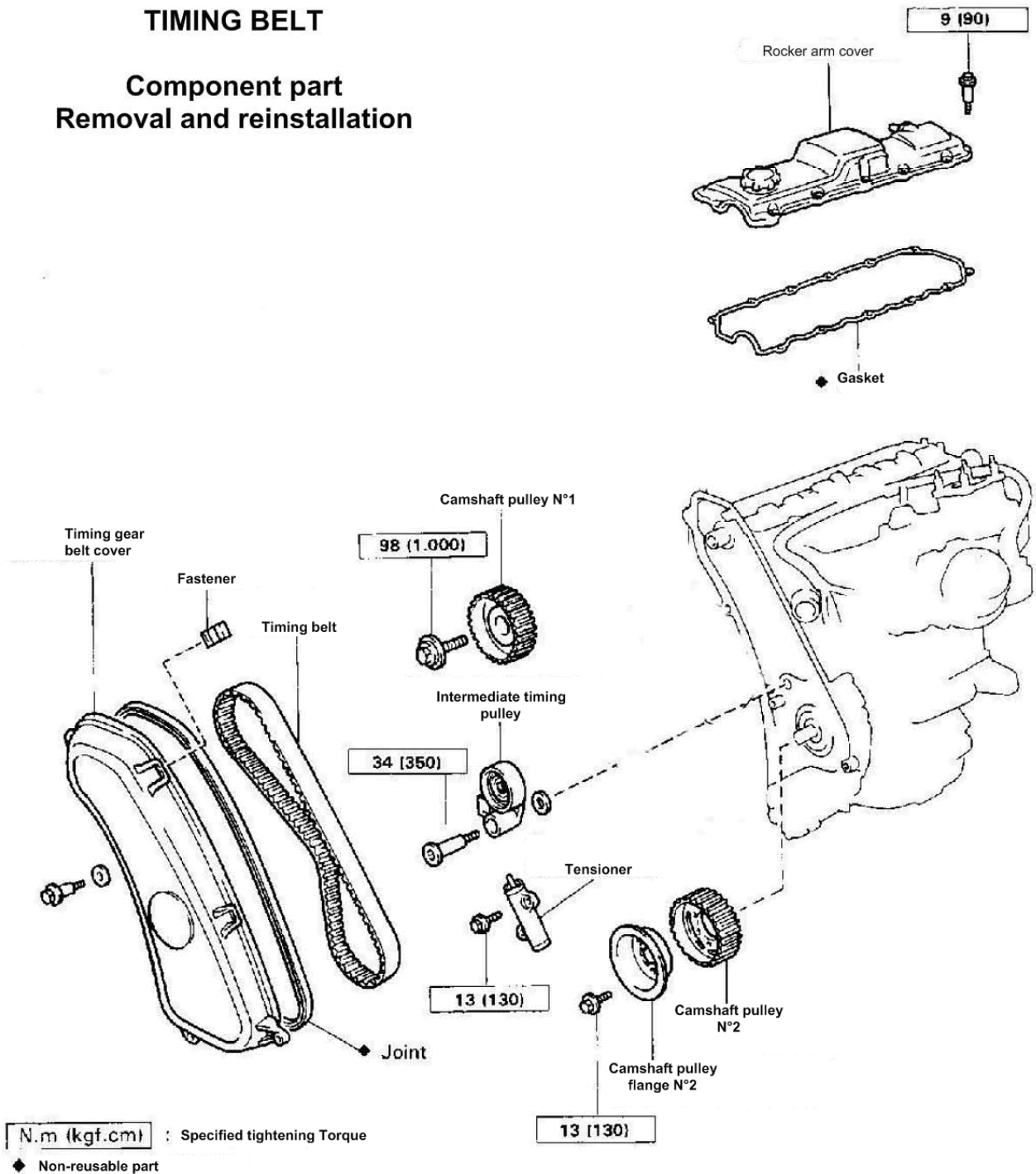

TIMING GEARS

Component part (Removal and reinstallation)

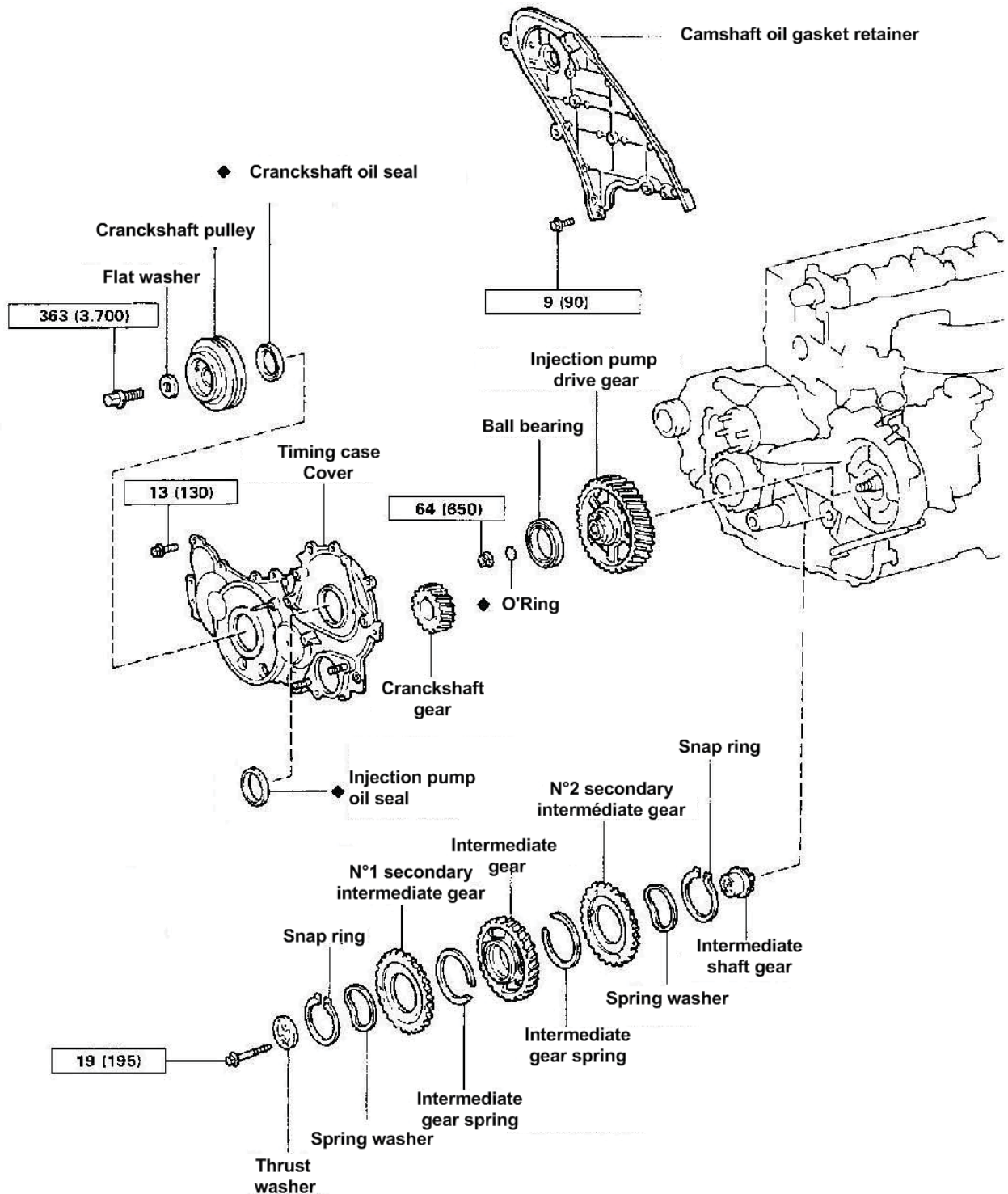

N.m (kgf.cm) : Specified tightening torque

◆ Non-reusable part

REMOVING THE TIMING BELT

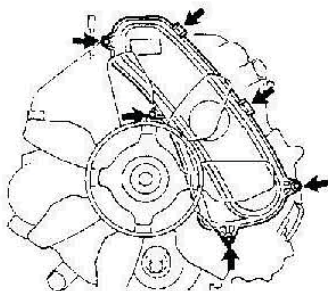

1. REMOVE THE TIMING BELT PROTECTION COVER

Remove the four assembly bolts, the sealing washers, the two fasteners, the timing belt protection cover and the gasket.

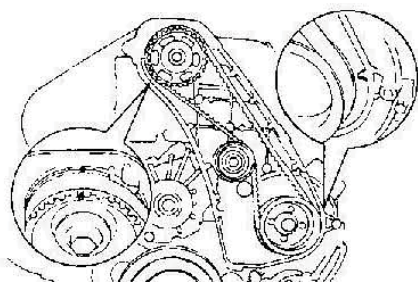

2. PUT No.4 CYLINDER IN TOP DEAD CENTER POSITION ON ITS COMPRESSION STROKE

Rotate the crankshaft fully clockwise to make the notches in No.1 and No.2 cam shaft pulleys coincide with the top dead center timing marks

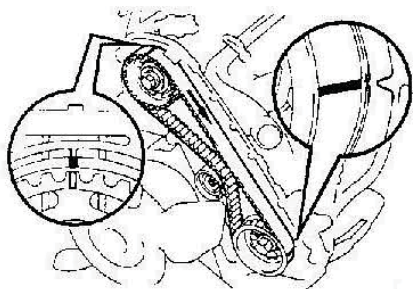

3. WHEN THE TIMING BELT IS RE-USED, MAKE A MARK ON THE TIMING BELT

WARNING:

If the timing belt is re-used, make a mark in the rotation direction on the timing belt (engine rotation direction mark) then make timing alignment marks on the timing pulleys and the timing belt by working as shown in the figure opposite.

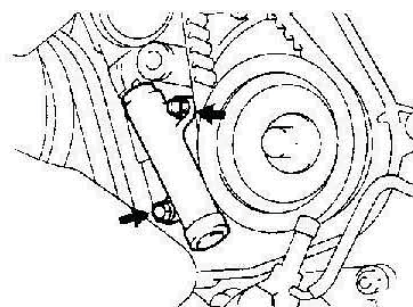

4. REMOVE THE TIMING BELT TENSIONER

Loosen alternately the two assembly bolts and then remove them and remove the timing belt tensioner.

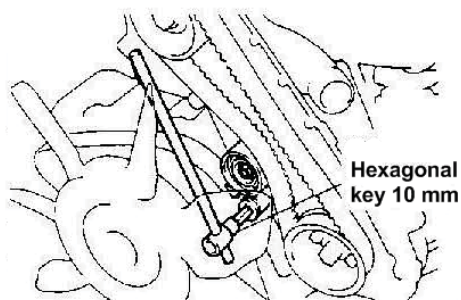

5. REMOVE THE TIMING BELT INTERMEDIATE PULLEY

Remove the assembly bolt using a 10 mm hex head wrench, intermediate timing belt pulley and the flat washer.

6. REMOVE THE TIMING BELT

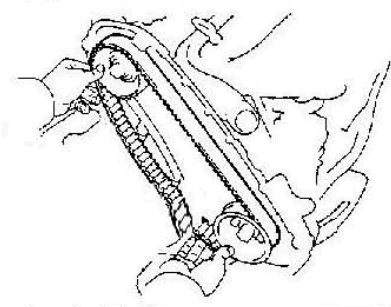

7. REMOVE CAM SHAFT No.2 TIMING PULLEY

Remove the four assembly bolts, the cam shaft No.2 timing pulley flange and the cam shaft No.2 timing pulley.

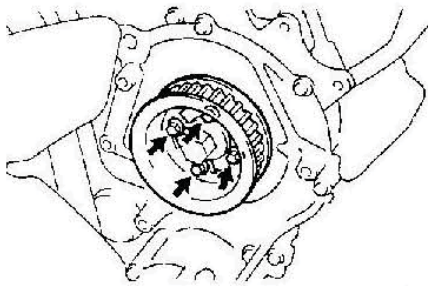

8. REMOVE THE ROCKER COVER

Remove the ten assembly bolts, the two attachment nuts, the rocker cover and the gasket.

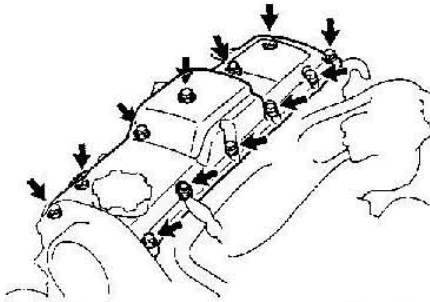

9. REMOVE THE CAM SHAFT No.1 TIMING PULLEY

- a. Secure the top part of the cam shaft with a hex head wrench and remove the cam shaft No.1 timing pulley bolt and cam shaft No.1 timing pulley.
- b. Remove the assembly key.

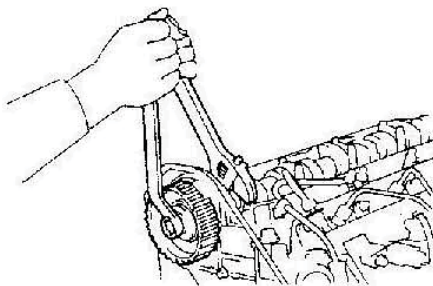

REMOVING THE TIMING PINIONS

(Refer to component part illustration for disassembly and reassembly)

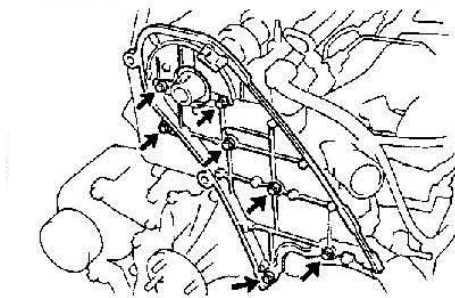

1. REMOVE THE TIMING BELT

2. REMOVE THE TIMING BELT AND PULLEYS

3. REMOVE THE CAM SHAFT OIL GASKET RETAINER

Remove the seven assembly bolts and cam shaft oil gasket retainer.

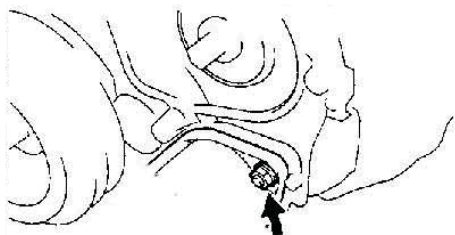

4. REMOVE THE CRANKSHAFT PULLEY

- a. Remove the assembly bolt and the crankshaft pulley plate using the special maintenance tools

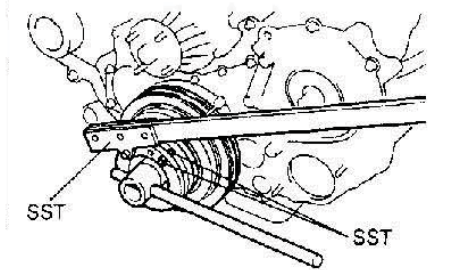

5. REMOVE THE CRANKSHAFT PULLEY

- a. Remove the assembly bolt and the crankshaft pulley plate using the special maintenance tools

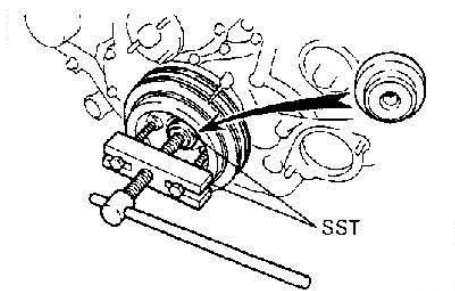

- b. .Remove the crankshaft pulley using the special maintenance tool.

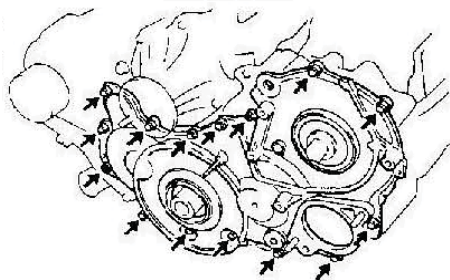

c. Remove the thirteen assembly bolts and the two attachment nuts.

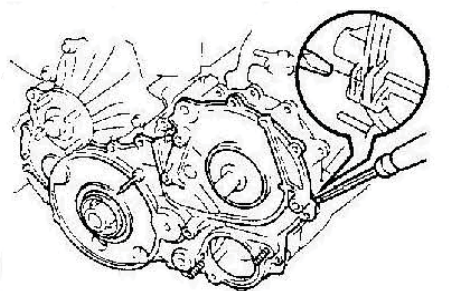

c. Prise opens the timing cover.

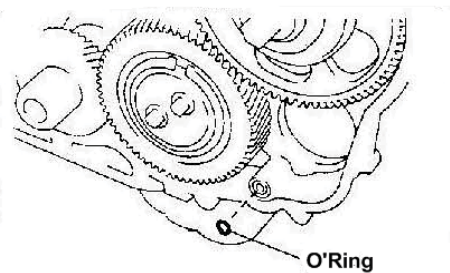

d. Remove the o-ring

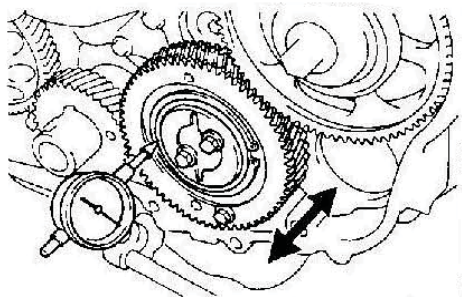

6. CHECK THE AXIAL CLEARANCE OF THE INTERMEDIATE TOOTHED WHEEL

Use a dial gauge to measure the axial clearance of the intermediate toothed wheel.

Nominal axial clearance: **0.05 – 0.15 mm**
Axial clearance limit: **0.30 mm**

Replace the pressure plate if the recorded clearance is greater than the limit stipulated in specifications. If necessary, replace the intermediate toothed wheel and/or the intermediate toothed wheel shaft.

7. REMOVE THE TIMING TOOTHED WHEELS

REMARK:

- * The alignment mark engraved on the surface of each toothed wheel is directed towards the front of the engine
 - * Make sure not to damage the teeth of the toothed wheels when removing and reinstalling toothed wheels.
- Do not use scratched or damaged parts as they cause noise.

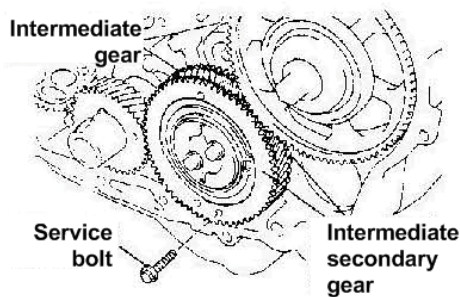

A. Removing the cam shaft timing toothed wheel

- a. Secure the secondary intermediate toothed wheels of the intermediate toothed wheel using the service bolt.

Recommended service bolt:

Thread diameter:	6 mm
Thread pitch:	1.0 mm
Bolt length:	28 mm

WARNING:

When removing the intermediate toothed wheel, check that the twist force of the secondary toothed wheel spring has been eliminated by performing the above-mentioned operation.

- b. Use the special maintenance tool SST to remove the crankshaft timing toothed wheel

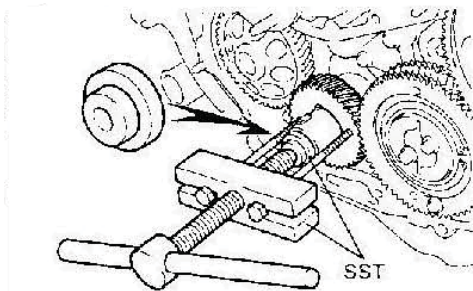

B. Remove the intermediate toothed wheel.

Remove the two assembly bolts, the stop washer and the intermediate toothed wheel and intermediate toothed wheel shaft assembly

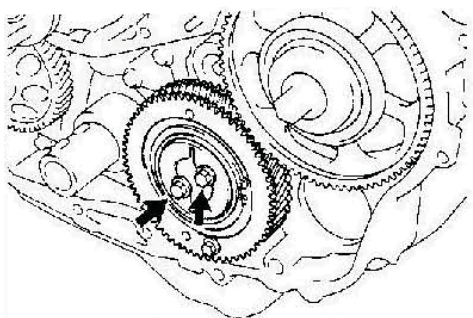

C. Remove the injection pump drive pinion

- a. Remove the attachment nut of the injection pump drive pinion using the special maintenance tool.

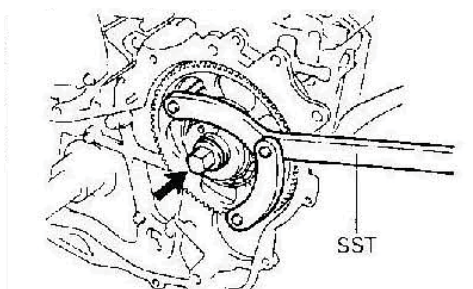

- b. Remove the o-ring.

c. Remove the injection pump drive pinion using the special maintenance tool.

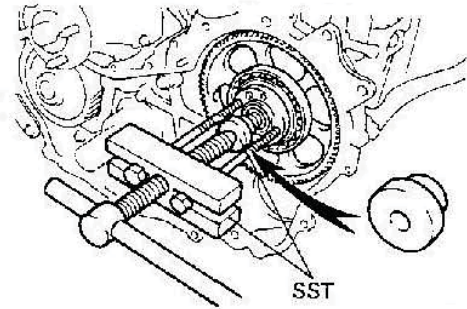

REMARK:

- * Tighten the two assembly bolts of the special maintenance tool SST on more than 8mm
- * Install the special maintenance tool SST so that it is balanced

8. REMOVE THE INTERMEDIATE TOOTHED WHEEL

a. Install the intermediate toothed wheel and the secondary No.2 intermediate toothed wheel in a vice.

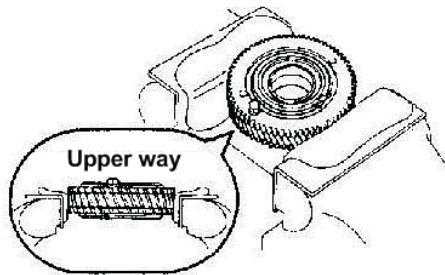

REMARK: Make sure not to damage the toothed wheels during this operation.

b. Use the special maintenance tool SST to turn the No.1 secondary intermediate toothed wheel clockwise, and then remove the service bolt

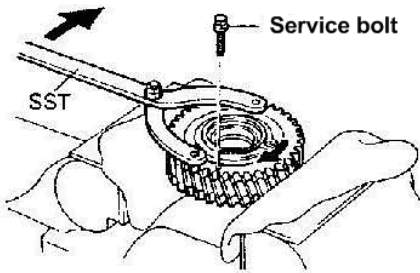

c. Remove the snap ring with snap ring pliers.

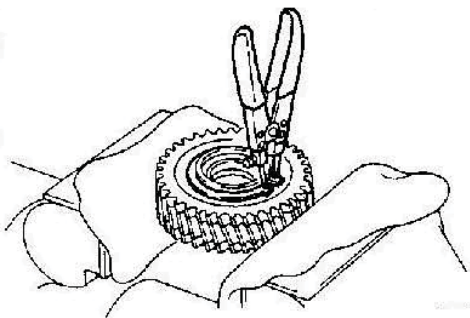

d. Remove the following parts:

- (1) Star washer
- (2) No.1 secondary intermediate toothed wheel
- (3) Intermediate toothed wheel spring

e. Remove the intermediate toothed wheel assembly from the vice and turn it over.

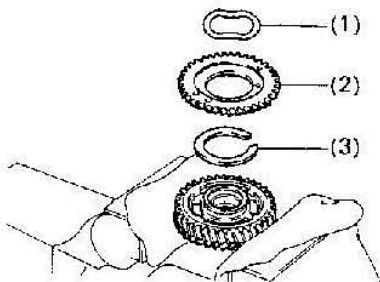

f. Install the intermediate toothed wheel in a vice.

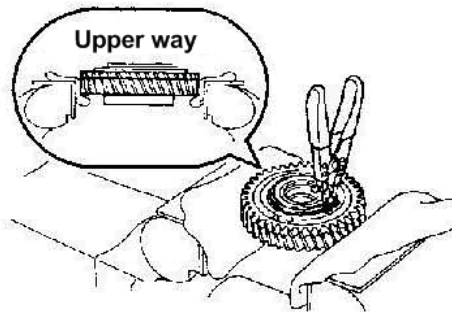

REMARK:

Make sure not to damage the toothed wheels during this operation.

g. Remove the snap ring with snap ring pliers.

h. Remove the following parts:

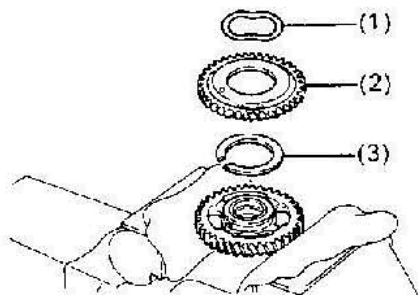

- (1) Star washer
- (2) No.2 secondary intermediate toothed wheel
- (3) Intermediate toothed wheel spring

CHECKING THE TOOTHED WHEEL TIMING

1. VERIFY INTERMEDIATE TOOTHED WHEELS

- a. Measure the inside diameter of each intermediate toothed wheel using a bore gauge.

Intermediate toothed wheel inside diameter:
44.000 – 44.025 mm

- b. Measure the outside diameter of the intermediate toothed wheel shaft using a micrometer.

Intermediate toothed wheel outside diameter:
43.965 – 44.000mm

- c. Subtract the external diameter measurement of the intermediate toothed wheel shaft from the internal diameter of the intermediate toothed wheel measurement.

Nominal lubrication clearance: **0.025 – 0.060 mm**
Lubrication clearance limit: **0.20 mm**

Replace the intermediate toothed wheel and its shaft when the lubrication clearance limit is exceeded.

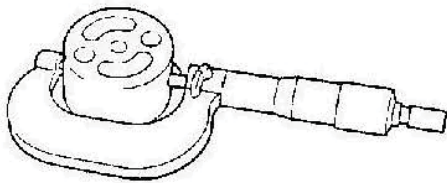
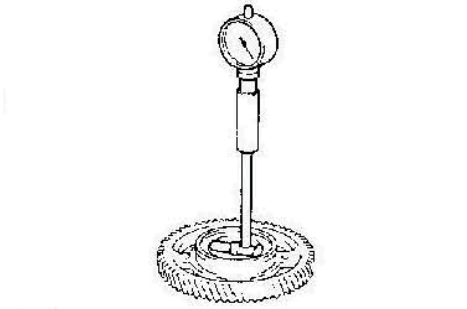

2. VERIFY THE INJECTION PUMP DRIVE GEAR BEARING

Verify that the bearing is not worn or seized.

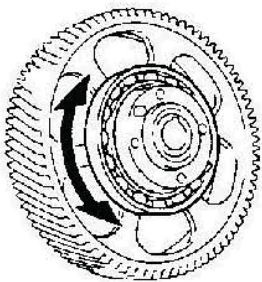

3. IF NECESSARY, REPLACE THE INJECTION PUMP DRIVE PINION BEARING

A. Remove the bearing

Use the special maintenance tool SST to remove the bearing.

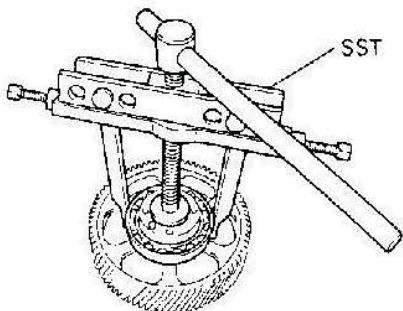

B. Reinstall the bearing

Use the special maintenance tool SST and a press to fit the bearing.

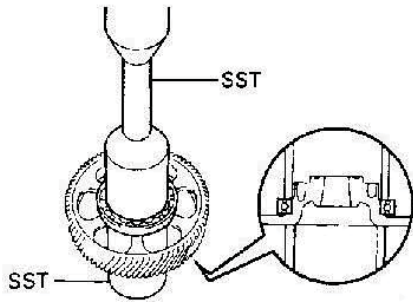

4. CHECK THE REACTIVE CLEARANCE OF THE TIMING TOOTHED WHEEL TEETH

Install the dial gauge to measure the teething reactive clearance between each toothed wheel of the timing.

Nominal teething reactive clearance: 0.02 – 0.15 mm

Teething reactive clearance limits: 0.20 mm

Replace the timing toothed wheel assembly by a matched assembly if the recorded clearance is greater than the limits stipulated in specifications.

Balancing shaft N°1 x Oil pump

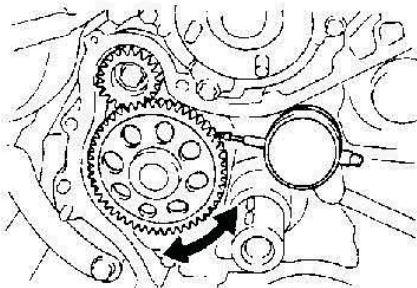

Balancing shaft N°2 x Injection pump

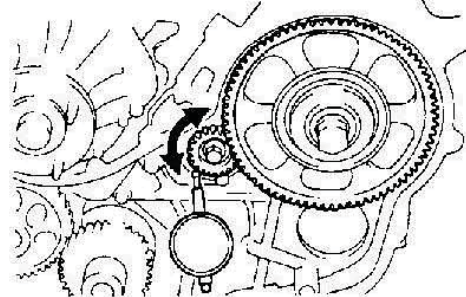

Crankshaft x Intermediate gear

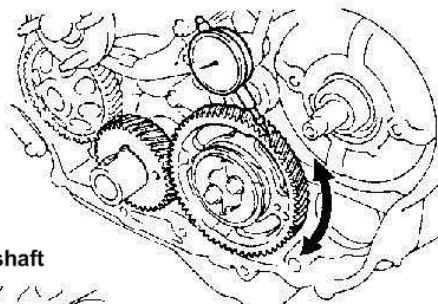

Oil pump and crankshaft

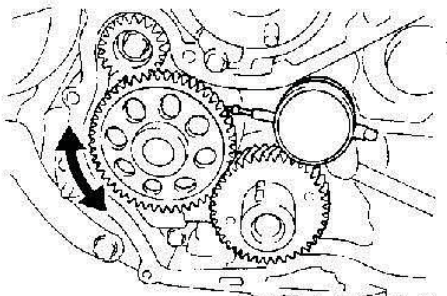

Injection pump X intermediate gear

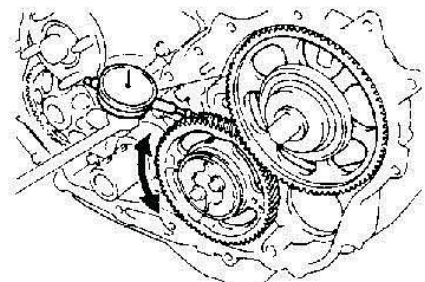

REPLACING THE CRANKSHAFT OIL GASKET

ADVICE:

There are two methods of replacing the oil gasket (A and B) as described below

REPLACE THE CRANKSHAFT OIL GASKET

A. When the timing casing cover is separate from the cylinder block:

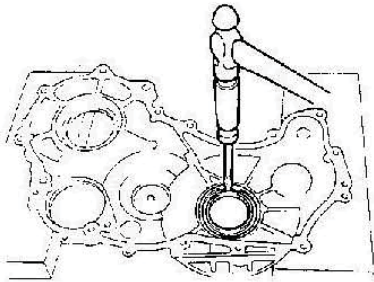

- a. Use a screw driver and a hammer to drive out the oil gasket.

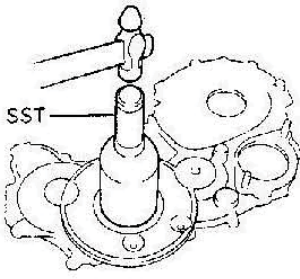

- b. Use special maintenance tool SST and a hammer to fit the new oil gasket. Enter the gasket until its surface is flush with the surface of the timing casing cover.
- c. Coat the oil gasket lip with grease MP.

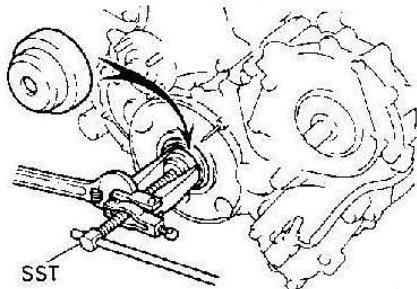

B. When the timing case cover is installed on the cylinder block:

- a. Use the special maintenance tool SST to drive out the oil gasket.

- b. Coat the lip of the new oil gasket with grease MP.

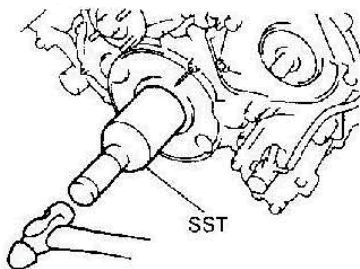

- c. Use special maintenance tool SST and a hammer to fit the new oil gasket. Enter the gasket until its surface is flush with the surface of the timing casing cover.

REPLACING THE INJECTION PUMP OIL SEAL

WARNING:

There are two methods of replacing the oil gasket (A and B) as described below

REPLACE THE INJECTION PUMP PINION OIL GASKET

A. When the timing casing cover is separate from the cylinder block:

- a. Use a screw driver and a hammer to drive out the oil gasket.
- b. Use special maintenance tool SST and a hammer to fit the new oil gasket. Enter the gasket until its surface is flush with the surface of the timing casing cover.
- c. Coat the oil gasket lip with grease MP.

B. When the timing case cover is installed on the cylinder block:

- a. Use the special maintenance tool SST to drive out the oil gasket.

REMARK: Make sure not to damage the injection pump drive pinion. Coat the end of the screwdriver with adhesive tape.

- b. Coat the lip of the new oil gasket with grease MP.
- c. Use special maintenance tool SST and a hammer to fit the new oil gasket. Enter the gasket until its surface is flush with the surface of the timing casing cover.

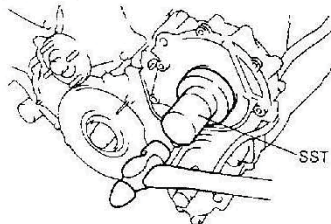
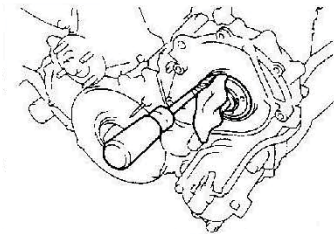
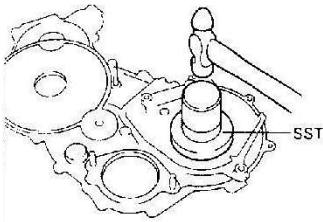
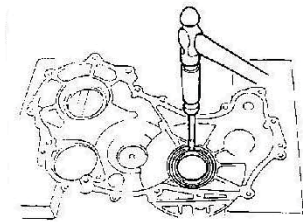

REINSTALLING THE TIMING PINIONS

(Refer to component part illustration for disassembly and reassembly)

1. REMOVE THE INTERMEDIATE TOOTHED WHEEL

- a. Install the intermediate toothed wheel in a vice.

WARNING:

Install the intermediate toothed wheel making sure to direct the marking notch downwards.

REMARK:

Make sure not to damage the toothed wheel during this operation.

- b. Reinstall the following parts:

- (1) Intermediate toothed wheel spring
- (2) No.2 secondary intermediate toothed wheel
- (3) Star washer

ADVICE:

Make the pawls of the toothed wheels coincide with the spring ends.

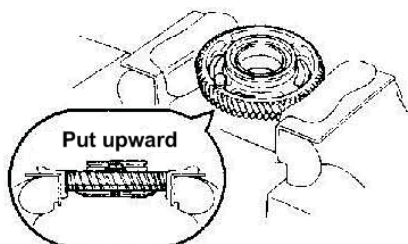
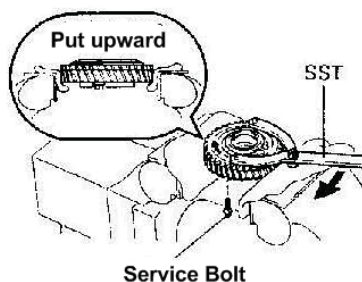
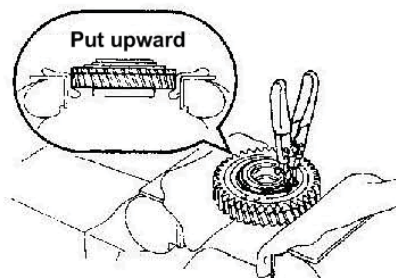
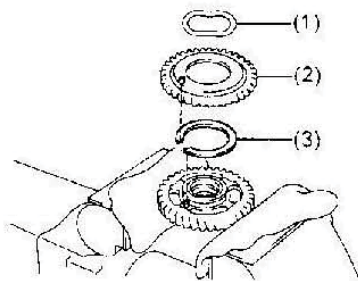
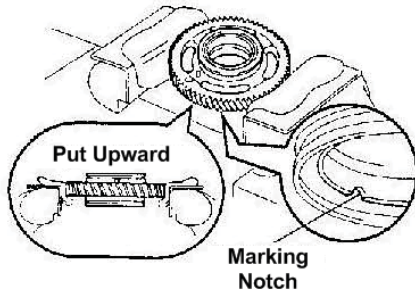

- c. Remove the snap ring with snap ring pliers.

- d. Use the special maintenance tool SST to make the holes in the intermediate toothed wheel and the No.2 secondary intermediate toothed wheel coincide by turning the No.2 secondary intermediate toothed wheel clockwise, then reinstall the service bolt.

- e. Remove the intermediate toothed wheel assembly from the vice and turn it over.

- f. Install the intermediate toothed wheel No.2 secondary intermediate toothed wheel in a vice.

REMARK:

Make sure not to damage the toothed wheels during this operation.

g. Remove the service bolt.

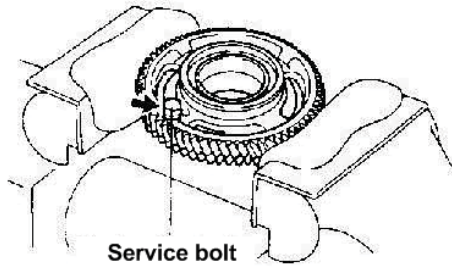

h. Reinstall the following parts:

- (1) Intermediate toothed wheel spring
- (2) No.1 secondary intermediate toothed wheel
- (3) Star washer

ADVICE:

Make the pawls of the toothed wheels coincide with the spring ends.

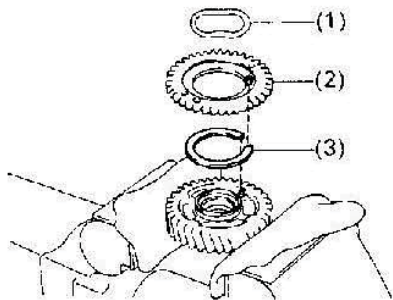

i. Reinstall the snap ring with snap ring pliers.

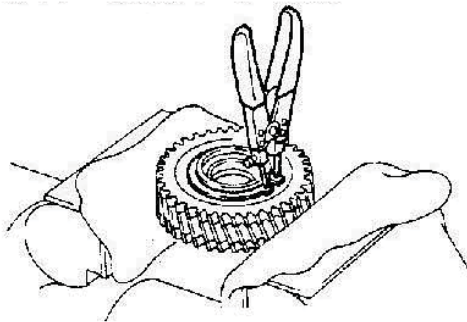

j. Use the special maintenance tool SST to make the holes in the intermediate toothed wheel and the No.1 secondary intermediate toothed wheel coincide by turning the No.2 secondary intermediate toothed wheel clockwise, then reinstall the service bolt.

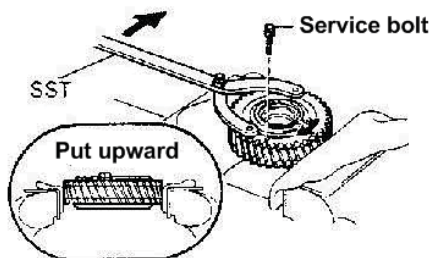

2. REINSTALL THE TIMING GEAR

REMARK:

* The alignment mark engraved on the surface of each toothed wheel is directed towards the front of the engine

* Make sure not to damage the teeth of the toothed wheels when removing and reinstalling toothed wheels.

Do not use scratched or damaged parts as they cause noise.

A. Reinstall the crankshaft timing toothed wheel

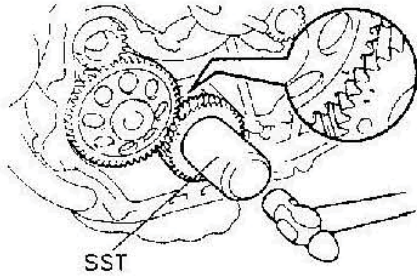

- Verify that the crankshaft assembly key is correctly positioned upwards to reinstall the crankshaft timing toothed wheel on the crankshaft.
- When this is done, the alignment marks of the oil pump shaft drive toothed wheel and the tooth wheel must correspond to position "1".
- Use the special maintenance tool SST and a hammer to fit the timing toothed wheel.

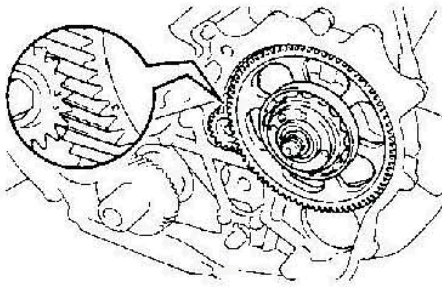

B. Reinstall the injection pump drive pinion

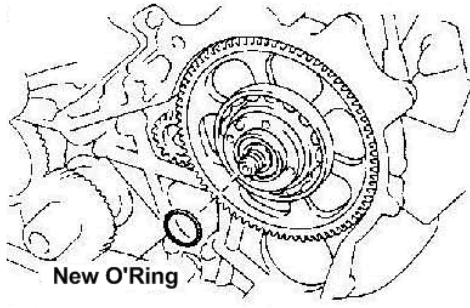

- Put the assembly key in the front of the injection pump shaft groove.
- The alignment marks of the driven toothed wheel of the No.2 balancing shaft must be in the same alignment as item "3".

- Reinstall a new o-ring on the injection pump drive pinion.

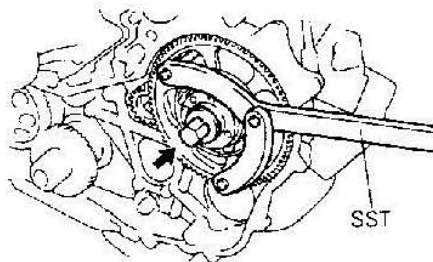

- Reinstall the injection pump drive pump attachment nut.
- Use the special maintenance tool SST to tighten the attachment nut to the recommended torque.

Recommended tightening torque: 64 N.m (650 kgf.cm)

C. Reinstall the intermediate toothed wheel

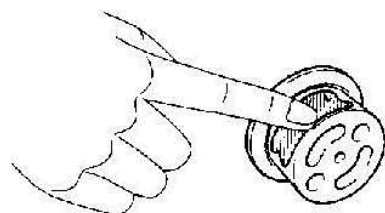

- Coat the intermediate toothed wheel shaft with engine oil at the locations indicated in the figure opposite.

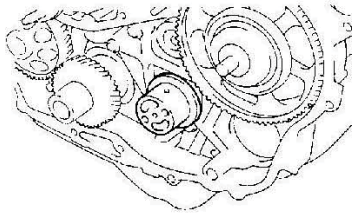

b. Reinstall the cylinder block intermediate toothed wheel shaft.

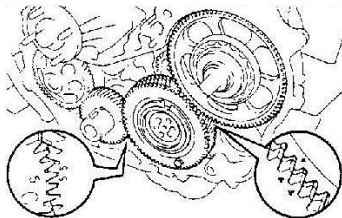

c. Make the timing adjustment marks "5" and "4" of the intermediated toothed wheel assembly, coincide respectively with the timing setting mark "5" of the crankshaft and the timing setting mark "4" of the injection pump drive pinion then engage timing toothed wheels mesh.

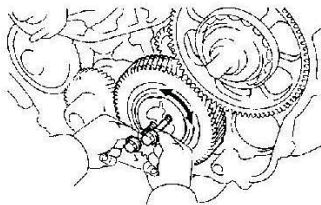

d. Make the stop washer assembly bolt holes coincide.

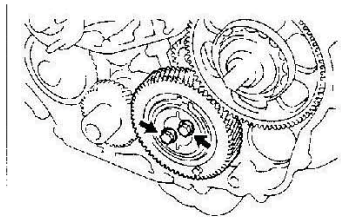

e. Reinstall the stop washer using the two assembly bolts. Tighten the bolts to the recommended tightening torque.

**Recommended tightening torque:
19 N.m (195 kgf.cm)**

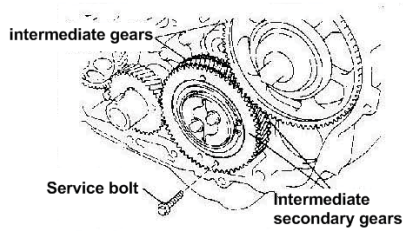

f. Remove the service bolt.

3. REINSTALL THE TIMING CASING COVER

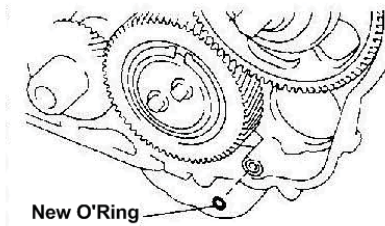

- a. Reinstall a new o-ring on the timing casing cover
- b. Carefully remove any signs of former sealant (FIPG) from application surfaces and take care not to dirty the assembly surfaces between the timing casing cover and the cylinder block.

* Carefully remove any signs of former sealant (FIPG) from application surfaces of the gasket and the sealing groove using a razor blade and scraper designed for this purpose.

* Carefully clean all removed parts to eliminate any signs of the product.

* Clean the two sealing surfaces using a residue-free solvent.

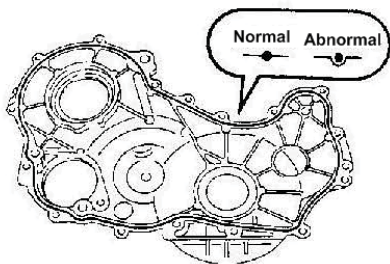

- c. Apply a bead of sealant on the timing casing cover working in the manner illustrated in the figure opposite

* Put a nozzle on the tube already cut to make a 2 to 3 mm opening

* Parts must be assembled within 5 minutes of applying the product, otherwise the sealant must be completely removed and applied again.

* Immediately remove the nozzle from the tube and screw back the closing cap.

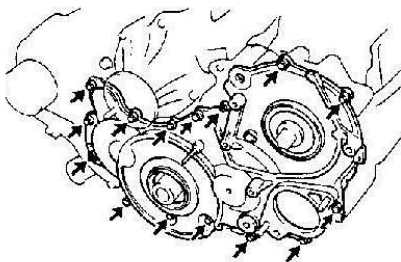

- d. Reinstall the timing casing cover using the thirteen assembly bolts and the two attachment nuts.

**Recommended tightening torque:
13 N.m (130kgf.cm)**

4. CHECK THE AXIAL CLEARANCE OF THE INJECTION PUMP DRIVE GEAR

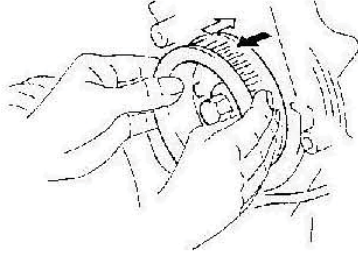

- a. Temporarily remove the flange and the No.2 cam shaft timing pulley with the four assembly bolts.
- b. Move cam shaft No.2 timing pulley from the front to the back and check the axial clearance of the injection pump pinion shaft.

Reference: 0.15 – 0.55 mm

If the axial clearance is insufficient, loosen the two attachment nuts of the injection pump and the three spacer assembly bolts securing the injection pump, and re-tighten them as necessary to obtain the necessary clearance.

If the axial clearance is still insufficient, remove the timing casing cover and reinstall it.

5. REINSTALL THE CRANKSHAFT PULLEY

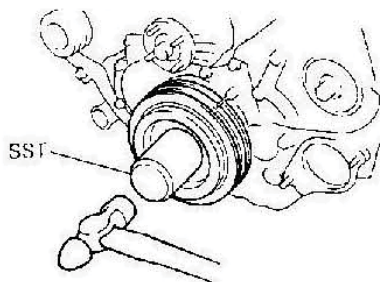

- a. Make the pulley assembly key coincide with the key groove in the pulley.
- b. Use the special maintenance tool SST and a hammer to fit the pulley.

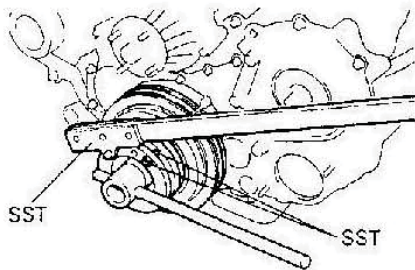

- c. Use the special maintenance tool SST to reinstall and tighten the pulley assembly bolt plate to the recommended tightening torque.

**Recommended tightening torque:
363 N.m (3.700 kgf.cm)**

6. REINSTALL THE SEA WATER PUMP

Recommended tightening torque:
21 N.m (210 kgf.cm)

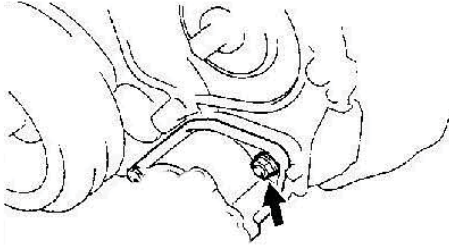

7. REINSTALL THE CAM SHAFT OIL GASKET RETAINER

Reinstall the cam shaft oil gasket retainer with the seven assembly bolts.

Recommended tightening torque:
9 N.m (90 kgf.cm)

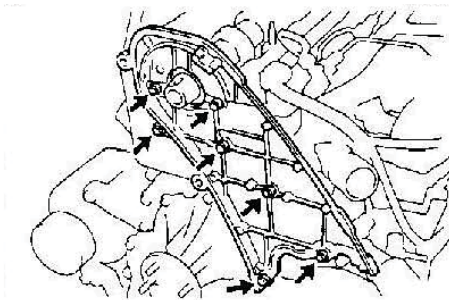

8. REINSTALL THE TIMING BELT AND THE PULLEYS

**REFER TO THE MAINTENANCE MANUAL FOR REINSTALLATION
AND SETTING OF THE TIMING BELT**

CYLINDER HEAD

Component part (removal and reinstallation)

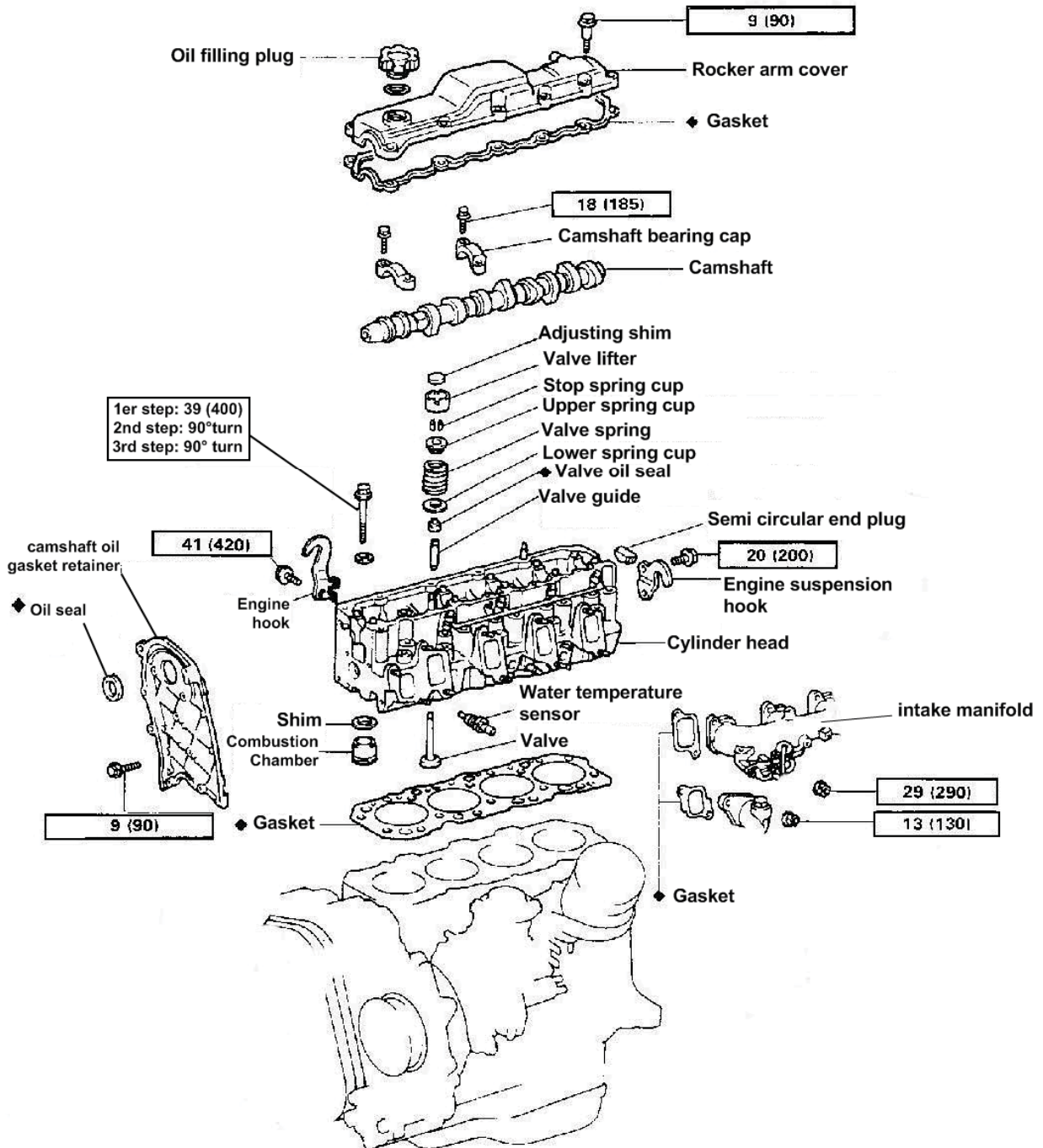

N.m (kgf.cm) : Specified tightening torque

◆ Non reusable part

REMOVE THE INTAKE MANIFOLD

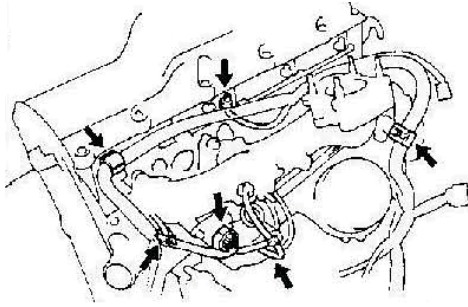

- a. Disconnect the following wiring connection block
 - * Water temperature sender gauge wiring connection block
- b. Disconnect the flexible pipe from the injection pump.
- c. Remove the rubber insulating washer, the attachment nut and the cable.
- d. Remove the two electrical wire harness attachments of the engine

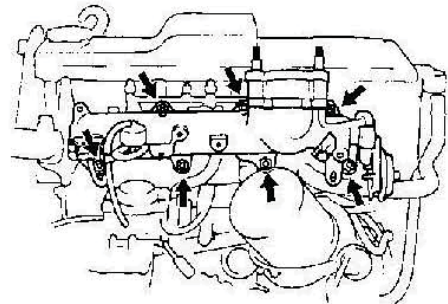
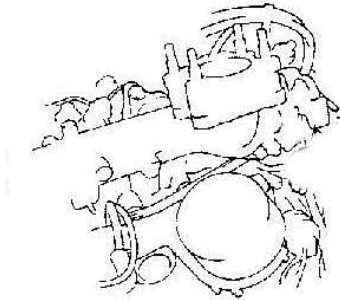

- e. Remove the seven attachment nuts, the intake manifold and the four seals

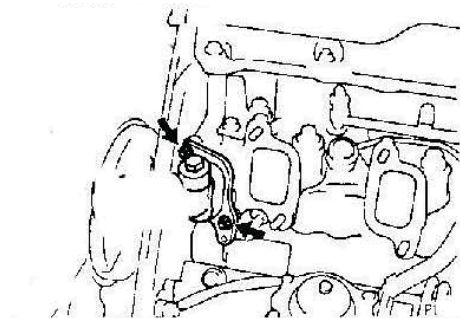

REMOVE THE WATER DISCHARGE PIPE

Remove the two attachment nuts, the water discharge pipe and the gasket

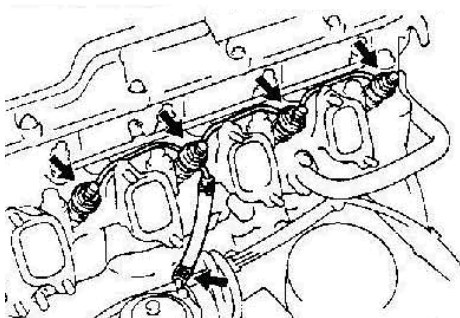

REMOVE THE INJECTOR RETURN PIPE

- a. Disconnect the flexible feeder pipe from the return pipe.
- b. Remove the four coupling attachment nuts, the injector drop pipe and the four seals.

REMARK:

* This engine is fitted with ceramic glow plugs. To prevent damaging the glow plugs, do not remove them unless it is absolutely necessary.

* Before removing the glow plugs, refer to the page in this manual discussing how glow plugs must be handled.

DRAIN THE ENGINE COOLANT.

REMOVE THE INTAKE PIPE.

REMOVE THE OIL LEVEL GAUGE AND ITS GUIDE

- a. Remove the attachment nut and the oil level gauge guide assembly.
- b. Remove the guide o-ring from the oil level gauge.

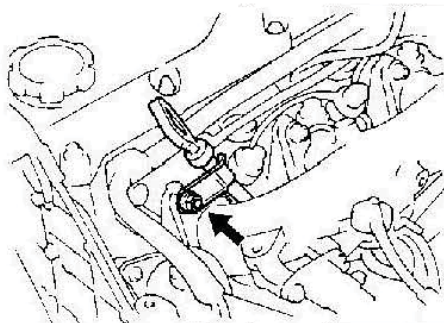

REMOVE THE INJECTORS

Remove the four injectors, the seals and the seats using special maintenance tools SST.

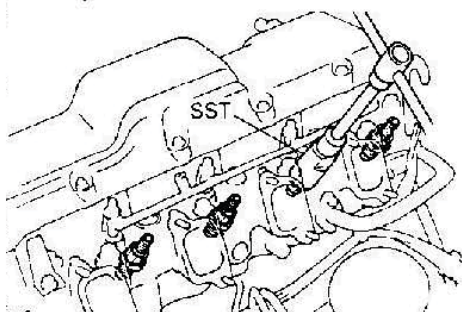

ADVICE: Lay the injectors down in the logical order corresponding to the cylinders.

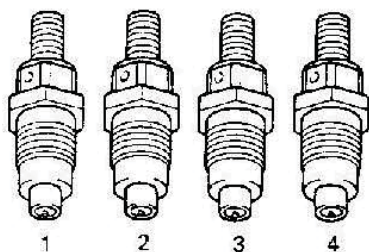

REMOVE THE TURBO CHARGER ASSEMBLY AND THE EXHAUST PIPE

REMOVE THE TIMING BELT AND THE PULLEYS

REMOVE THE CAM SHAFT OIL SEAL RETAINER

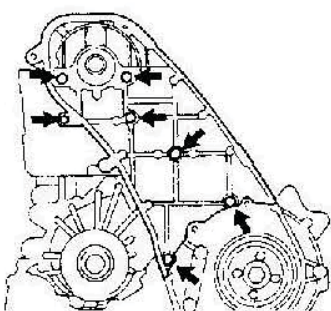

- a. Remove the seven assembly bolts securing the camshaft oil seal retainer to the cylinder head.
- b. Remove the cam shaft oil seal retainer to separate it.

REMOVE THE CAMSHAFT

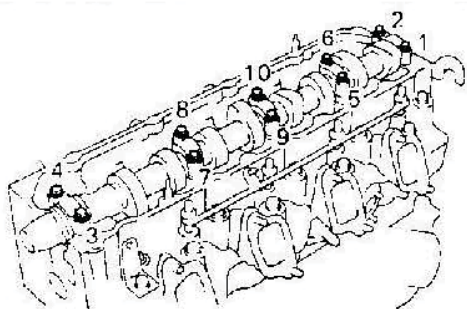

- a. Uniformly loosen and remove the ten bearing cap assembly bolts in several stages and in compliance with the order illustrated opposite.
- b. Remove the camshaft and the five bearing caps.

ADVICE:

Lay down the bearing caps in the exact order.

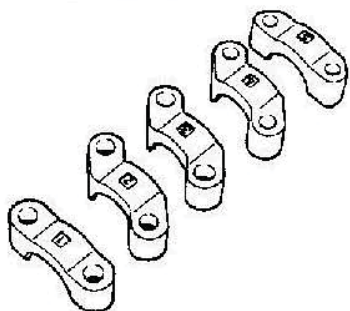

REMOVE THE CYLINDER HEAD

- a. Uniformly and gradually loosen the eighteen cylinder head bolts in several stages and in the order indicated on the illustration.

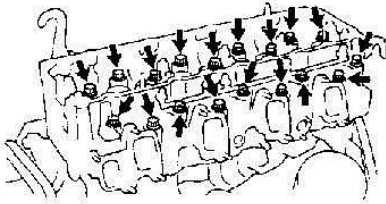

REMARK: Cylinder head warping or cracking may occur if the bolts are not loosened and removed in the indicated order.

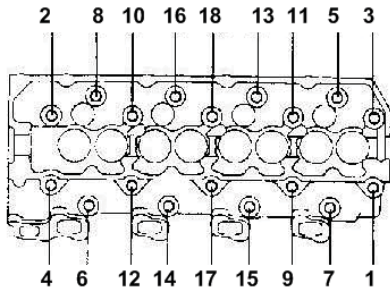

- b. Lift the cylinder head to separate it from the cylinder block positioning studs and put the cylinder head on wooden blocks placed on the bench.

ADVICE:

If the cylinder head is difficult to separate, prise with a screwdriver pushed between the cylinder block and the cylinder head.

REMARK:

Pay attention not to damage the assembly surfaces of the cylinder head and the cylinder block, especially close to cylinders and the surface accommodating the cylinder head gasket.

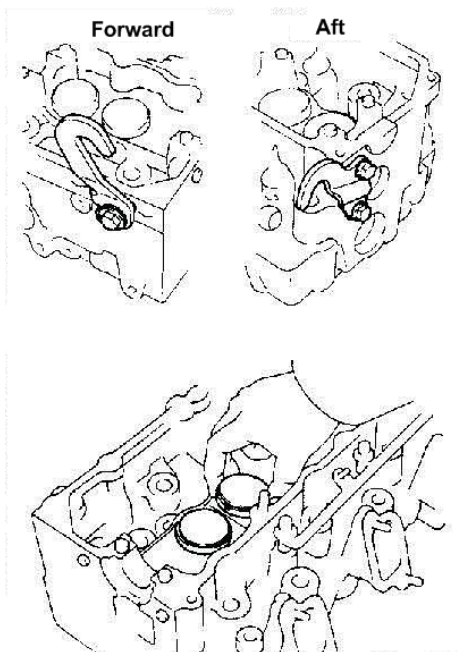
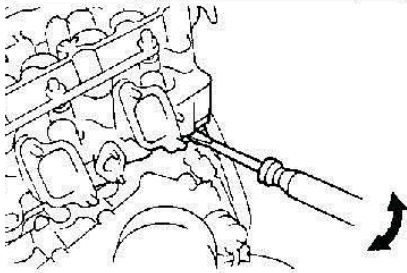

REMOVING THE CYLINDER HEAD

(Refer to component part illustration for disassembly and reassembly)

1. REMOVE THE FRONT AND REAR SUSPENSION HOOKS OF THE ENGINE
2. REMOVE THE CABLE ATTACHMENT PLATE
3. REMOVE THE WATER TEMPERATURE SENDER GAUGE
4. REMOVE THE VALVE LIFTERS WITH THE RELATED THICKNESS SHIMS

ADVICE:

Remove the valve lifters and thickness shims in the disassembly order.

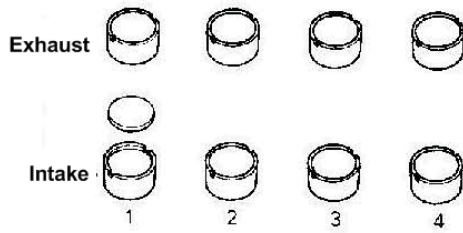

REMOVE VALVES

- a. Compress valve springs using special maintenance tool SST and remove the two half-keys.
- b. Remove the spring cup retainer, the valve spring, the valve and the valve cup.

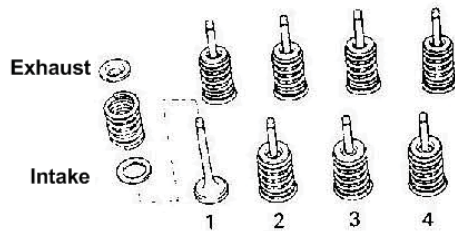
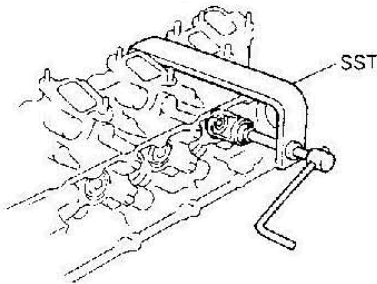

ADVICE:

Remove valves, valve spring cups and spring cup keys in the disassembly order.

- c. Use long-nosed pliers to remove oil seals.

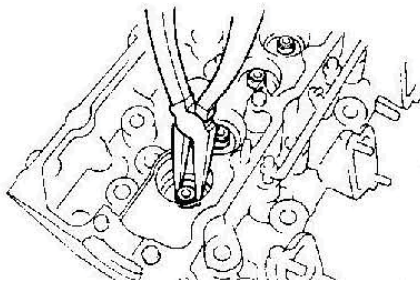

REMOVE THE COMBUSTION CHAMBERS

Use special maintenance tool SST to remove the four cylinder head combustion chambers.

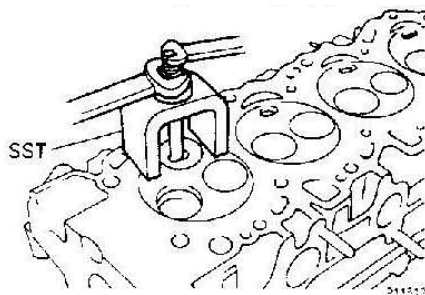

ADVICE: Lay out the combustion chambers in the logical disassembly order.

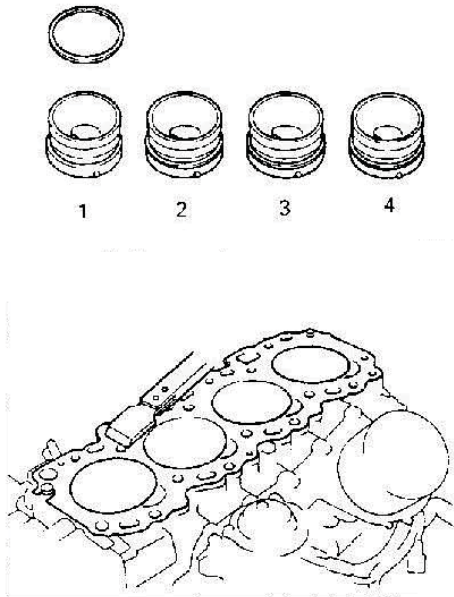

REMOVE THE SEMI-CIRCULAR CAP

CHECKING, MAINTENANCE AND RECONDITIONING OF COMPONENT PARTS OF THE CYLINDER HEAD

1. CLEAN THE TOP OF THE PISTON AND THE TOP SURFACE OF THE CYLINDER BLOCK

- a. Rotate the crankshaft so as to bring each piston to top dead center. Use a gasket scraper to carefully remove all signs of carbon deposits accumulated on the tops of pistons.
- b. Also remove any particles of sealant from the surface of the cylinder block.

REMARK: take care not to scratch the surfaces.

- c. Eliminate accumulation of carbon deposits and oil in bolt holes with compressed air.

PRECAUTION: Protect your eyes when cleaning with a powerful jet of compressed air on these parts.

2. CLEAN THE CYLINDER HEAD

A. Remove pieces of gasket

Use a gasket scraper to remove any signs of sealant on the cylinder block surface.

REMARK:

Take care not to scratch the contact surfaces of the cylinder block.

B. Clean the combustion chambers

Remove carbon deposits from combustion chambers using a metal brush.

REMARK:

Take care not to damage the contact surface of the cylinder block.

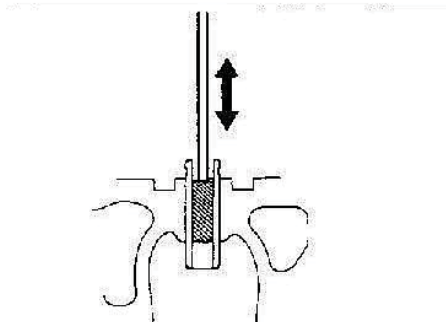

C. Clean valve guide bushes

Use a valve guide bush brush and a solvent to carefully clean the valve guide bushes.

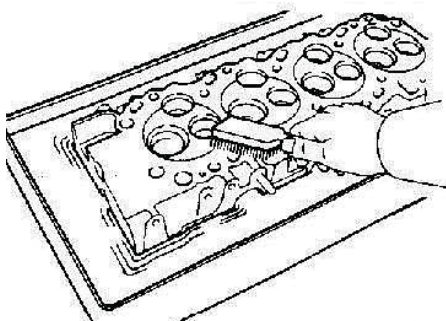

D. Clean the cylinder head

Use a flexible bristle brush and solvent to carefully clean the cylinder heads.

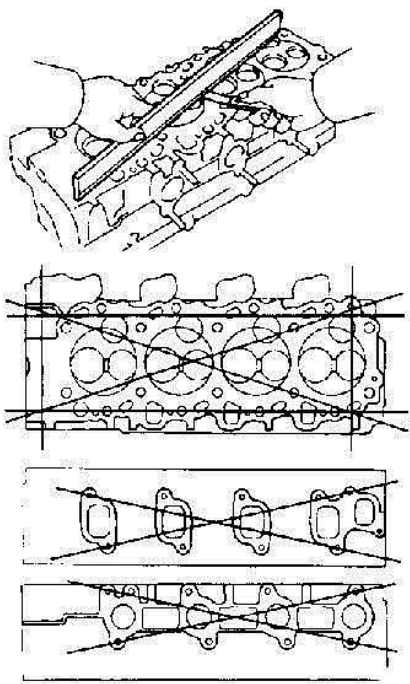

3. CHECKING THE CYLINDER HEAD

A. Check flatness

Use a precise straight edge and a set of thickness shims to measure the contact clearance of the surface between the cylinder block and the manifolds, and to detect any possible warping.

Maximum warping: 0.15 mm

If warping is higher than the maximum dimension, replace the cylinder head.

B. Check for cracks

Use a dye and examine the combustion chambers, intake slots, exhaust slots and the cylinder block surface to detect any cracks. Replace the cylinder head if cracks are found

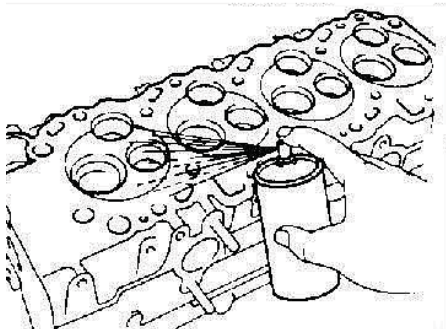

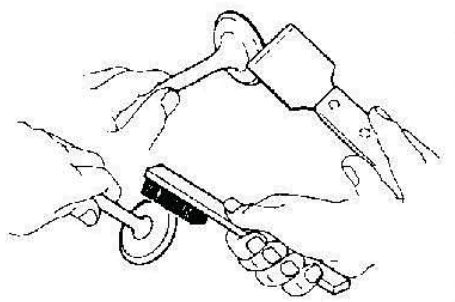

4. CLEAN THE VALVES

- a. Use a gasket scraper to separate any accumulation of carbon deposits on the tops of valves.
- b. Use a metal brush to carefully clean valves.

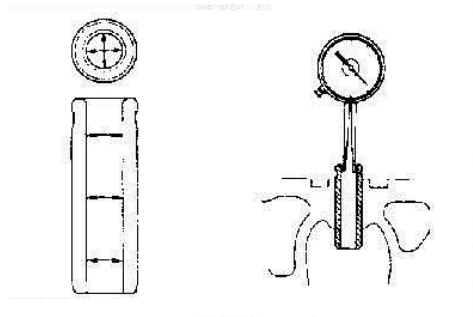

5. CHECK RODS AND VALVE GUIDES

- a. Measure the inside diameter of each valve guide using a micrometer.

Guide inside diameter: 8.010 – 8.030 mm

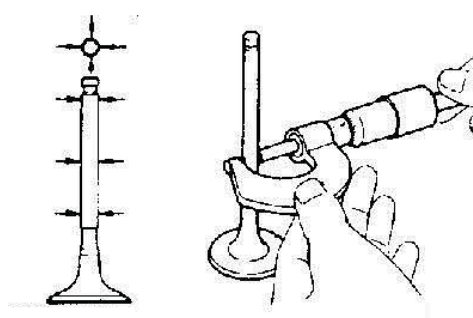

- b. Use a micrometer to measure the diameter of valve stems.

Valve stem diameter:

Intake: 7.975 – 7.990 mm

Exhaust: 7.960 – 7.975 mm

- c. Subtract the measured value for the valve stem guide from the value of the external diameter of the valve guide bush.

Nominal oil clearance:

Intake: 0.020 – 0.055 mm

Exhaust: 0.035 – 0.070 mm

Oil clearance limit:

Intake: 0.08 mm

Exhaust: 0.10 mm

If the oil clearance is greater than the maximum limit, replace the valve and the guide bush involved.

6. IF NECESSARY, REPLACE VALVE GUIDE BUSHES

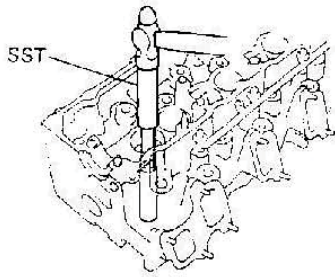

- a. Drive out the valve guide using the special maintenance tool SST and a hammer.

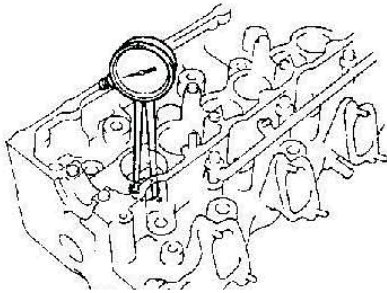

- b. Use an inside micrometer to measure the bore of the cylinder head valve guide bushes

- c. Select a new valve guide bush (nominal dimension or dimension greater by 0.05).

Same for the exhaust and intake valves

Guide bore in mm	Guide value
13.000 – 13.027	Use the nominal value
13.050 – 13.077	Use the value +0.05mm

If the diameter of the cylinder head valve guide bush bore is greater than 13.027 mm, grind the valve guide bush valve bore to the dimensions indicated below:

Re-bore dimension of the cylinder head valve guide bush:

13.050 – 13.077 mm

If the diameter of the cylinder head valve guide bush bore is greater than 13.077 mm, replace the cylinder head

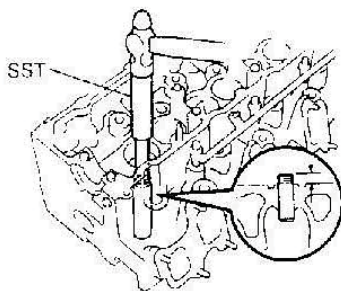

- d. Use the special maintenance tool SST and a hammer to fit the new valve guide in the cylinder head until the part flush with the cylinder head is between 12.8 and 13.2 mm.

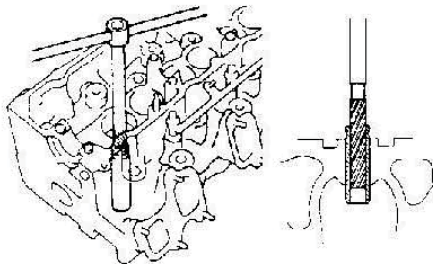

- e. Use an 8 mm diameter reamer and ream the valve guide bush to bring it to the specified nominal dimension.

Dimension measured between the valve guide and the new valve stem.

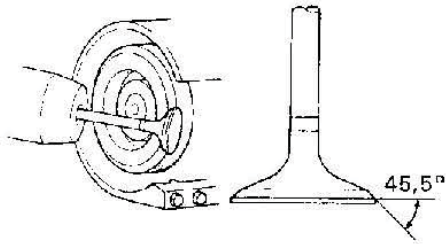

7. EXAMINE AND GRIND VALVES

- Only grind valves with an electric grinder if surface pitting or carbon deposits need to be removed.
- Make sure that the angle of the sealing surface of valves is ground to the indicated dimension.

Valve sealing surface angle: 45.5°

- Measure the thickness of the valve head.

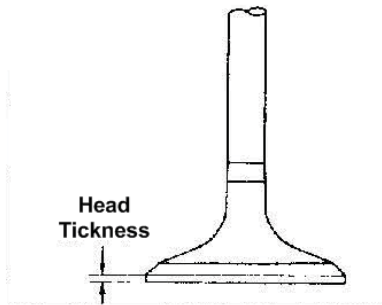

Nominal thickness of valve head:

Intake: 1.6 mm

Exhaust: 1.7 mm

Valve head minimum thickness:

Intake: 1.1 mm

Exhaust: 1.2 mm

If the thickness of the valve head is less than the minimum dimension, replace the valve involved

- Measure the overall length of the valves.

Nominal overall length of the valve:

103.29 – 103.69 mm

Minimum overall length of the valve: 102.79 mm

Replace the valve involved when the overall length of the valve is less than the minimum dimension.

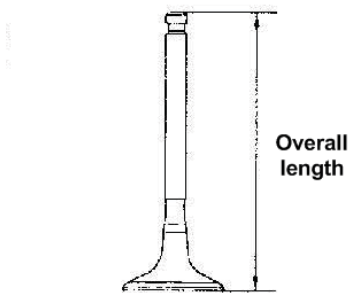

- Measure the degree of wear on the valve stem end.

Grind the end of the valve stem end with an electric grinder if worn, or replace the valve.

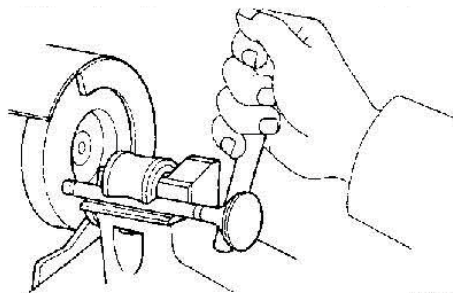

REMARK:

Make sure not to remove more material than necessary as it may no longer be possible to obtain the overall minimum length of the valve stem.

8. EXAMINE AND CLEAN THE VALVE SEATS

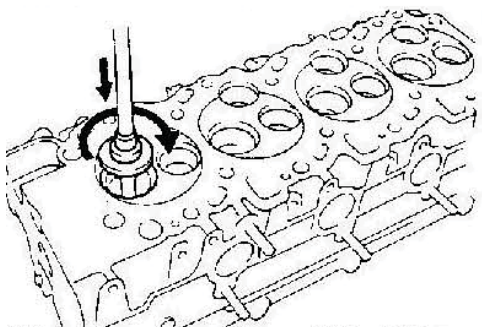
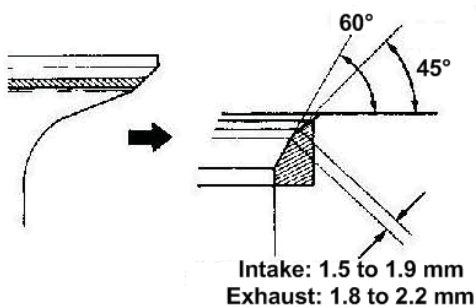
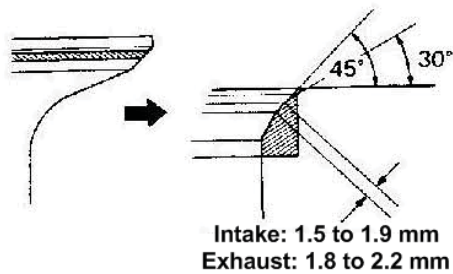
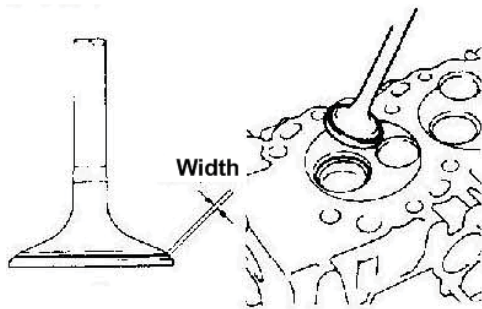
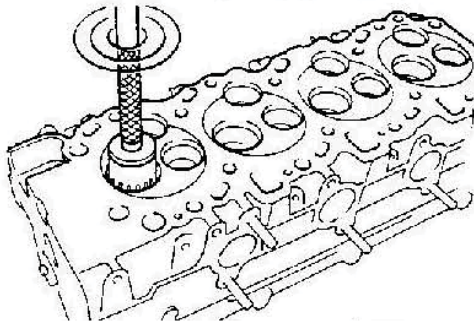

- a. re-bore the valve seats using a 45° carbide reamer and essentially remove the amount of material making it possible to return the seats to good condition.

- b. Check the bearing surface of the valve on its seat.

Apply a fine coat of the engineer blue (or white lead) on the surface of the valve. Fit the valve and apply moderate pressure to the valve. Do not rotate the valve on its seat

- c. Examine the surface of the valve and its seat to check for the following:

* If the blue is visible over 360° around the surface of the valve, this means that the valve is concentric. Replace the valve if it is not like this.

* If the blue appears over 360° on the surface of the valve seat, this means that the valve seat and guide are concentric. Re-bore the valve seat otherwise.

* Check that the contact of the valve surface is on the intermediate part of the seat and on the width indicated below:

Intake: 1.5 to 1.9 mm
Exhaust: 1.8 to 2.2 mm

Otherwise, grind the seat as follows:

1. If the contact is too high on the surface of the valve, use 30° and 45° milling tools to correct the seat.
2. If the contact is too low on the surface of the valve, use 60° and 45° milling tools to correct the seat.

- d. Lap the valve and its seat by hand using lapping compound.

- e. Remove all signs of lapping compound from the valve and its seat when the operation is finished.

9. CHECKING VALVE SPRINGS

Squaring check

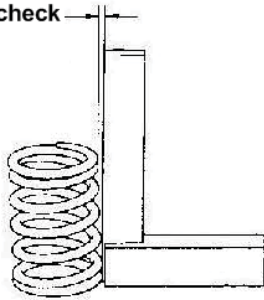

- a. Use a metal square to measure the squareness of the valve springs.

Squaring limit: 2.0 mm

Replace the valve spring if the maximum squaring is exceeded.

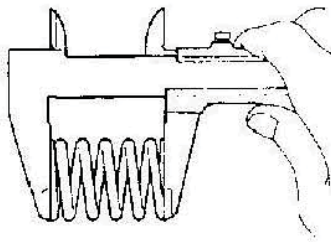

- b. Use a slide caliper to measure the length of the valve spring, not pressed.

Length not pressed: 48.54 mm

Replace the valve spring if the free length is not within the limits stipulated in specifications.

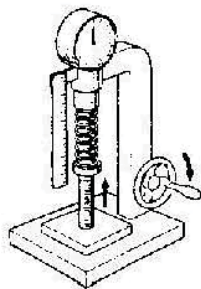

- c. Use a spring controller to measure the tension of the valve spring at the installed and specified length.

Installed spring tension:

301 – 332 N (30.7 – 33.9 kgf) over a 37.0 mm length

Replace the valve spring if the tension of the installed spring is not within the limits stipulated in specifications.

10. VERIFY BEARINGS AND CAMSHAFT

A. Verify out of roundness of the camshaft

- a. Install the cam shaft on V blocks.
- b. Use a dial gauge to measure the out of roundness of the center bearing.
- c.

Maximum out of roundness: 0.06 mm

If the out of roundness is greater than specifications, replace the cam shaft.

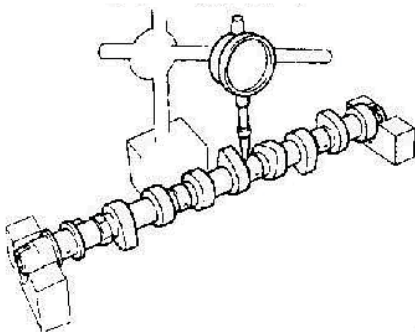

B. Checking the cam tops

Use a micrometer to measure the cam peaks.

Cam peak height:

Intake: 54.810 – 54.910 mm

Exhaust: 56.140 – 56.240 mm

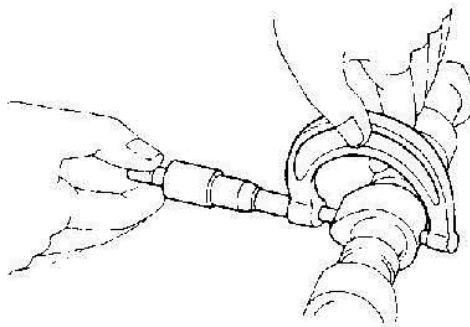

Minimum cam peak height:

Intake : 54.39 mm

Exhaust: 55.72 mm

Replace the camshaft if the height of the cam peak is less than the minimum limit.

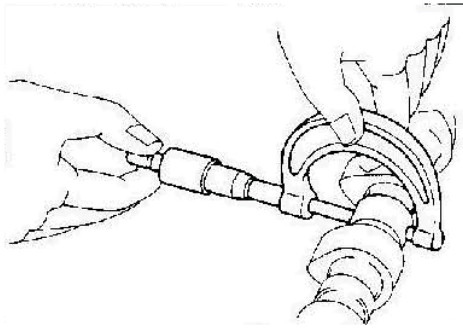

C. Check cam shaft pivot

Measure the diameter of the pivot using a micrometer.

Nominal diameter: 27.969 – 27.985 mm

Verify the lubrication clearance if the trunnion diameter is less than the indicated dimension

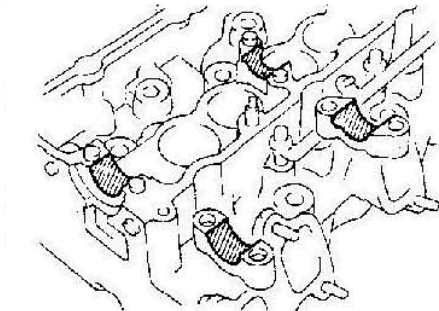

D. Check cam shaft bearings

Check for flaking and scratching on bearings. Replace bearing caps and the cylinder head as a matched pair if bearings are damaged.

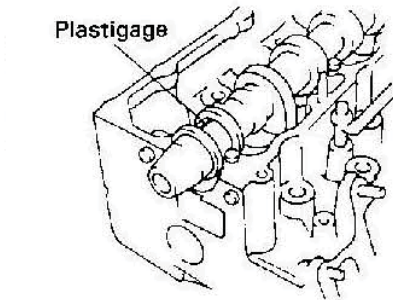

E. Check the lubrication clearance of the camshaft pivot

- a. Carefully clean the bearing caps and the cam shaft pivot.
- b. Install the cam shafts in the cylinder head.
- c. Spread a piece of plastigage across each pivot.
- d. Reinstall the bearing caps

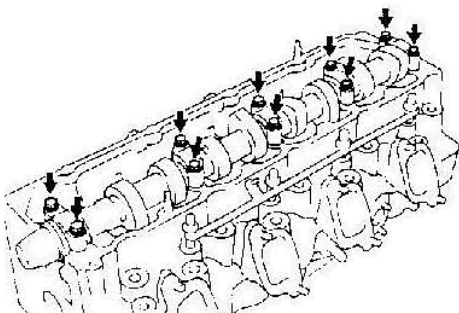

**Recommended tightening torque:
18 N.m (185 kgf.cm)**

**REMARK:
Make sure not to rotate the camshaft.**

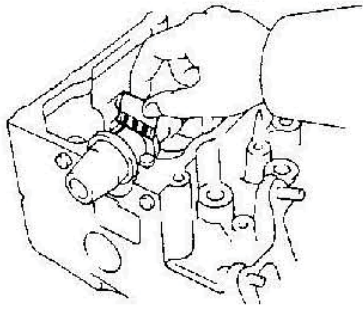

e. Remove the bearing caps.

f. Measure the widest part of the plastigage.

Nominal lubrication clearance: 0.025 – 0.062 mm
Lubrication clearance limit: 0.10 mm

Only replace the cam shaft if the maximum limit is exceeded. Replace bearing caps and the cylinder head as a matched pair if necessary.

g. Carefully remove all signs of the plastigage

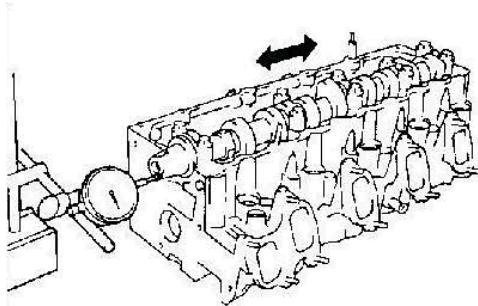

F. Check the cam shaft axial clearance

a. Reinstall the cam shaft.

b. Measure the cam shaft axial clearance with a dial gauge by moving the cam shaft from back to front.

Nominal axial clearance: 0.08 – 0.18 mm
Axial clearance limit: 0.25 mm

Replace the cam shaft if the axial clearance limit is greater than the limit recommended in specifications. If necessary, replace the bearing caps and the cylinder head as a matched pair.

11. CHECK THE VALVE LIFTERS AND THEIR BORES

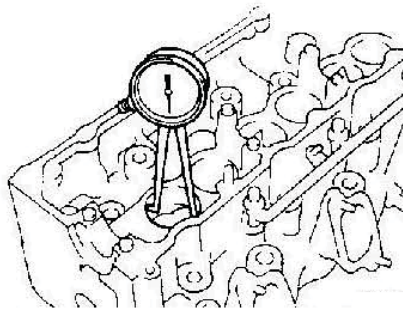

a. Measure the inside diameter of the cylinder head valve lifter bore using a dial gauge.

Lifter inside diameter: 40.930 – 40.950 mm

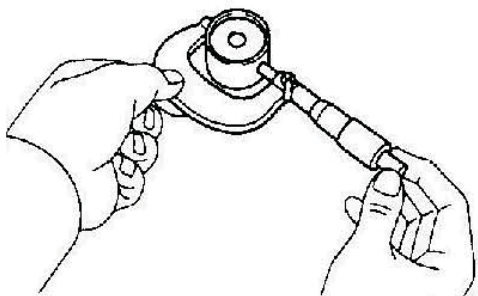

b. Measure the diameter of the valve lifter using a micrometer.

Valve lifter diameter: 40.892 – 40.902 mm

c. Subtract the valve lifter diameter measurement from the valve bore diameter.

Nominal lubrication clearance: 0.038 – 0.063 mm
Lubrication clearance limit: 0.08 mm

Replace the valve lifter if the lubrication clearance limit is exceeded. If necessary, replace the cylinder head.

12. CHECK INTAKE AND EXHAUST MANIFOLDS

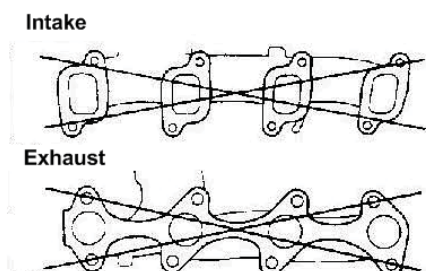

Use a ground straight edge and a set of thickness shims to verify the degree of warping of cylinder head contact surfaces.

Warping limit: 0.40 mm

If warping exceeds the limit stipulated in specifications, replace the manifold involved.

13. CHECK CYLINDER HEAD BOLTS

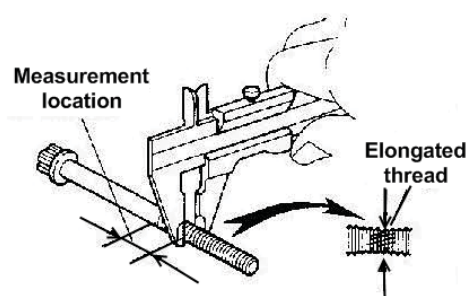

Use a slide caliper to measure the outside diameter of the compressed section of the bolt thread at the section to measure.

Nominal outside dimension: 11.8 – 12.0 mm
Minimum outside dimension: 11.6 mm

Replace the bolts with a diameter less than the minimum dimension.

REPLACING THE CAM SHAFT OIL GASKET

ADVICE:

There are two methods of replacing the oil gasket (A and B) as described below.

REPLACE THE CAM SHAFT OIL GASKET

A. When the cam shaft oil gasket retainer is taken off the cylinder head:

a. Use a screwdriver to drive out the oil gasket

b. Use special maintenance tool SST and a hammer to fit a new oil gasket until its surface is flush with the surface of the cam shaft oil gasket retainer.

c. Coat the oil gasket lip with grease MP.

B. When the cam shaft oil gasket retainer is installed on the cylinder head:

a. Use a screwdriver to prise out the oil gasket, then remove it.

REMARK:

Take care not to damage the cam shaft. Coat the end of the screwdriver with adhesive tape.

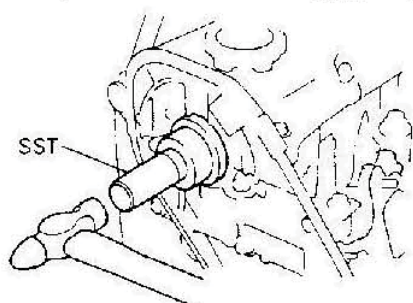
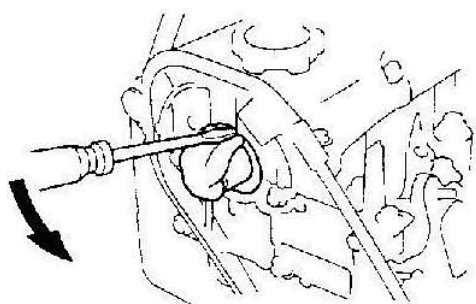
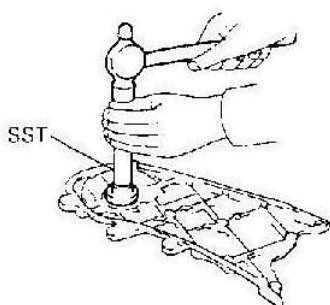
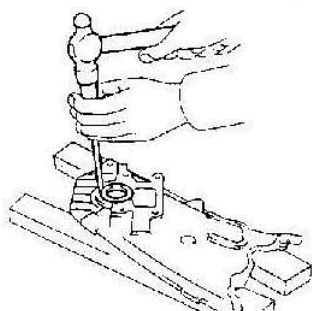

b. Coat the lip of the new oil gasket with grease MP.

c. Use special maintenance tool SST and a hammer to fit a new oil gasket until its surface is flush with the surface of the cam shaft oil gasket retainer.

REINSTALL THE CYLINDER HEAD

(Refer to the component part illustration for disassembly and reassembly)

ADVICE:

- * Carefully clean all parts to assemble.
- * Before starting to assemble the parts, coat all rotating and sliding surfaces with fresh engine oil.
- * Reinstall new oil seals and rings.

1. CHOOSE THE COMBUSTION CHAMBER THICKNESS SHIMS

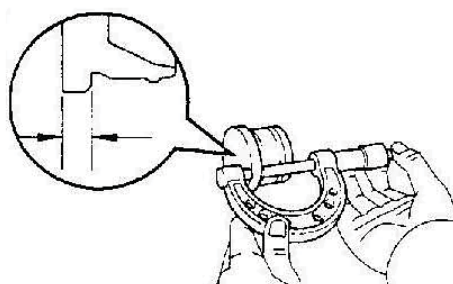

A. When a new combustion chamber is used:

- a. Use a micrometer to measure the thickness of each combustion chamber at the location shown on the figure opposite.
- b. Measure the thickness of the new combustion chamber as indicated in (a).
- c. Take the thickness of the new combustion chamber and subtract the thickness of the former combustion chamber to be able to select an appropriate thickness shim from amongst those listed in the table below.

Difference in thicknesses of combustion chambers:

Thickness of the new combustion chamber – thickness of the former combustion chamber in mm

Difference in combustion chamber thickness mm	Thickness of the thickness shim to use mm
Plus 0.02 – less 0.02	No thickness shim is necessary
Less 0.03	0.05 or no thickness shim is necessary
Less 0.04 – less 0.07	Less 0.05
Less 0.08	0.05 or 0.10
Less 0.09 – less 0.12	0.10

REMARK:

Do not install two 0.05 mm thickness shims instead of one 0.10 mm thickness shim.

B. When the combustion chamber is re-used:

Reposition the combustion chamber in its original position.

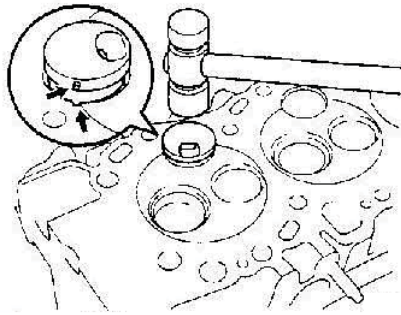

2. REINSTALL THE COMBUSTION CHAMBERS

- a. Make the combustion chamber position pin coincide with the corresponding recess in the cylinder head.
- b. Use a plastic mallet to fit the combustion chambers and position them.

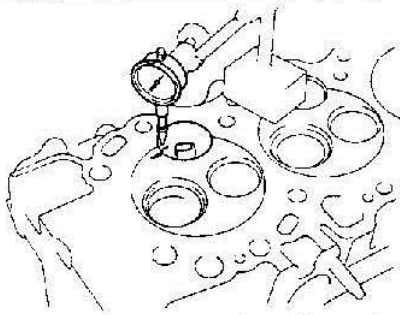

- c. Use a dial gauge to verify the amount the combustion chambers protrude.

**Combustion chamber protrusion:
Less 0.03 – plus 0.02 mm**

If the protrusion of the combustion chamber is less than the specified dimension, obtain this dimension with thickness shims.

Thickness shim thickness: 0.05 mm/0.10 mm

If the protrusion of the combustion chamber is less than the specified dimension, replace the combustion chamber, then check the amount of protrusion again.

3. REINSTALL VALVES

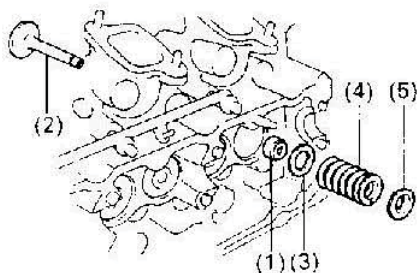

- a. Reinstall the following parts:

1. Oil gasket
2. Valve
3. Spring cup
4. Valve spring
5. Spring key

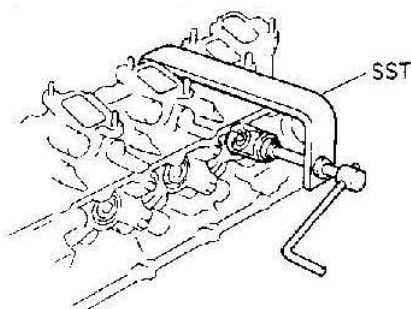

- b. Compress the valve springs using special maintenance tool SST and reinstall the two half-keys against the valve stem.

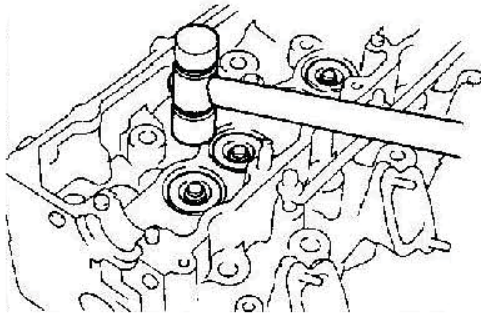

- c. Lightly strike the end of the valve stem with the plastic mallet to verify that it is correctly positioned.

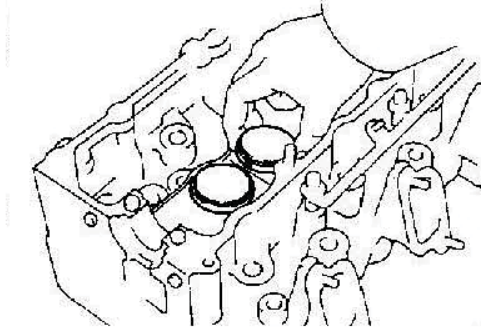

4. REINSTALL THE VALVE LIFTERS WITH THEIR THICKNESS SHIMS

- Reinstall the valve lifters and thickness shims.
- Check that the valve lifters turn normally when moved by hand.

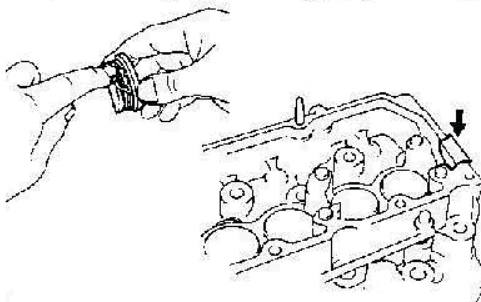

5. REINSTALL THE WATER TEMPERATURE SENDER GAUGE

6. REINSTALL THE CABLE ATTACHMENT PLATE

7. REINSTALL THE SEMI-CIRCULAR CAP

- remove signs of former gasket
- Coat the edge of the semi-circular cap with sealant, working as illustrated in the figure opposite.
- Install the semi-circular cap on the cylinder head.

8. REINSTALL THE ENGINE FRONT AND REAR SUSPENSION HOOKS

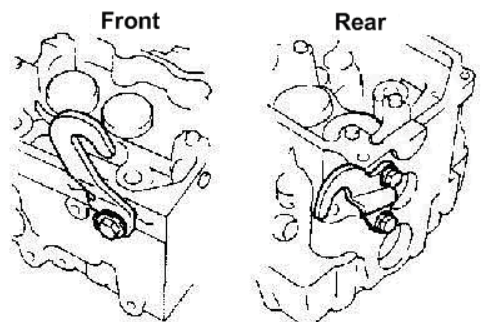

Recommended tightening torque:

Front: 41 N.m (420 kgf.cm)

Rear: 20 N.m (200kgf.cm)

REINSTALLING THE CYLINDER HEAD

1. VERIFY THE PROTRUDING PART OF THE PISTON AND CHOOSE THE CORRESPONDING CYLINDER HEAD GASKET

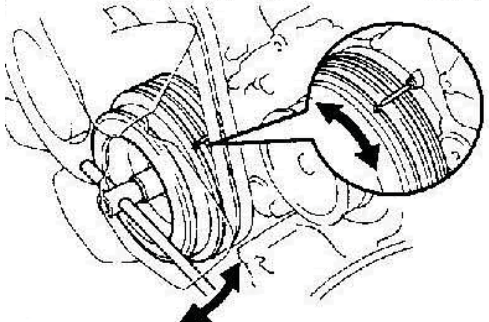
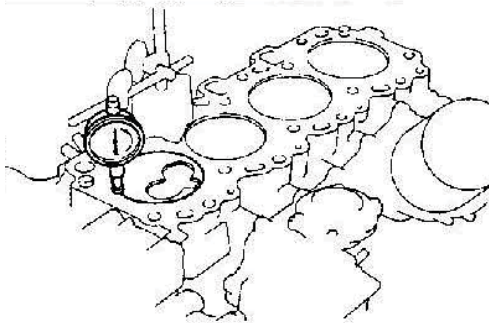

- A. Verify the protruding part of the piston of each cylinder.
- Carefully clean the cylinder block assembly surface with a grease remover.
 - Position the cylinder so as to measure a location just before top dead center pressure (TDC)
 - Install a dial gauge on the cylinder head and adjust the dial gauge to 0 mm.

ADVICE:

- * Use the dial gauge with a sensor as shown on the figure opposite.
- * Verify that the sensor is perpendicular to the surface of the cylinder block gasket and the piston head.

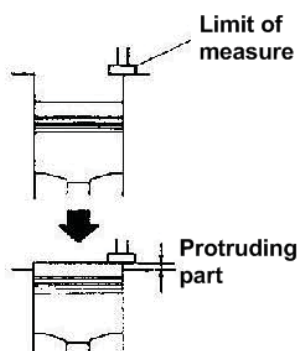
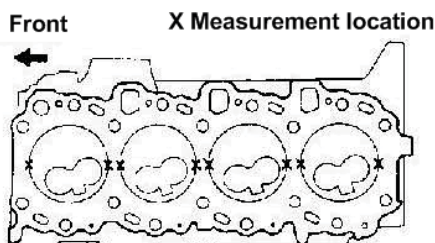

- Find the position corresponding to the greatest percentage of piston head protrusion by slowly rotating the crankshaft in a clockwise direction or in a counter-clockwise direction.
- The measurement must be made at two different locations for each cylinder, proceeding as illustrated in the figure opposite.
- Using the piston protrusion percentage measurements made on each cylinder, select the average value of two measurements for each cylinder.

Protrusion: 0.08 – 0.33 mm

(When a piston-connecting rod assembly is removed)
If the piston head protrusion value is not within the limits recommended by the specifications, remove the piston-connecting rod assembly and reinstall it.

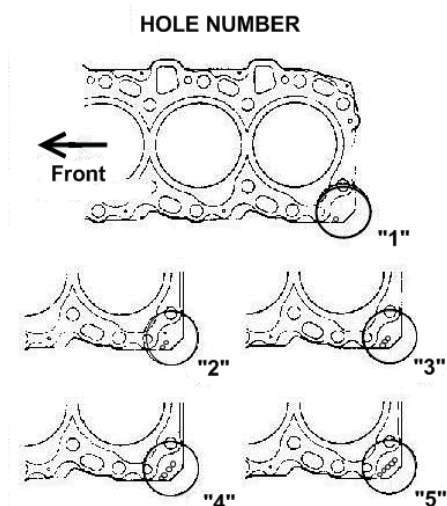

B. Select a new cylinder head gasket.

ADVICE:

There are 5 types of cylinder head gaskets (hole No.1 to 5) which are installed in the factory but only 3 types as procurement parts (hole No. "1", "3", and "5") so that when replacing a cylinder head gasket, the choice of the new gasket must be from amongst these 3 types proposed.

Thickness of the cylinder head gasket installed:

Hole No. "1": 0.80 – 0.90 mm
 Hole No. "3": 0.90 – 1.00 mm
 Hole No. "5": 1.00 – 1.10 mm

Using the piston protrusion percentage measurements made on each of the cylinders, select the most appropriate value and then choose the appropriate cylinder head gasket in compliance with the information given in the table below.

Piston protrusion mm	Gasket size
0.08 – 0.12	Use gasket No. "1"
0.13 – 0.22	Use gasket No. "3"
0.23 – 0.33	Use gasket No. "5"

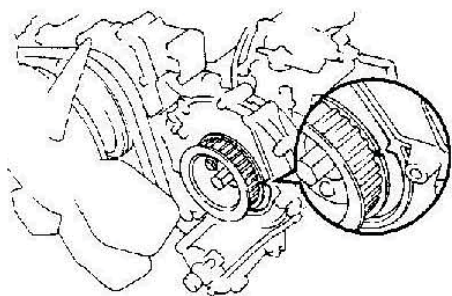

2. PUT CYLINDER No.4 IN TOP DEAD POSITION ON ITS COMPRESSION STROKE

Rotate the cylinder head pulley to the position of top dead center (TDC) mark of the timing casing cover in front of the cam No.2 shaft timing pulley.

3. REINSTALL THE CYLINDER HEAD

A. Install the cylinder head on the cylinder block.

- a. Install a new cylinder head gasket on the cylinder block and on its positioning studs.

REMARK:

Pay attention to the recommended assembly direction

- b. Reinstall the cylinder head on the new cylinder head gasket.

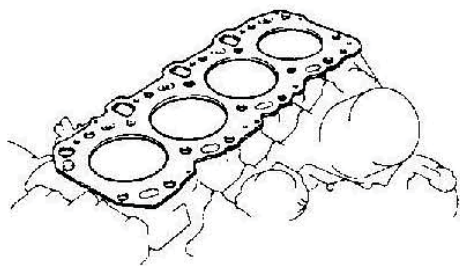

B. Reinstall cylinder head bolts.

ADVICE:

* Cylinder bolts must be tightened gradually in three stages (stages (b), (d) and (e)).

* Any broken or deformed cylinder head bolt must be replaced.

- a. Put a drop of engine oil on bolt threads and under bolt heads before reinstalling them.
- b. Reinstall and uniformly tighten these eighteen cylinder head bolts in several steps in compliance with the order indicated in the figure opposite.

**Recommended tightening torque:
39 N.m (400 kgf.cm)**

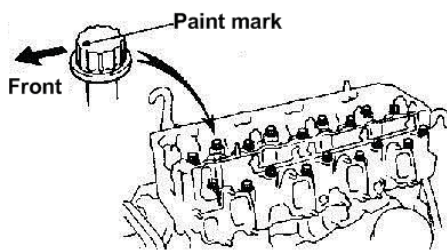
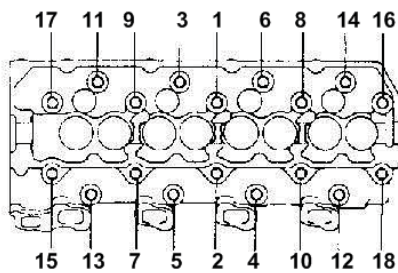
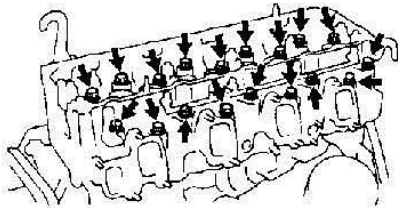

- c. Identify the front of the cylinder head bolt with paint.

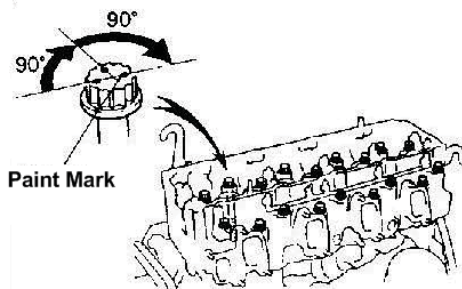

- d. Tighten cylinder head bolts 90° in the number order indicated in the illustration opposite.
- e. Tighten cylinder head bolts 90° more.
- f. Verify that the painted mark is now facing towards the rear.

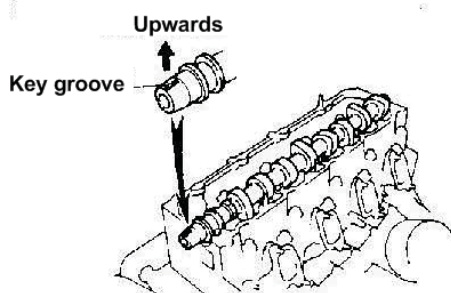

4. REINSTALL THE CAMSHAFT

- a. Install the cam shaft on the cylinder taking care to direct the key groove upwards

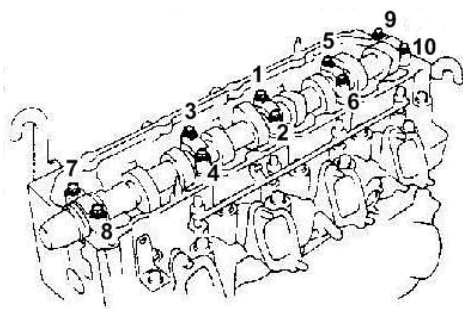
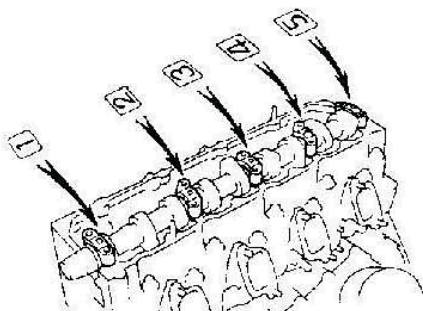

- b. reinstall the five bearing caps at their respective locations.
- c. Reinstall and evenly tighten the ten bearing cap bolts to the recommended torque, in the tightening order indicated opposite.

**Recommended tightening torque:
18 N.m (185 kgf.cm)**

5. REINSTALL THE CAMSHAFT OIL GASKET RETAINER

- a. Carefully remove all signs of former sealant (FIPG) from mating surfaces and take care not to dirty the assembly surfaces of the cylinder head and cam shaft oil gasket retainer with oil.

* Carefully remove all signs of former sealant (FIPG) from gasket application surfaces and from the sealing groove using a razor blade and scraper designed for this purpose.

* Carefully clean all removed parts to ensure that no signs of sealant remain.

* Clean the two sealing surfaces with a residue-free solvent

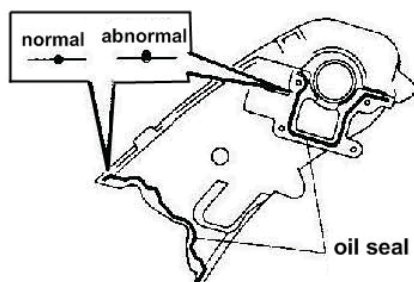

- b. Apply a bead of sealant to the timing casing cover as shown in the figure opposite.

* Install a nozzle on the tube already cut to make a 2 to 3 mm opening.

ADVICE:

Make sure not to apply an excessive quantity of the product on the assembly surface.

* Parts must be assembled within 5 minutes of the product being applied. Otherwise the sealant must be entirely removed and reapplied.

* Immediately remove the nozzle from the tube and tighten the closing cap.

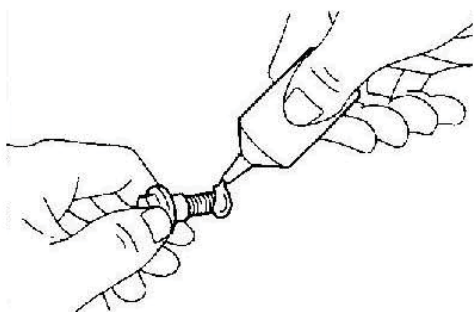

c. Coat two or three threads at the end of assembly bolts with sealant

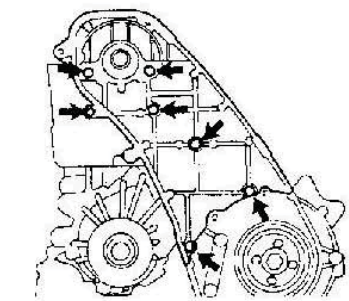

d. Reinstall the retainer using the seven assembly bolts.

**Recommended tightening torque:
9 N.m (90kgf.cm)**

6. REINSTALL THE TIMING BELT AND THE PULLEYS

7. VERIFY AND SET THE VALVE CLEARANCE

Rotate the cam shaft and put the cam tops up, then verify and adjust the valve clearance.

Valve clearance (cold):

Intake: 0.20 – 0.30 mm

Exhaust: 0.25 – 0.35 mm

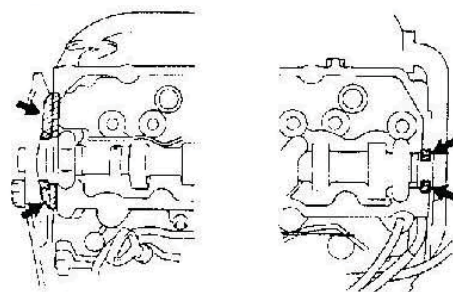

8. REINSTALL THE ROCKER COVER

- Remove any signs of former gasket on the joint
- Coat the cylinder head and the locations illustrated in the figure opposite with sealant.

**REFER TO THE MAINTENANCE MANUAL TO
ADJUST VALVES**

INJECTORS AND INJECTION PUMP

INJECTORS

COMPONENT PART (REMOVAL AND REINSTALLATION)

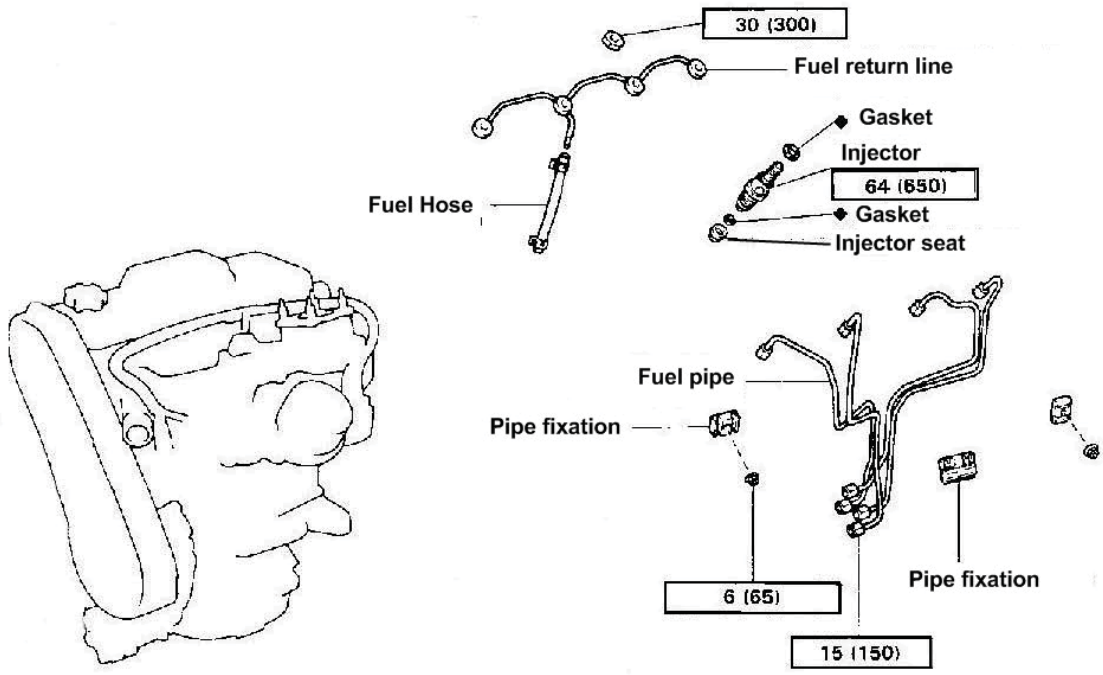

N.m (kgf.cm) : Specified tightening torque

◆ Non reusable part

REMOVE THE INJECTION PIPES

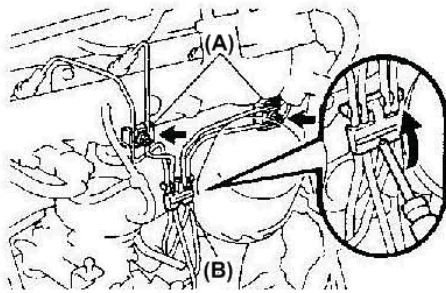

- a. Loosen the two nuts securing fasteners (A) on the intake manifold.
- b. Use a screwdriver to prise off the fastener (B).

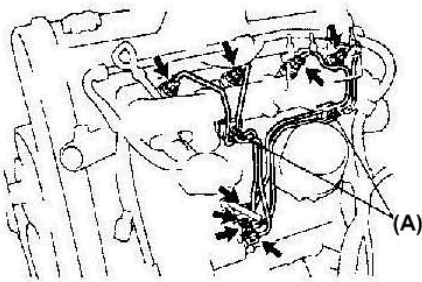

- c. Loosen the eight injection pipe attachment coupling nuts.
- d. Remove the four injection pipes and the two pipe retainers (A).

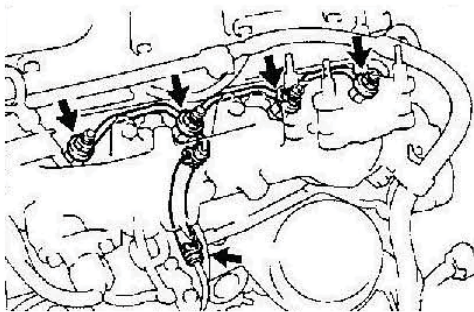

REMOVE THE FUEL RETURN PIPE

- a. Disconnect the flexible supply pipe from the fuel return pipe.
- b. Remove the four attachment nuts, the fuel drop pipe and the four seals.

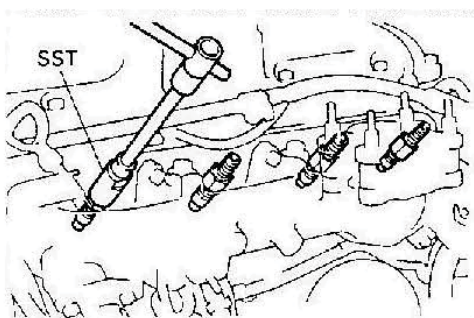

REMOVE THE INJECTORS

Remove the four injectors, the seats and the seals using special maintenance tool SST.

ADVICE: Remove the injectors in the logical order corresponding to the cylinders

INJECTOR TEST

INJECTION PRESSURE TEST

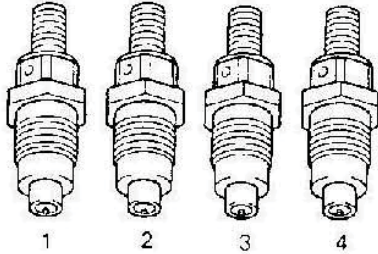

- a. Install the injector to check on an injector test bench and bleed out the air by the coupling nut

PRECAUTION:

Never put a finger in front of the injector injection hole.

- b. Operate the control lever quickly so as to cause injection several times and remove any possible accumulation of carbon deposits at the injector nozzle.
- c. Operate the control lever more slowly and observe the pressure indicated by the pressure gauge.
- d. Interpret the pressure indicated by the pressure gauge as soon as the injection pressure drops abruptly.

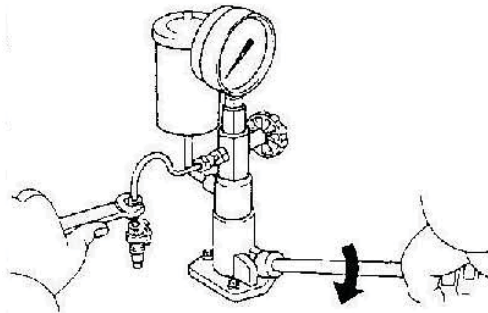

Opening pressure:

New injector:

14.808 – 15.593 kPa (151 – 159 kgf/cm²)

Reinstalled injector

14.710 – 15.593 kPa (150 – 159 kgf/cm²)

ADVICE:

Whistling indicates that the injector is operating normally.

If the injection pressure is not within the limits stipulated in specifications, remove the injector and replace the thickness shim located at the top part of the injection pressure adjustment spring.

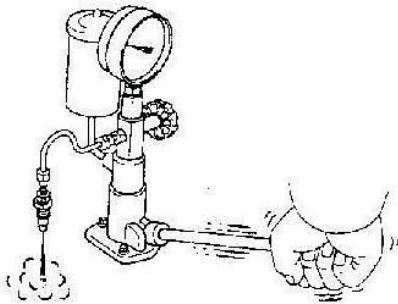

Adjusted injection pressure

14.710 – 15.593 kPa (150 – 159 kgf/cm²)

Thickness shim thickness		
0,900	1,275	1,650
0,925	1,300	1,675
0,950	1,325	1,700
0,975	1,350	1,725
1,000	1,375	1,750
1,025	1,400	1,775
1,050	1,425	1,800
1,075	1,450	1,825
1,100	1,475	1,850
1,125	1,500	1,875
1,150	1,525	1,900
1,175	1,550	1,925
1,200	1,575	1,950
1,225	1,600	
1,250	1,625	

ADVICE:

* Modifying the thickness of the thickness shim by 0.025 mm makes the injection pressure change by approx. 471 kPa (4.8 kgf/cm²).

* Only one thickness shim should be used.

e. Verify that no fuel drops are found during post-detection

DROP TEST

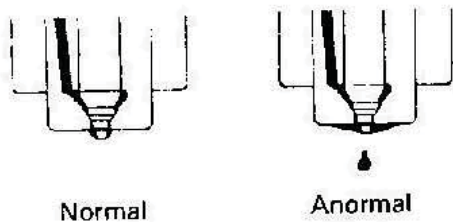

Hold the pressure at approx. 981 – 1,961 kPa (10 – 20 kgf/cm²) under the opening pressure, which is adjusted with the controller lever, and verify that no fuel drops occur for 10 seconds by the injector nozzle or around the attachment nut.

If a fuel drop is found in less than 10 seconds, replace or disassemble the injector to clean it and generally overhaul.

FUEL ATOMIZATION CONDITION TEST

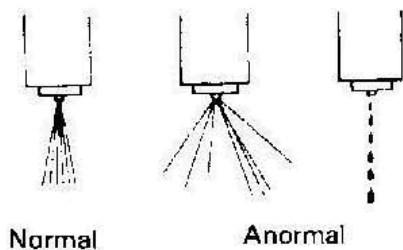

- The injector undergoing the test must shake when the controller lever is operated at a rate of 15 to 60 times (reinstalled injector) or 30 to 60 times (new injector) per minute.
- Verify the shape of the fuel atomization jet when the injector shakes.
-

If the shape of the fuel atomization jet is not satisfactory, replace or clean the injector.

COMPONENT PART DISASSEMBLY AND REASSEMBLY

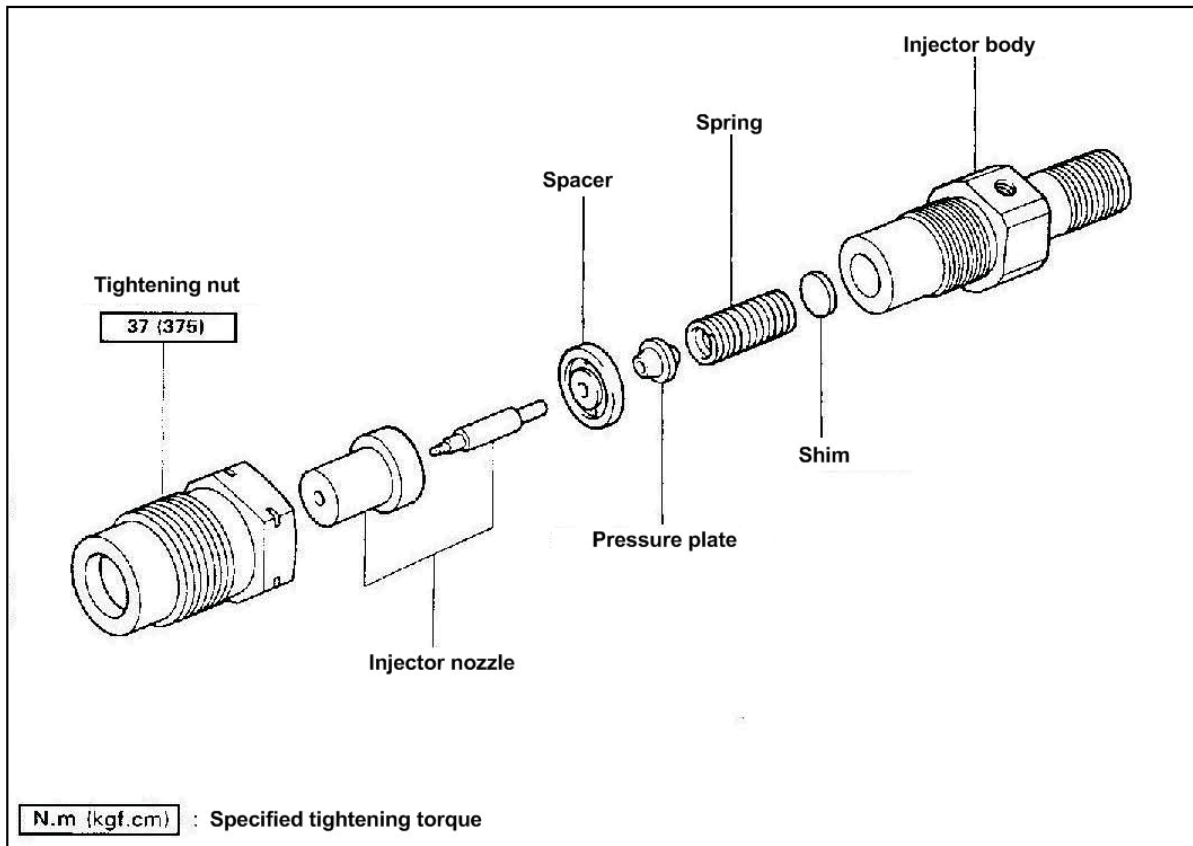

DISASSEMBLING THE INJECTORS

DISASSEMBLE THE INJECTORS

- a. Use special maintenance tool SST to loosen the injector carrier attachment nut.

REMARK: When disassembling the injector, make sure not to let any internal parts fall.

- b. Remove the pressure spring, the thickness shim, the pressure pin, the spacing part and the injector.

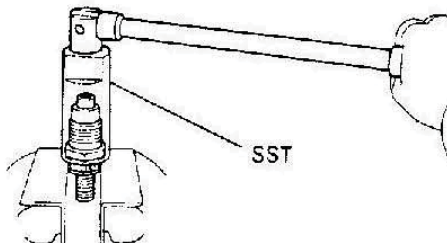

CLEANING AND CHECKING INJECTORS

CLEANING THE INJECTOR

- a. Use a thin bar and a brass rod to clean the injectors. Also clean using fresh diesel fuel.



ADVICE:

Never touch assembly surfaces of the injector with your fingers.

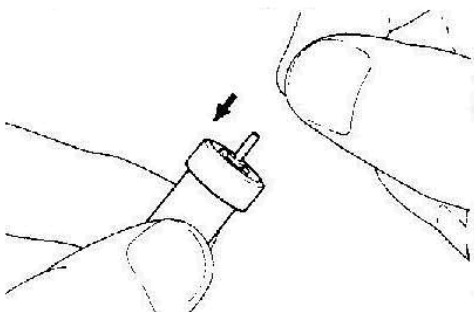
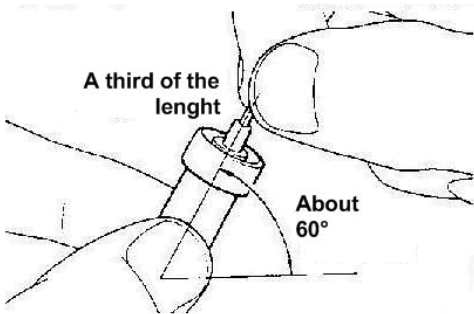
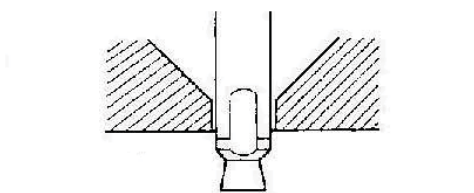
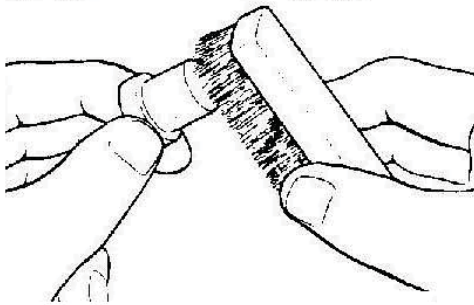
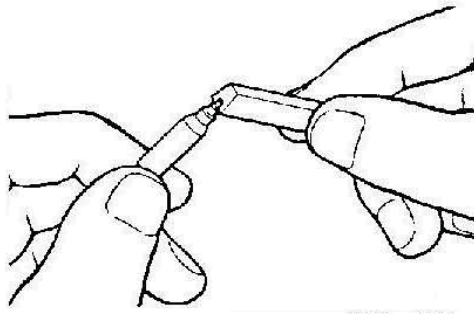

b. remove the carbon deposits accumulated at the end of the injector needle valve with the bar

c. Use a brass bristle brush to remove the carbon deposits from the external parts of the injector nozzle (without touching the lapped surface).

d. Verify the degree of corrosion or burning on the injector body.

e. Check whether the injector needle valve is damaged and corroded. Replace complete injector when any one of the parts has the slightest defect.

CHECK THE INJECTORS

a. Carefully clean the injector in fresh diesel fuel.

ADVICE:

Never touch the assembly surfaces of the injector with your fingers.

b. Incline the body of the injector approximately 60° and pull out the injector needle valve approximately one third.

c. Release the injector needle valve and check that it falls back normally in the injector body under its own weight.

d. Repeat this test turning the injector needle valve a little each time. If the injector needle valve does not fall back into a given position, replace the complete injector

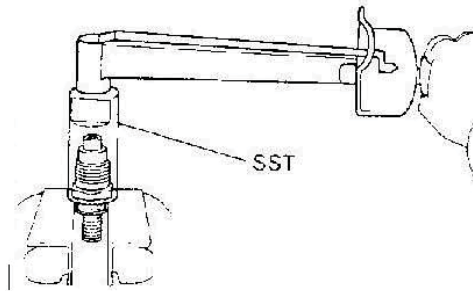

REASSEMBLING THE INJECTORS

(Refer to the component part illustration for disassembly and reassembly operations)

REINSTALL THE INJECTOR

- Reinstall the injector carrier attachment nut, the complete injector, the spacing part, the pressure pin, the pressure spring, the thickness adjustment shim and the injector carrier body. The attachment nut is to be tightened by hand.
- Use special maintenance tool SST to tighten the attachment nut to the recommended tightening torque.

Recommended tightening torque: 37 N.m (375 kgf.cm)

REMARK:

Excessive tightening may cause deformation of the injector or sticking of the injector needle valve or another fault. CARRY OUT AN INJECTION PRESSURE TEST AND FUEL ATOMIZATION JET SHAPE TEST.

REINSTALL THE INJECTORS

(refer to the component part illustration for removal and reinstallation)

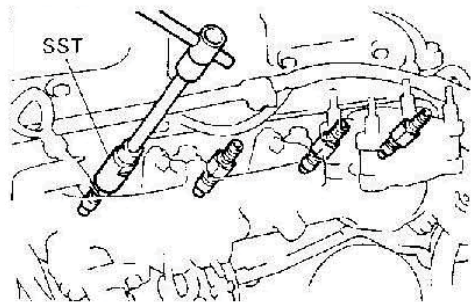

REINSTALLING THE INJECTORS

- Reinstall the four injector cups with new rings in the cylinder head injector holes.
- Use special maintenance tool SST to reinstall and tighten the injectors to the recommended tightening torque.

Recommended tightening torque: 64 N.m (650 kgf.cm)

REMARK:

* Excessive tightening may cause deformation of the injector or sticking of the injector needle valve or another fault.
* When reinstalling an injector, never tighten the injector body. Only tighten the section of the retaining nut.

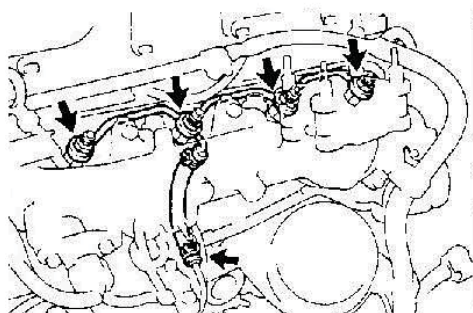

REINSTALL THE INJECTOR FUEL RETURN PIPE

- Reinstall four new rings and the fuel drop pipe with the attachment nuts.

Recommended tightening torque: 30 N.m (300 kgf.cm)

- Reconnect the flexible supply pipe to the fuel return pipe.

REINSTALL THE INJECTOR PIPES

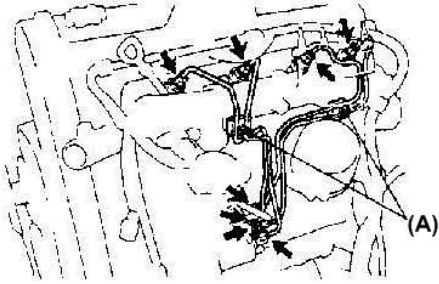

- a. Temporarily reinstall the four injection pipes and the two fasteners (A)

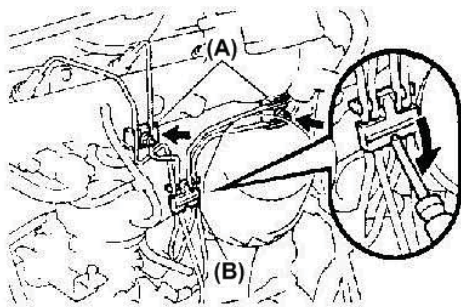

- b. Reinstall the two attachment nuts securing the fasteners (A) to the intake manifold.

**Recommended tightening torque:
6 N.m (65 kgf.cm)**

- c. Use a screwdriver to secure the fastener (B).
- d. Tighten the eight coupling nuts to the recommended tightening torque.

**Recommended tightening torque:
15 N.m (150 kgf.cm)**

**START THE ENGINE AND CHECK WHETHER THERE ARE ANY
LEAKS**

INJECTION PUMP

Component part (disassembling and reassembling)

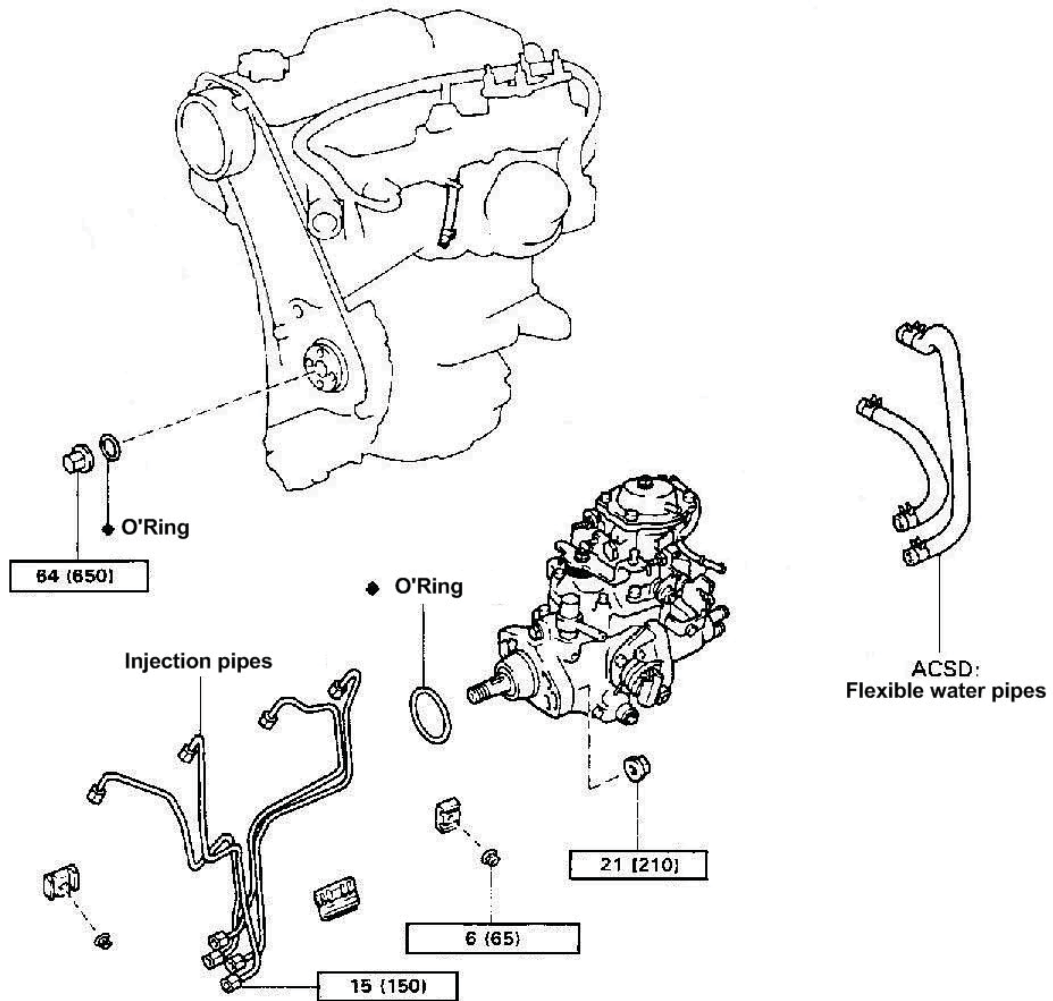

N.m (kgf.cm) : Specified tightening torque

◆ Non reusable part

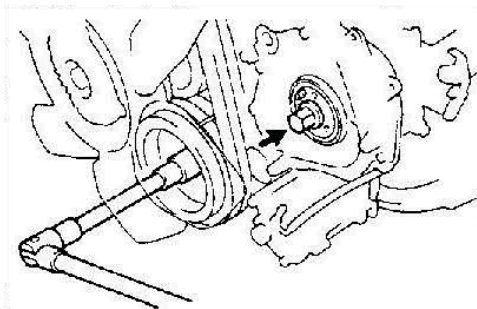

- a) Immobilize the crankshaft pulley and remove the injection pump drive pinion attachment nut

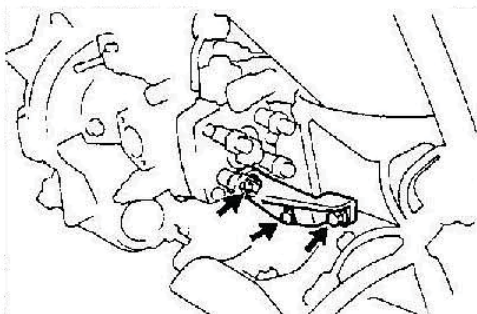

- b) Remove the three assembly bolts and the injection pump spacer.

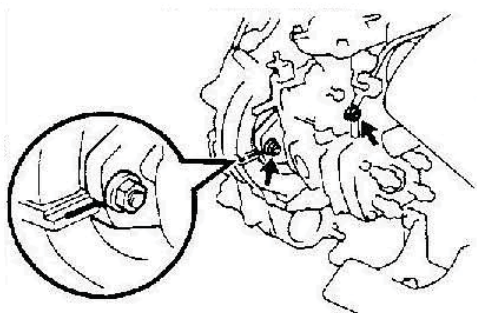

- c) Before removing the injection pump, check whether the timing lines are aligned.

If this is not the case, make new alignment marks on the injection pump to facilitate reassembly. Remove the two attachment nuts securing the injection pump to the timing gear casing

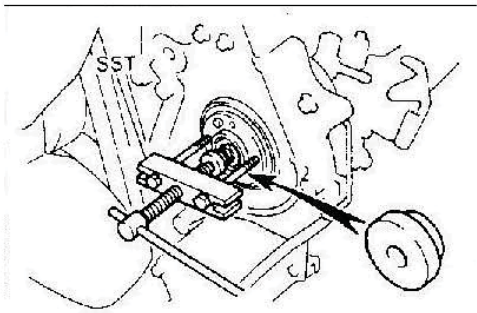

- d) Use the special maintenance tool SST to remove the injection pump.

REMARK:

- * Screw the two assembly bolts in over more than 8 mm.
- * Install the special maintenance tool SST so that it is properly balanced.
- * Do not grip or transport the injection pump using the adjustment lever.
- * Do not incline the injection pump at an angle greater than 45° in relation to the horizontal.

- e) Remove the injection pump o-ring.

REFER TO THE MAINTENANCE MANUAL TO SET THE INJECTION PUMP TIMING

FRESH WATER PUMP and WATER SENSOR

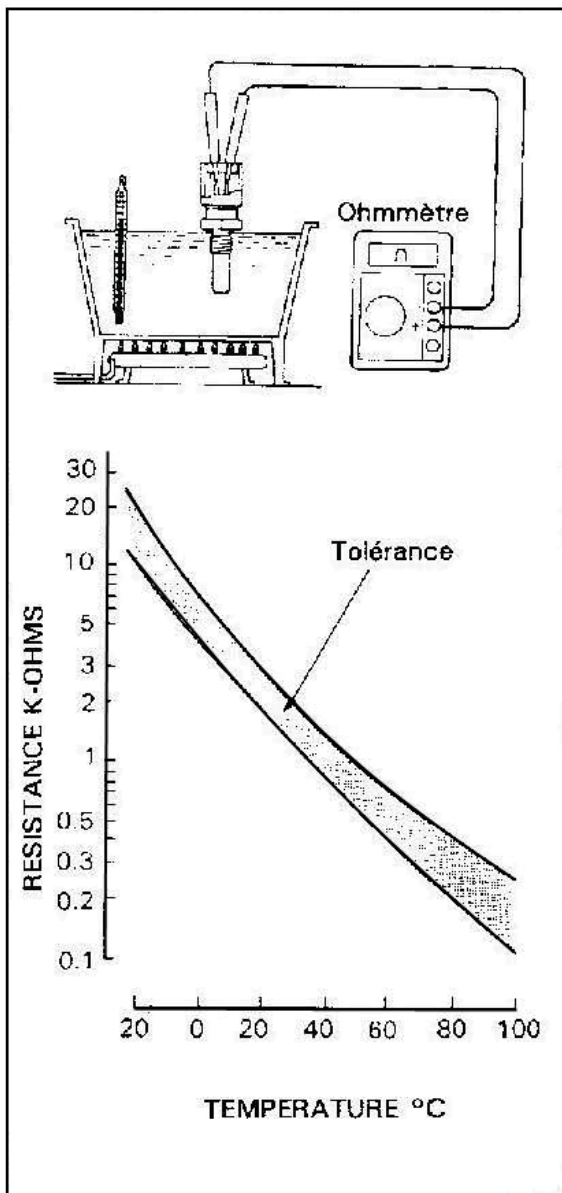

CHECKING THE WATER TEMPERATURE SENSOR

1. REMOVE THE WATER TEMPERATURE SENSOR
2. VERIFY THE WATER TEMPERATURE SENSOR

Use the special maintenance tool SST to verify the resistance between the terminals using an ohmmeter.

Resistance: (Refer to the diagram)

If the resistance is not within the limits stipulated in specifications, replace the water temperature sensor

3. REINSTALL THE WATER TEMPERATURE SENSOR

FRESH WATER PUMP

Component part (removal and reassembly)

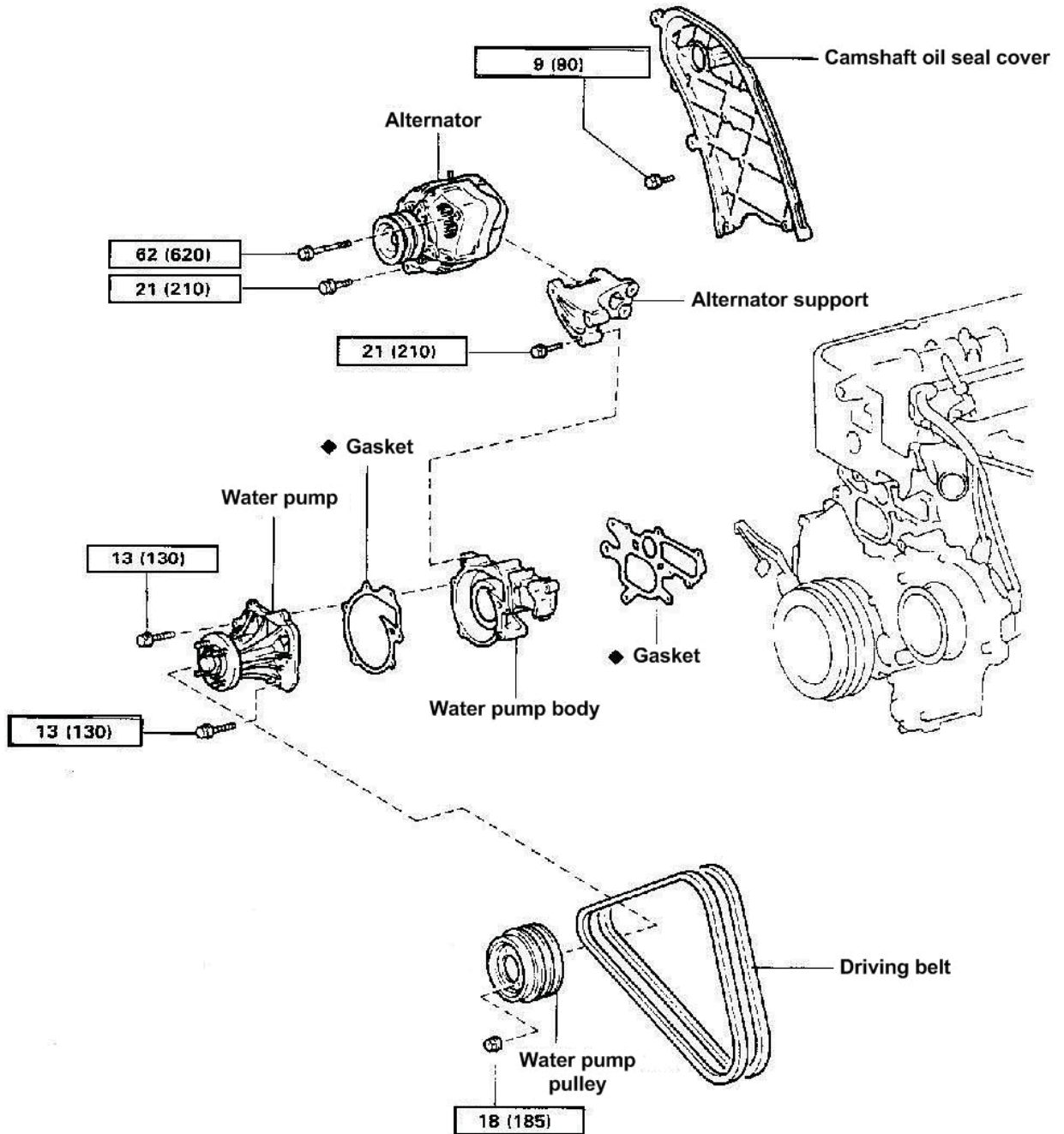

N.m (kgf.cm) : Specified tightening torque

◆ Non reusable part

REMOVING THE WATER PUMP (Refer to component part illustration for disassembly and reassembly)

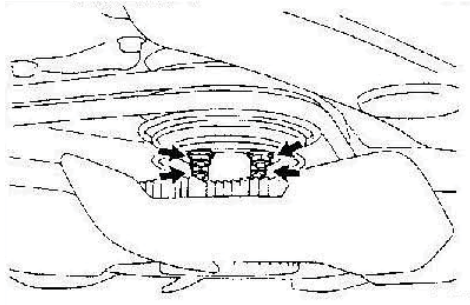

1. DRAIN THE ENGINE COOLANT
2. REMOVE THE DRIVE BELT AND THE WATER PUMP PULLEY
 - a. Pull the drive belt as much as possible and loosen the four water pump pulley attachment nuts.
 - b. Loosen the pivot bolt and the adjustment lock bolt.
 - c. Loosen the adjustment bolt and remove the drive belt.
 - d. Remove all four attachment nuts, the fan and the hydraulic coupling, and also the water pump drive pulley.

3. REMOVE THE TIMING BELT AND THE INTERMEDIATE PULLEY

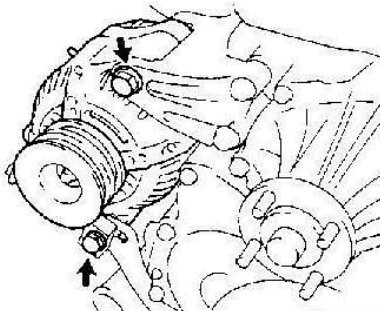

4. REMOVE THE CAMSHAFT TIMING PULLEY
5. REMOVE THE CAMSHAFT OIL SEAL RETAINER
6. REMOVE THE WATER PUMP

- a. Remove the lock bolt and the pivot bolt, as well as the alternator.

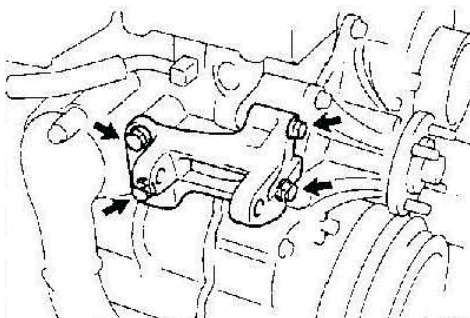

- b. Remove the four assembly bolts and the alternator attachment plate.

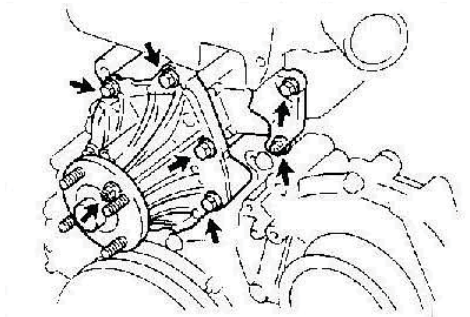

- c. Remove the five assembly bolts, two attachment nuts, the water pump and the gasket

- d. Remove the assembly bolt, the water pump cover and the gasket.

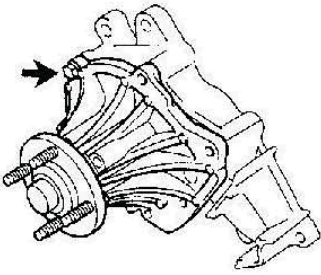

REASSEMBLING THE WATER PUMP

(Refer to component part illustration for removal and reinstallation)

1. REINSTALL THE COMPLETE WATER PUMP

- a. Install a new gasket on the water pump cover.
- b. Temporarily reinstall the water pump and the water pump cover with the assembly bolts

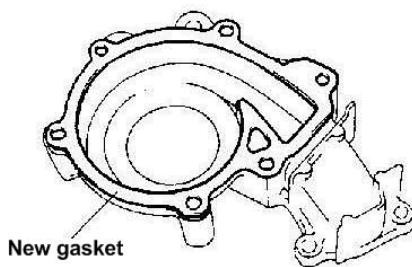

- c. Install a new gasket on the cylinder head.

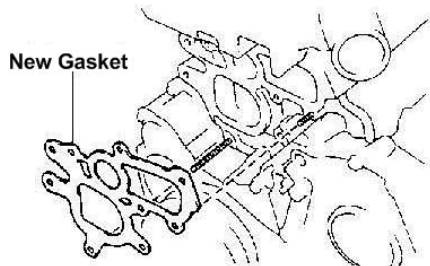
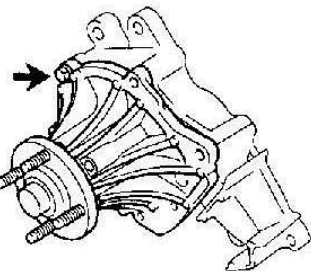

- d. Temporarily reinstall the water pump with the five assembly bolts and two attachment nuts.
- e. Tighten the assembly bolts and attachment nuts.

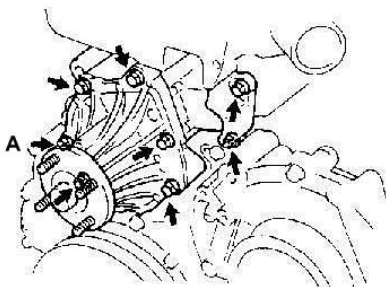

**Recommended tightening torque:
13 N.m (130kgf.cm)**

f. Reinstall the alternator with the pivot bolt and the lock bolt.

**Recommended tightening torque:
21 N.m (210 kgf.cm) for the lock bolt**

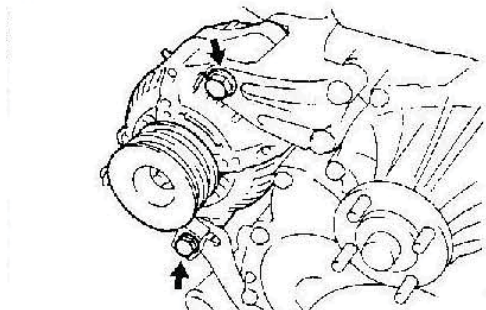

**Recommended tightening torque:
62 N.m (620 kgf.cm) for the pivot bolt**

2. REINSTALL THE CAM SHAFT OIL SEAL RETAINER
3. REINSTALL THE CAM SHAFT TIMING PULLEY
4. REINSTALL THE INTERMEDIATE PULLEY AND THE TIMING BELT
5. REINSTALL THE WATER PUMP PULLEY AND THE DRIVE BELT

- a. Reinstall the water pump drive pulley with the four assembly bolts.
- b. Install the drive belt on each of the water pump pulleys.
- c. Pull the drive belt as far as possible and tighten the four water pump pulley attachment nuts at the recommended tightening torque.

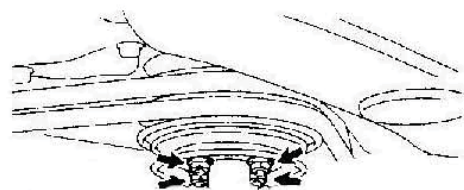

**Recommended tightening torque:
18 N.m (185 kgf.cm)**

- d. Adjust the drive belt sag.

6. FILL THE ENGINE WITH COOLANT
7. START THE ENGINE AND VERIFY WHETHER COOLANT LEAKS OCCUR

**REFER TO THE MAINTENANCE MANUAL FOR
COOLING CIRCUIT BLEEDING**

THERMOSTAT

Component part (removal and reinstallation)

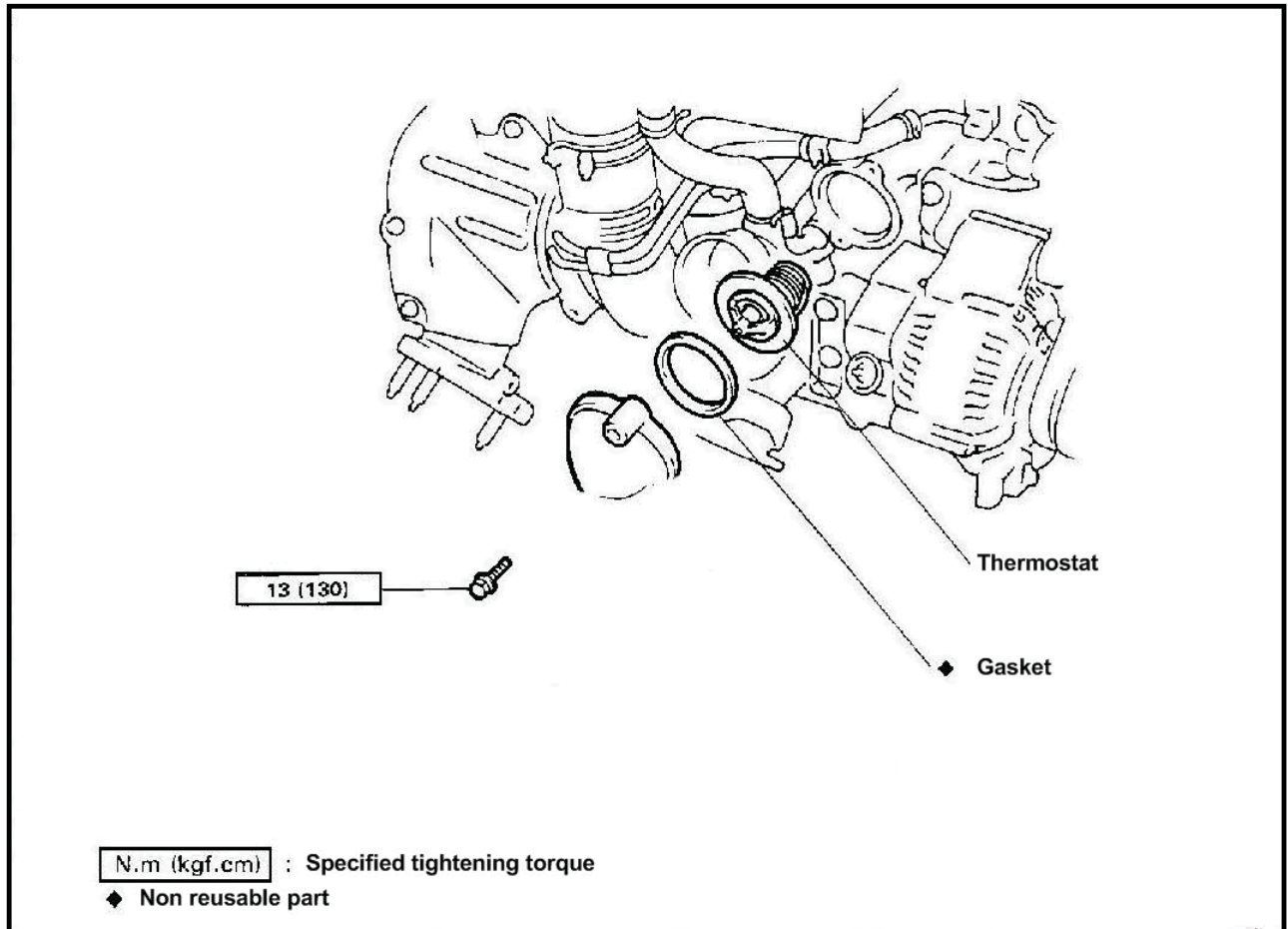

REMOVING THE THERMOSTAT

(Refer to component part illustration for removal and reinstallation)

ADVICE:

Simply removing the thermostat may have a negative effect and cause a decrease to cooling system efficiency. Do not remove the thermostat, even if the engine has a tendency to overheat.

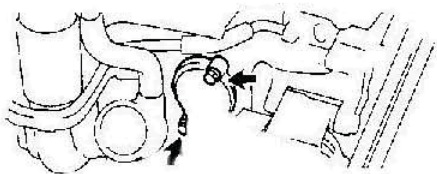

1. DRAIN THE ENGINE COOLANT
2. DISCONNECT THE WATER FEED HOSE AND REMOVE THE THERMOSTAT
 - a. Remove the assembly bolts and the cylinder block water feed pipe.
 - b. Remove the thermostat.
 - c. Remove the thermostat gasket

CHECKING THE THERMOSTAT

CHECK THE THERMOSTAT

ADVICE:

The thermostat is marked with a number according to the valve opening temperature.

- a. Dip the thermostat into water and heat the water gradually.
- b. Verify the valve opening temperature.

Valve opening temperature: 71°C

Replace the thermostat when the valve opening temperature is not within the limits complying with specifications.

- c. Verify the valve lift.

Valve lift: 8 mm or more at 85°C

Replace the thermostat when the valve lift is not within the limits complying with specifications.

- d. Check that the thermostat spring is fully stretched when the thermostat is fully closed.

Replace the thermostat if not fully closed

REINSTALLING THE THERMOSTAT

(refer to component part illustration for removal and reinstallation)



**Stud
valve**

1. REINSTALL THE THERMOSTAT ON THE CYLINDER BLOCK
 - a. reinstall a new gasket on the thermostat.
 - b. Reinstall the thermostat, taking care to direct the valve stud of the thermostat upwards.

2. REINSTALL THE WATER FEED PIPE ON THE CYLINDER BLOC

Reinstall the water feeder pipe.

**Recommended tightening torque:
13 N.m (130 kgf.cm)**

3. FILL THE ENGINE WITH COOLANT

4. START THE ENGINE AND VERIFY WHETHER COOLANT LEAKS OCCUR



PRE-HEATING

GLOW PLUGS COMPONENT PART (REMOVAL AND REINSTALLATION)

REMARK:

* Cylinder head seizing and opening of glow plugs may occur if carbon deposits accumulate. Also, twisting the glow plugs excessively when removing them may cause the ceramic to split. Consequently, wherever possible avoid moving glow plugs.

* The heating element is made of ceramic. Consequently, allowing the glow plug to fall or hitting it against a hard surface, even if this only occurs once, makes it necessary to replace it. Replace this glow plug whether new or re-used, whether the resistance is normal or not, even when there are no external signs of damage.

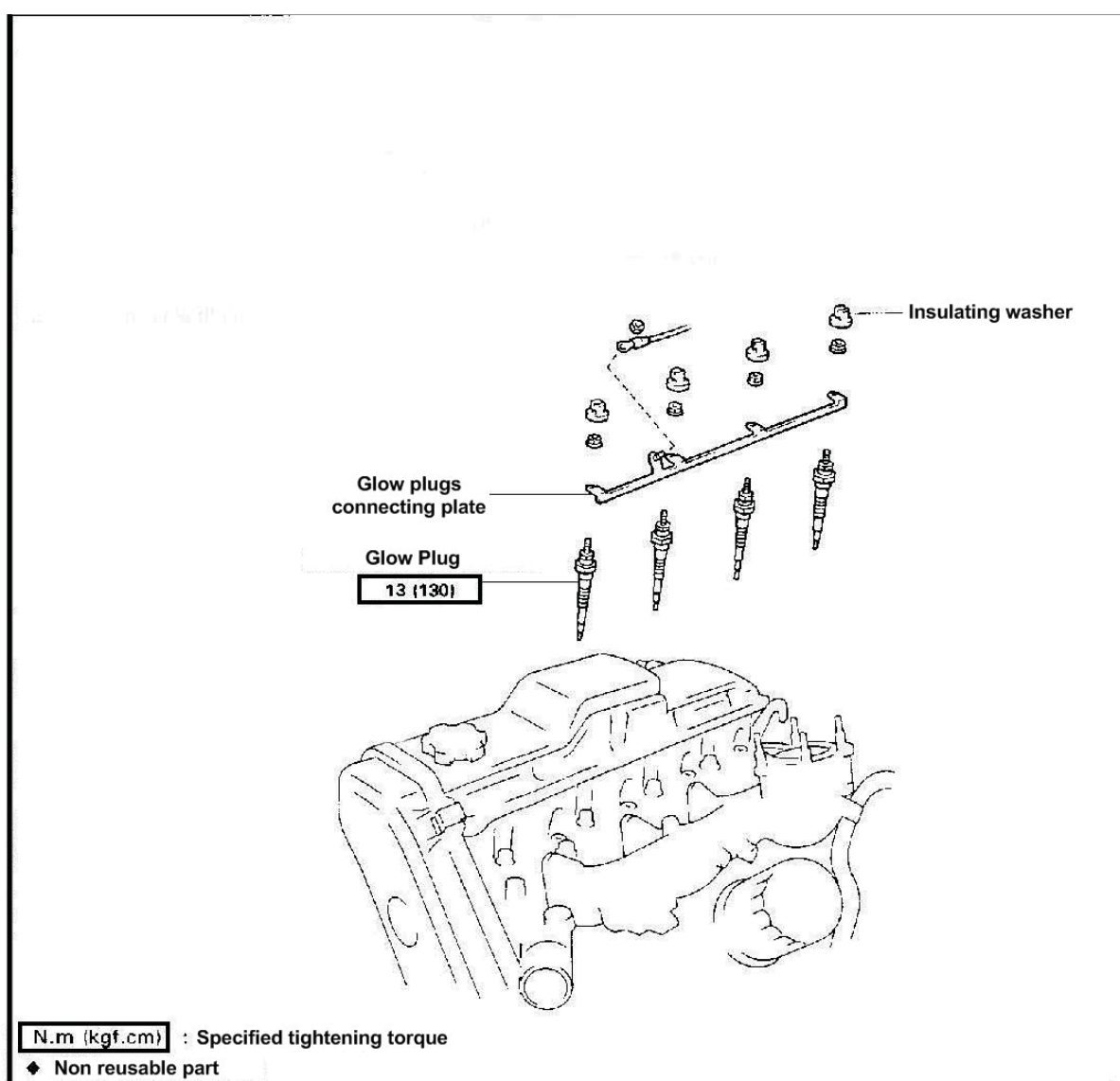

REMOVE THE GLOW PLUGS

- a. Remove the four screw insulating washers.
- b. Remove the four attachment nuts and the connection plate of the glow plugs

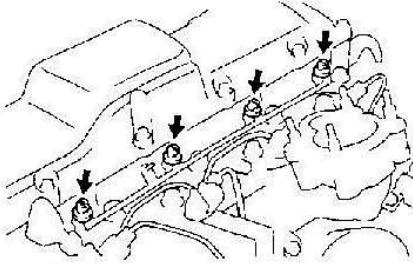

- c. Use a box spanner, depth 12 mm, to remove the four glow plugs.

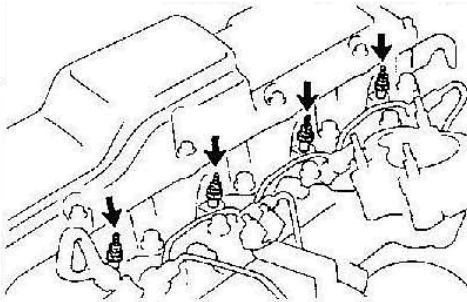

REINSTALLING THE GLOW PLUGS

(refer to component part illustration for removal and reinstallation)

REMARK:

before reinstalling the glow plugs, first remove any accumulation of carbon deposit on the glow plug holes in compliance with the procedure described below.

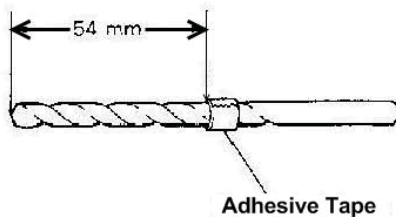

- a. Put a piece of 54 mm wide adhesive tape around a 6 mm drill.

6mm Drill

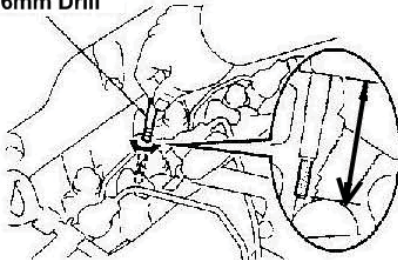

- b. Insert the 6 mm section of the drill with the adhesive tape in the glow plug hole and turn the drill to eliminate the carbon deposit.

4mm drill

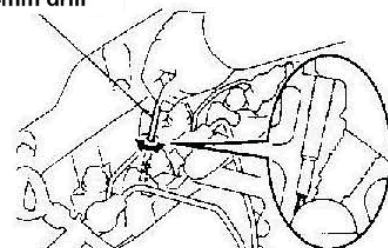

- c. Insert a 4 mm drill in the glow plug hole and turn the drill by hand to eliminate the carbon deposit on the edge of the hole.

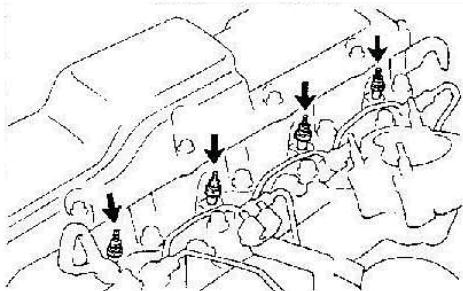

d. Use a 12 mm deep box spanner to reinstall the four glow plugs.

**Recommended tightening torque:
13 N.m (130 kgf.cm)**

CHECKING ON BOARD

REMARK:

When checking the glow plug resistance, the engine must on board. Avoid removing and reinstalling glow plugs as far as possible.

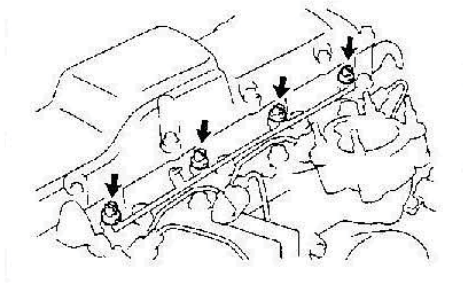

CHECKING GLOW PLUGS

Check that there is electrical continuity between the glow plug terminal and the earth with an ohmmeter.

Resistance (measured cold): Approx 0.65Ω

Replace any glow plug with a resistance level greater than 1.0Ω.

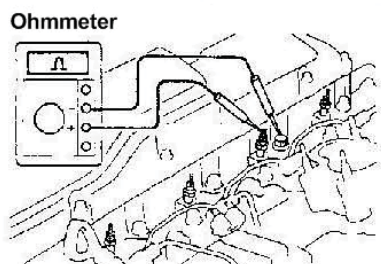

OIL PRESSURE, OIL INJECTORS, OIL PUMP, OIL COOLER

CHECKING THE OIL PRESSURE

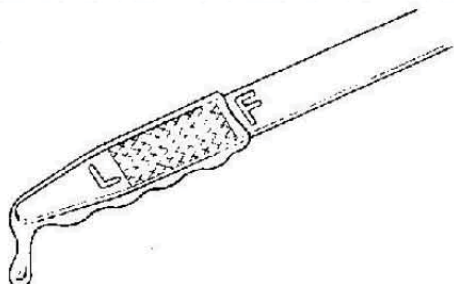

1. CHECK THE ENGINE OIL QUALITY

Check the level of quality of the oil, infiltration of water in the oil, its colour and its lubrication capacity.

Drain the engine oil if the quality is bad.

Oil quality: API CD oil quality or greater.

Appropriate viscosity index: 15 W 40

2. CHECK THE ENGINE OIL LEVEL

The engine oil level must be between the marks "L" and "F" on the oil level gauge.

Check whether there are any leaks and top up so that the oil level is at the "F" mark.

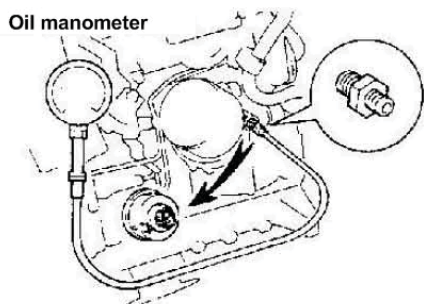

3. REMOVE THE OIL SENDER GAUGE

4. INSTALLING OIL PRESSURE GAUGE IN ITS PLACE

5. WARM UP THE ENGINE

Start the engine and allow it to heat until it reaches its normal operating temperature.

6. MEASURE THE OIL PRESSURE

Oil pressure:

At idle speed: Equal to or greater than 29 kPa (0.3 kgf/cm²)

At engine speed greater than 3000 rpm: 250 – 600 kPa (2.5 – 6.1 kgf/cm²)

7. REMOVE THE OIL PRESSURE GAUGE

8. REINSTALL THE OIL LEVEL SENDER GAUGE

- a. Coat two or three threads with adhesive on the threaded section of the oil level sender gauge.

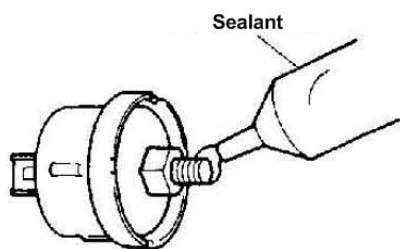

Adhesive product:

LOCTITE 242 or equivalent product

- b. Reinstall the oil level sender gauge.

9. START THE ENGINE AND VERIFY THAT THERE ARE NO OIL LEAKS

OIL JET component part (removal and reinstalling)

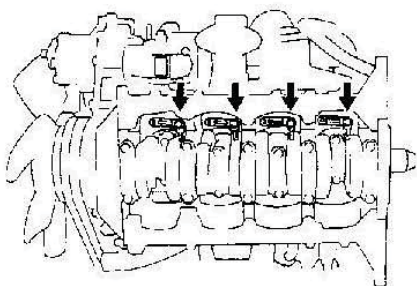
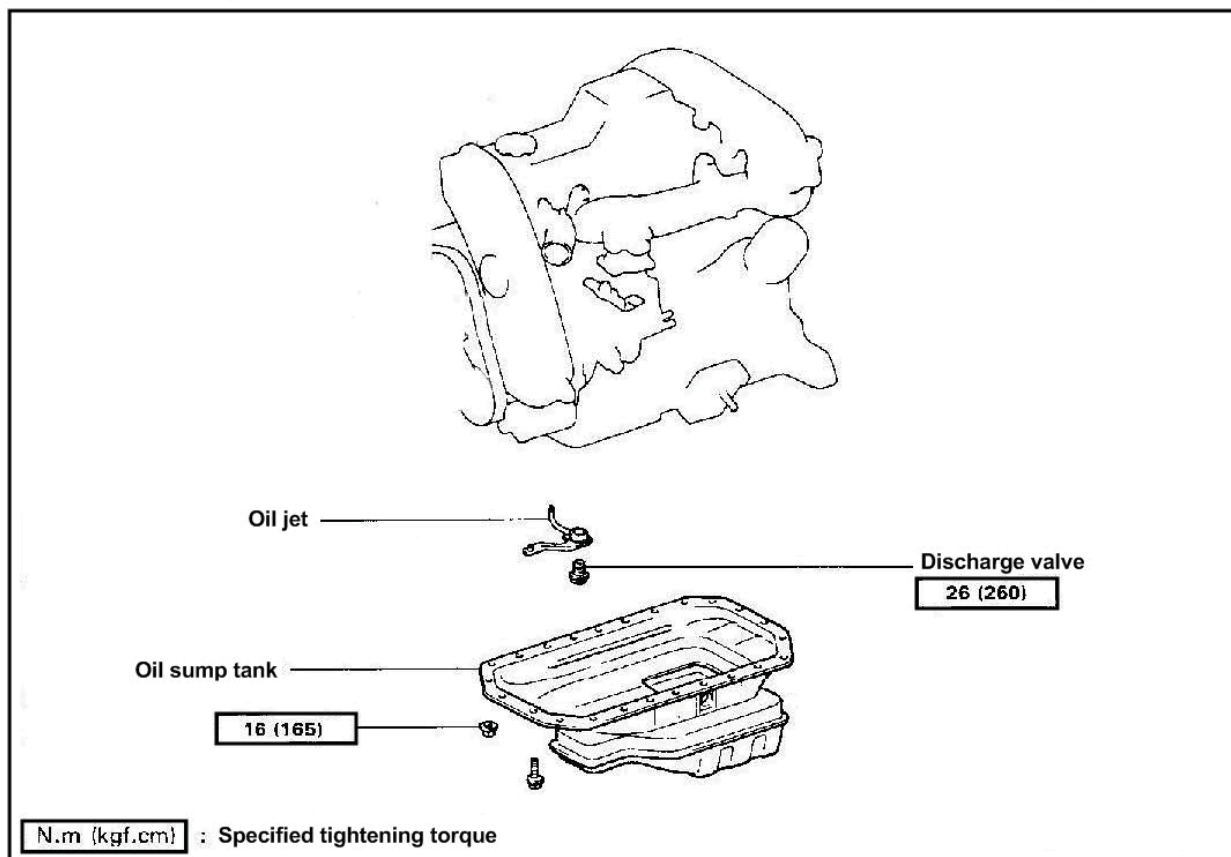

REMOVE OIL JETS

1. DRAIN THE ENGINE OIL
2. REMOVE THE ENGINE BOTTOM CASING
3. REMOVE THE CHECK VALVE AND THE OIL JETS

Remove the four check valves and the oil jets.

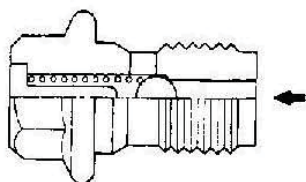

CHECKING OIL JETS

1. CHECK THE CHECK VALVES

Press the check valve with a piece of hard wood and verify whether it sticks. If it sticks, replace it.

2. CHECK OIL JETS

Check the degree of damage or clogging of oil jets. If necessary, replace it.

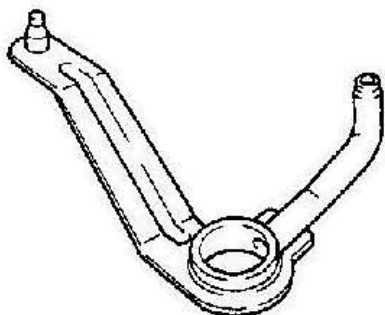

REINSTALLING OIL JETS

(Refer to component part illustration for removal and reinstallation)

1. REINSTALL OIL JETS AND THE CHECK VALVES
 - a. Make the lubrication injector pin coincide with the corresponding hole in the cylinder block.
 - b. Reinstall the lubrication injector with the check valve. Reinstall the four oil jets and the check valve.

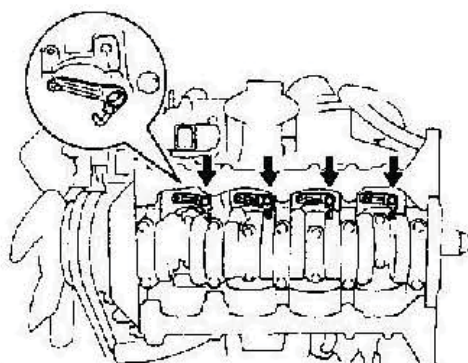

Recommended tightening torque:
26 N.m (260 kgf.cm)

2. REINSTALL THE ENGINE BOTTOM CASING.
3. FILL WITH ENGINE OIL.
4. START THE ENGINE AND VERIFY THAT THERE ARE NO LEAKS.

OIL PUMP

Component parts (removal and reinstallation)

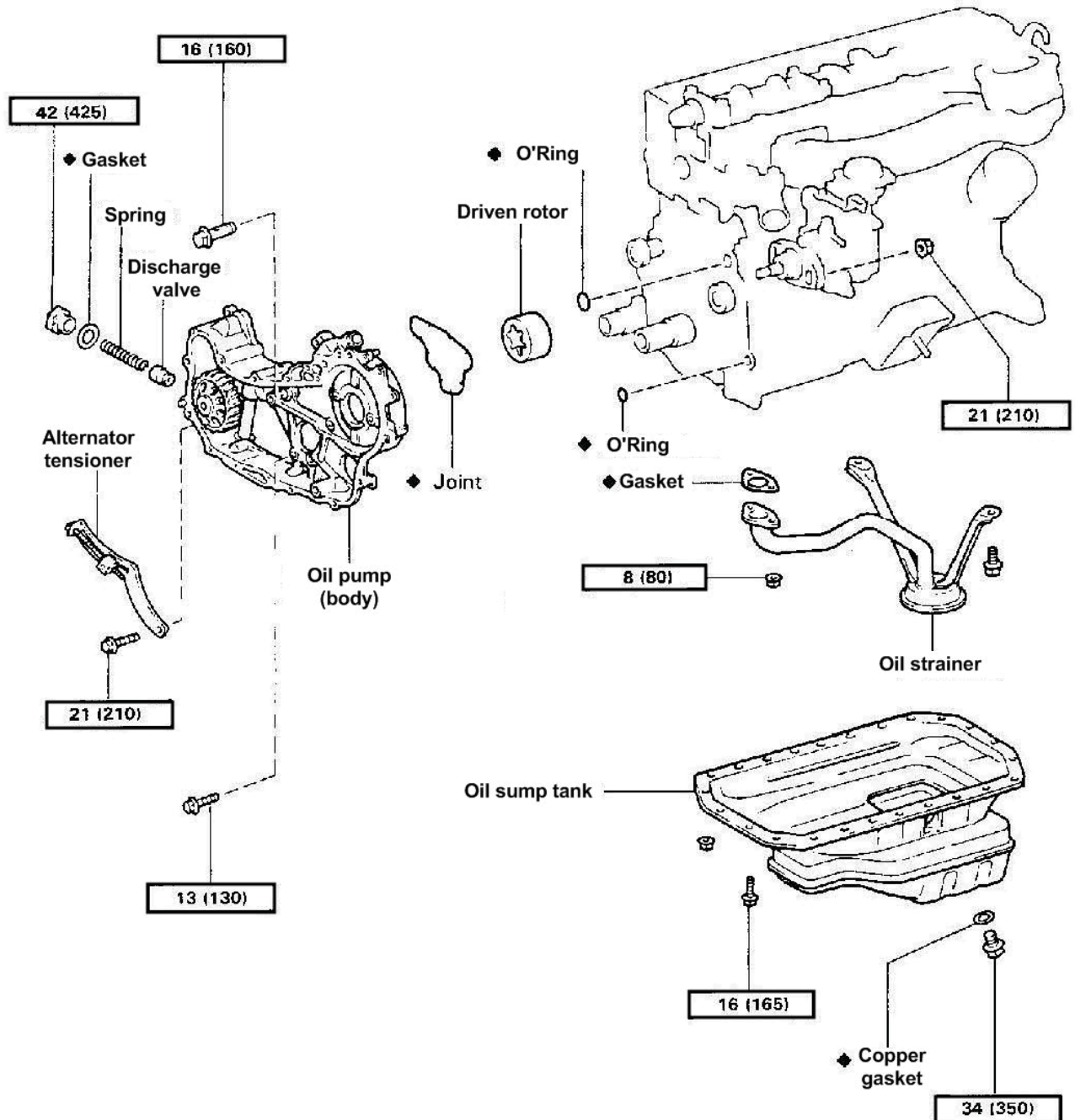

N.m (kgf.cm) : Specified tightening torque

◆ Non reusable part

REMOVING THE OIL PUMP

(Refer to component part illustration for removal and reinstallation)

ADVICE:

When repairing the oil pump, carefully clean the engine bottom casing and remove the oil strainer to clean it.

1. DRAIN THE ENGINE COOLANT
2. DRAIN THE ENGINE OIL
3. REMOVE THE DRIVE BELT AND THE WATER PUMP PULLEY
4. REMOVE THE TIMING BELT
5. REMOVE THE TIMING GEARS
6. REMOVE THE ALTERNATOR ADJUSTMENT BAR
 - a) Remove the lock bolt.
 - b) Remove the assembly bolt and the adjustment bar.
7. REMOVE THE ALTERNATOR AND THE ALTERNATOR ATTACHMENT PLATE.
8. REMOVE THE WATER PUMP
9. REMOVE THE ENGINE BOTTOM CASING
 - a) Remove the twenty-two assembly bolts and the two attachment nuts.

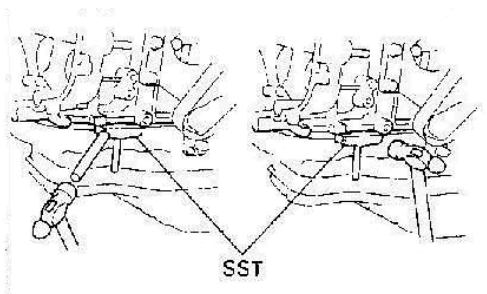
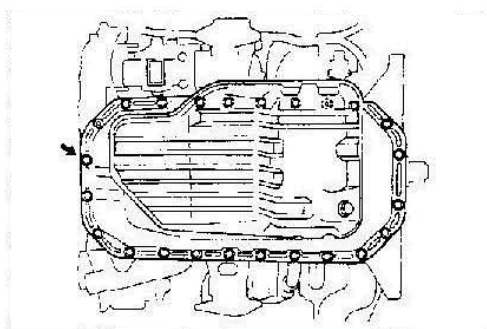
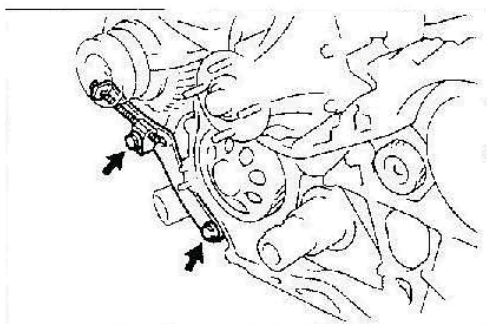

- b) Insert the blade of special maintenance tool SST between the engine bottom casing and the cylinder block to cut the sealant and remove the engine bottom casing.

REMARK:

* Do not use special maintenance tool SST for the rear

10. REMOVE THE OIL STRAINER

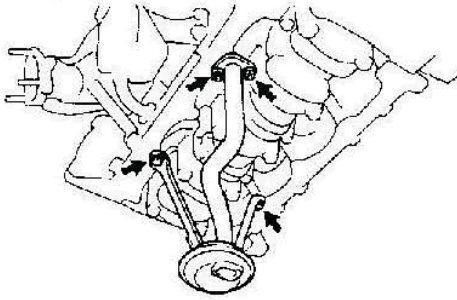

Remove the two attachment bolts, two nuts and the oil strainer and gasket

11. REMOVE THE OIL PUMP TIMING CASING

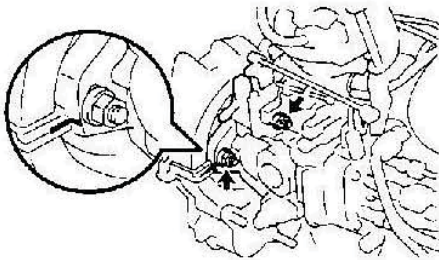

Before removing the two nuts securing the injection pump flange on the timing casing, verify that the timing lines coincide correctly. Otherwise mark alignment marks to facilitate reassembly. Remove the two attachment nuts

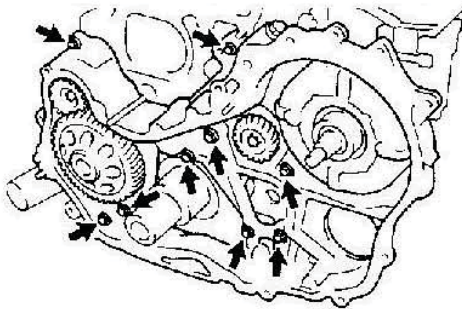

Remove the eight assembly bolts and the coupling bolt.

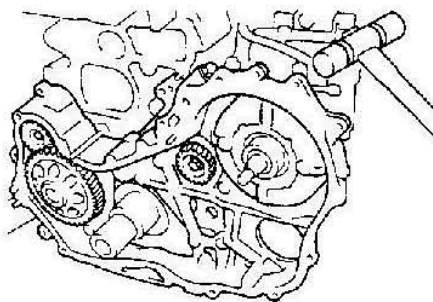

Use a plastic mallet to softly strike the distribution casing. Remove the three o-rings

DISASSEMBLING THE OIL PUMP

(Refer to component part illustration for removal and reinstallation)

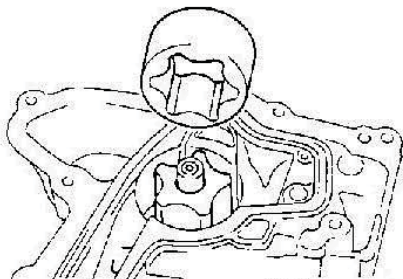

1. REMOVE THE DRIVEN ROTOR.
2. REMOVE THE DISCHARGE VALVE.

Remove the threaded cap, the gasket, the spring and the discharge valve.

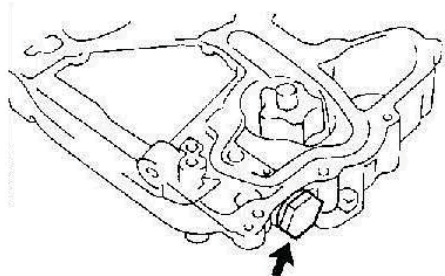

CHECKING THE OIL PUMP

1. CHECK THE DISCHARGE VALVE.

Put engine oil on the discharge valve and verify that it falls normally under its own weight in the bore.

Replace the discharge valve otherwise. If necessary, replace the complete oil pump.

2. CHECK THE DRIVING AND DRIVEN ROTORS

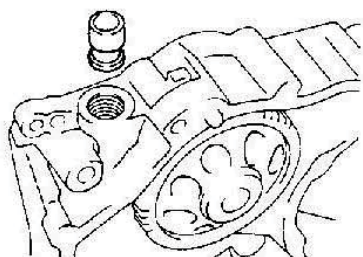

A. Check the rotor clearance

Measure the clearance between the driven rotor and the oil pump body using a set of thickness shims.

Nominal clearance of the rotor type oil pump body:

0.100 – 0.170 mm

Clearance limit of the rotor type oil pump body:

0.20 mm

Replace the rotors if the recorded clearance is greater than the indicated limit. If necessary, replace the complete oil pump.

B. Verify the reactive clearance at the rotor teeth end

Measure the reactive clearance at the end of the teething between the driven and driving rotors using a set of thickness shims.

Nominal reactive clearance at end:

0.060 – 0.160 mm

Reactive clearance limit at end:

0.21 mm

Replace the rotors if the active clearance recorded at the end is greater than the indicated limit.

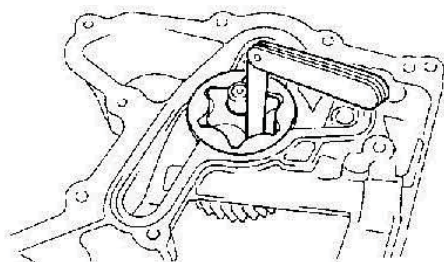
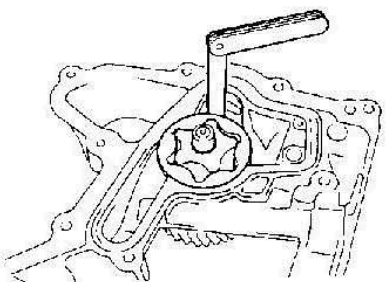

C. Verify the rotor side clearance

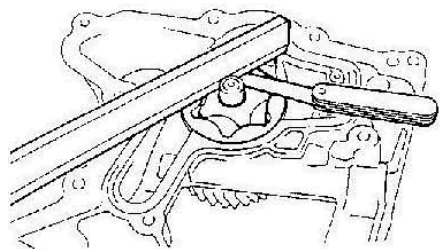

Use a set of thickness shims and a ground precision rule to measure the side clearance between the rotor and the ground precision rule.

Nominal side clearance:

0.030 – 0.090 mm

Limit side clearance:

0.15 mm

Replace rotors if the clearance recorded is greater than the indicated limit. If necessary, replace the complete oil pump.

REASSEMBLING THE OIL PUMP

(Refer to component part illustration for removal and reinstallation)

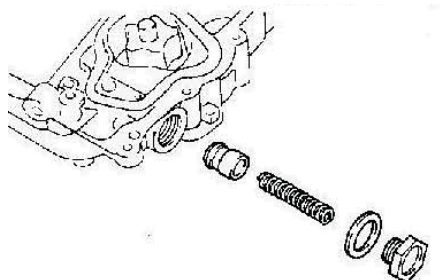

1. REINSTALL THE DISCHARGE VALVE

- a. Put the discharge valve and the spring in the assembly opening of the timing casing.
- b. Reinstall a new gasket and threaded cap.
- c.

Recommended tightening torque:
42 N.m (425 kgf.cm)

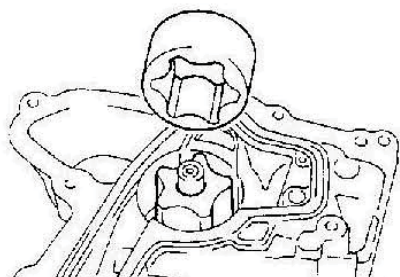

2. REINSTALL THE DRIVING AND DRIVEN ROTORS

REINSTALLING THE OIL PUMP (Refer to component part illustration for removal and reinstallation)

REINSTALLING THE OIL PUMP (TIMING CASING)

- a. Remove all signs of former sealant (FIPG) and take care not to dirty contact surfaces of the timing casing and cylinder block.

- * Use a razor blade and gasket scraper to remove any signs of former sealant (FIPG) on application surfaces.
- * Carefully clean all component parts so as to leave no signs of the former sealant.
- * Use a residue-free solvent to clean the application surfaces.

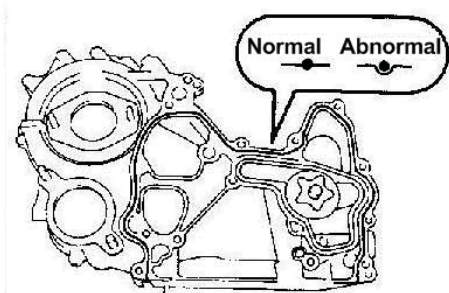

REMARK:

do not let the sealant fall on painted surfaces.

- b. Coat the timing casing with sealant at the locations illustrated in the figure opposite.

- * Put an application nozzle on the applicator and cut to diameter 3 to 5 mm.
- * Parts must be assembled within 3 minutes of applying the product, otherwise the sealant must be completely removed and applied again.
- * Immediately remove the application nozzle from the tube and screw back the closing cap when application of the product is completed.

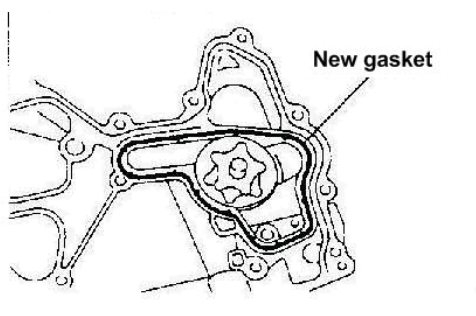

- c. Reinstall a new gasket in the timing casing groove at the location illustrated in the figure opposite.

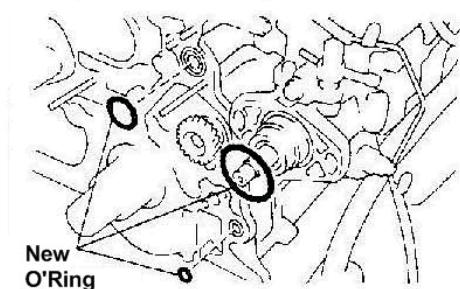

- d. Reinstall three new o-rings in the cylinder block and In the injection pump

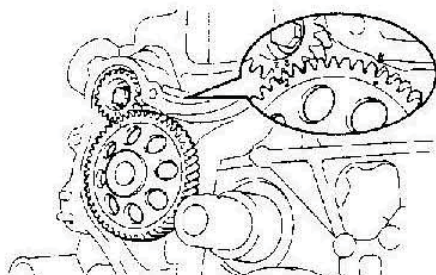

- e. Reinstall the distribution casing.
- f. Make the mark made on the driven pinion of No.1 balancing shaft correspond with mark "2".
- g. Make the mark made on the oil pump drive pinion coincide with the mark made on the timing casing.

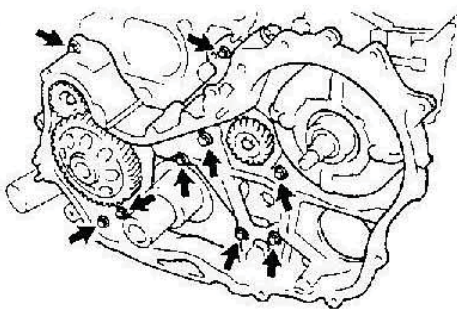

- h. Reinstall the eight assembly bolts and the coupling bolt.

**Recommended tightening torque:
13 N.m (130 kgf.cm) for the assembly bolt
Recommended tightening torque:
16 N.m (160 kgf.cm) for the coupling bolt**

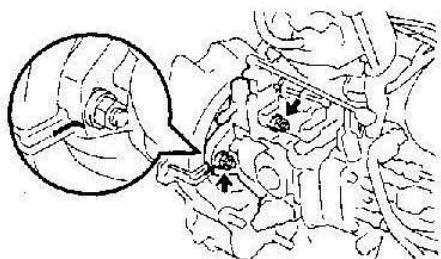

- i. Reinstall the two attachment nuts securing the injection pump to the timing casing.

Recommended tightening torque: 21 N.m (210 kgf.cm)

- ii. Verify the timing alignment on the injection pump (or the alignment marks) by inclining the injection pump.

PUT SOME OIL IN THE OIL PUMP

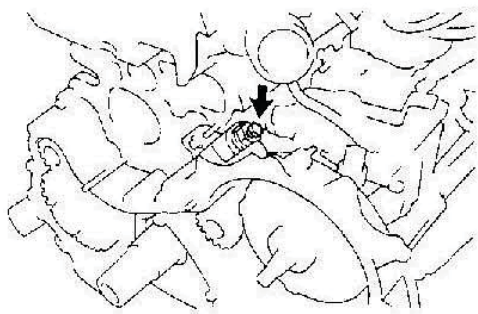

- a. Remove the tapered threaded plug.

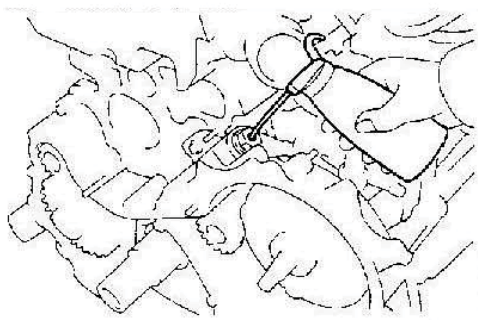

- b. Pour approximately 20 cm³ of engine oil in the oil pump.

- c. Coat two or three threads of the threaded section of the tapered threaded plug with sealant.

**Adhesive product:
LOCTITE 242 or similar product.**

- d. reinstall the tapered threaded plug

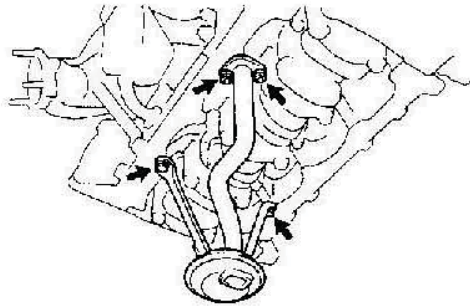
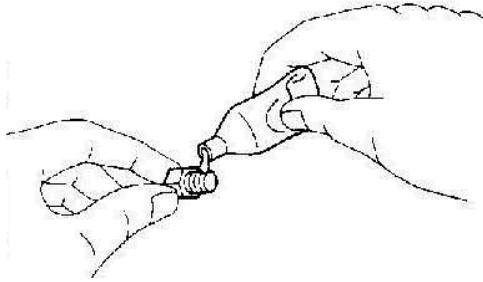

REINSTALL THE OIL STRAINER

Reinstall a new gasket at the oil strainer then secure with the two assembly bolts and the two attachment nuts.

Recommended tightening torque: 8 N.m (80 kgf.cm)

REINSTALL THE ENGINE LOWER CASING

- a. Remove signs of former sealant from the installation and take care not to dirty the application surfaces of the engine lower casing and the cylinder block.

- * Use a razor blade and gasket scraper to remove the slightest signs of sealant formed at the time of installation on gasket application surfaces and the sealant groove.
- * Carefully clean all component parts so as to leave no sign of the former sealant.
- * Use a residue-free solvent to clean application surfaces.

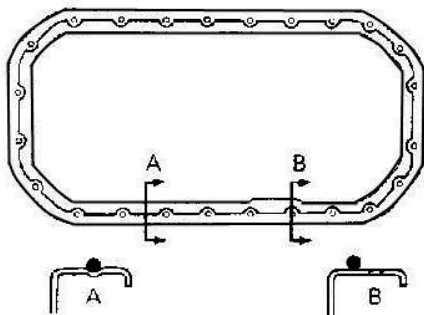

REMARK:

Do not use a solvent that could attack painted surfaces.

Coat the lower casing sealing parts as illustrated in the figure opposite.

- * Put an application nozzle on the applicator and cut to diameter 3 to 5 mm.

- * Parts must be assembled within 5 minutes of applying the product. If this time delay is exceeded, the product must be removed and application started again from the beginning.
- * Remove the application nozzle from the tube and put back the closing cap when application of the product is completed.

- b. Reinstall the engine lower casing with the twenty-two assembly bolts and the two attachment nuts.

Recommended tightening torque: 16 N.m (165 kgf.cm)

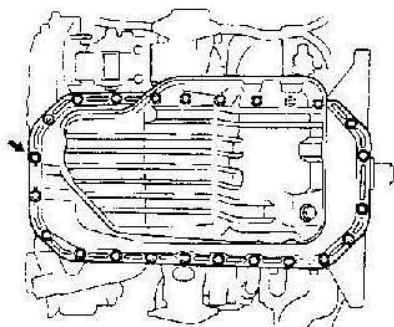

REINSTALL THE WATER PUMP

REINSTALL THE ALTERNATOR AND THE ALTERNATOR ATTACHMENT PLATE

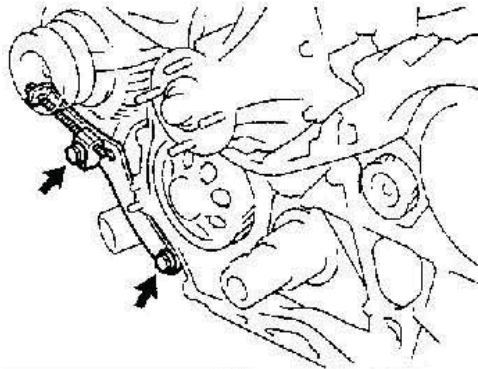

REINSTALL THE ALTERNATOR ADJUSTMENT BAR

Reinstall the adjustment bar with the assembly bolt and the lock bolt.

Recommended tightening torque:
21 N.m (210kgf.cm)

REINSTALL THE TIMING GEARS

REINSTALL THE TIMING BELT

REINSTALL THE WATER PUMP PULLEY AND THE DRIVE BELT

FILL THE ENGINE WITH ENGINE OIL

FILL THE ENGINE WITH COOLANT

START THE ENGINE AND VERIFY THAT THERE ARE NOT LEAKS

REPEAT THE ENGINE OIL LEVEL CHECK

OIL COOLER

Component part (removal and reinstalling)

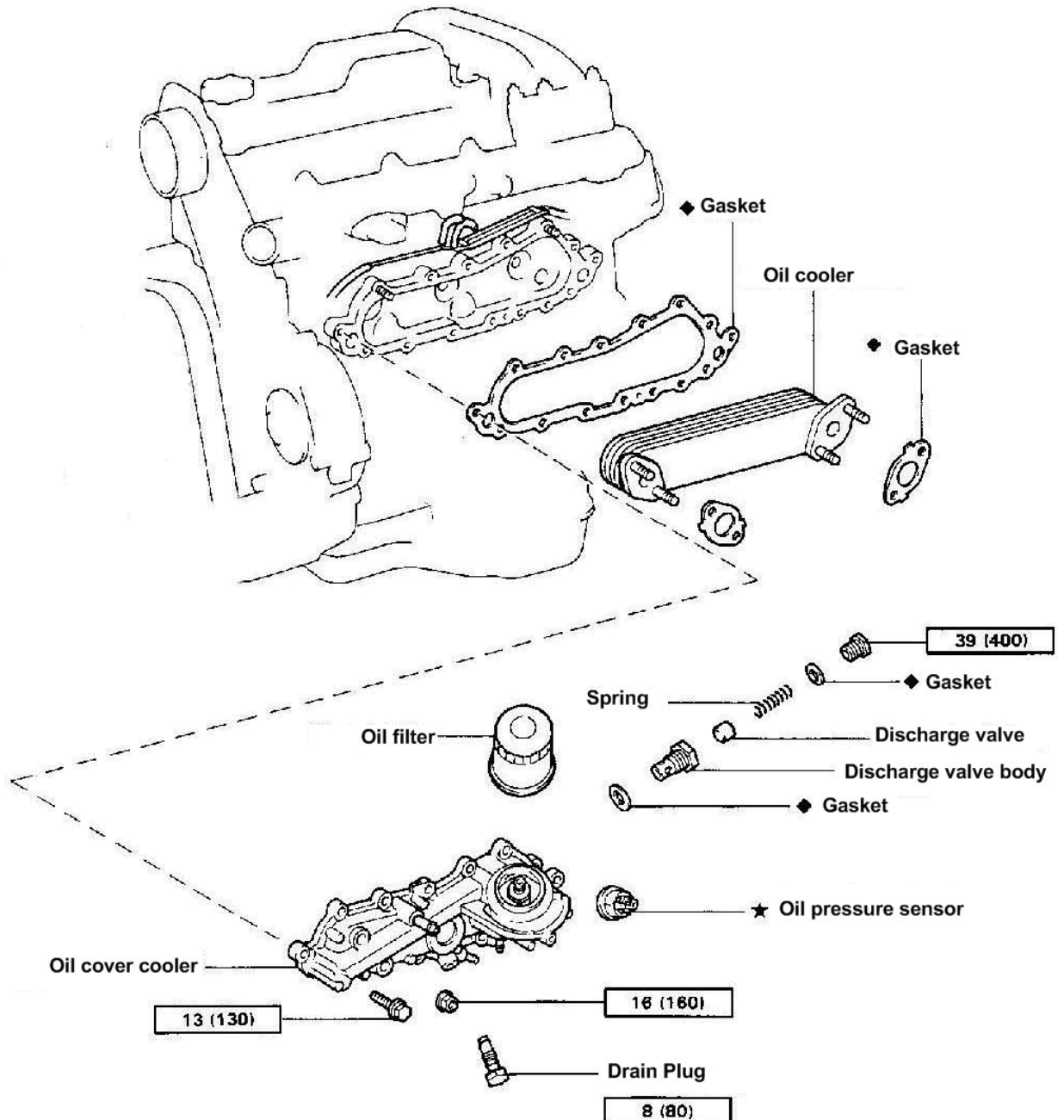

N.m (kgf.cm) : Specified tightening torque

◆ Non-reusable part

★ Pre coated part

REMOVING THE OIL RADIATOR AND THE DISCHARGE VALVE

1. DRAIN THE COOLANT FROM THE ENGINE
2. REMOVE THE TIMING BELT
3. REMOVE THE INJECTION PIPELINES
4. REMOVE THE INJECTION PUMP
5. REMOVE THE OIL LEVEL GAUGE AND ITS GUIDE
 - a. Remove the attachment nut and the oil level gauge guide assembly.
 - b. Remove the o-ring from the oil level gauge guide.

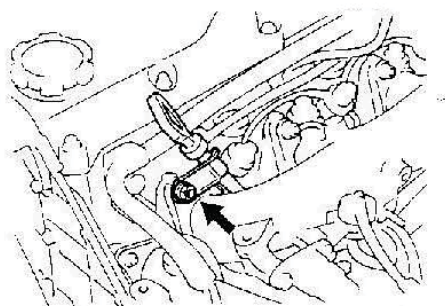

6. REMOVE THE OIL FILTER

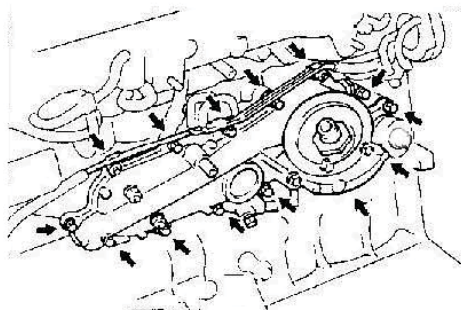

7. SEPARATE THE OIL RADIATOR FROM THE OIL RADIATOR CASING
 - a. Remove the two nuts and disconnect the negative pressure pipe.
 - b. Remove the sixteen assembly bolts, the oil radiator, the oil radiator cover and the gasket

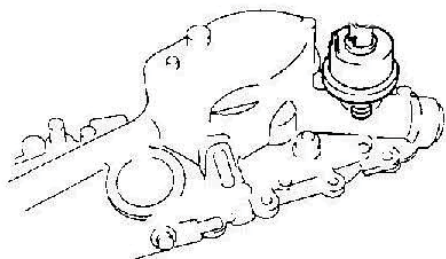

8. REMOVE THE OIL PRESSURE SENDER

9. SEPARATE THE OIL RADIATOR FROM THE OIL RADIATOR CASING

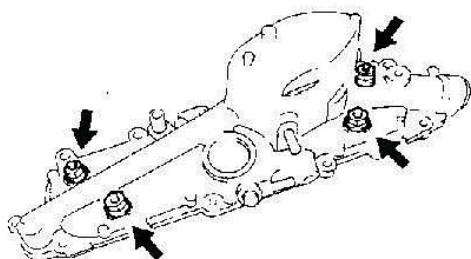

Remove the four nuts, the oil radiator, and the two seals from the oil radiator cover.

10. REMOVE THE DISCHARGE VALVE

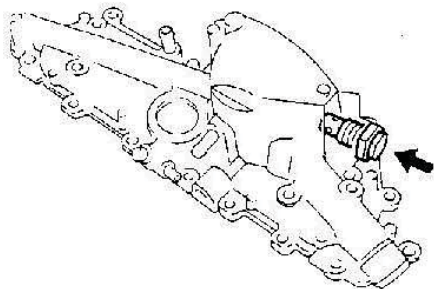

11. REMOVE THE OIL DRAIN PLUG

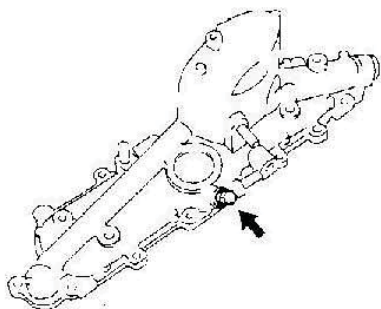

CHECKING THE OIL COOLER AND THE DISCHARGE VALVE

1. VERIFY THE DISCHARGE VALVE

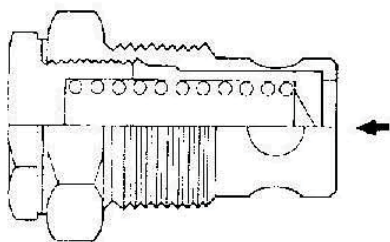

Push the discharge valve with a wooden stick and check that it is not stuck.

If it is stuck, replace it.

2. CHECK THE OIL RADIATOR

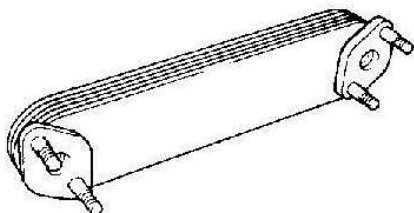

Check the amount of damage or clogging of the oil radiator. If necessary, replace the oil radiator.

REINSTALLING THE OIL RADIATOR AND THE DISCHARGE VALVE

(Refer to component part illustration for removal and reinstallation)

1. REINSTALL THE ENGINE OIL PLUG

Recommended tightening torque: 8 N.m (80 kgf.cm)

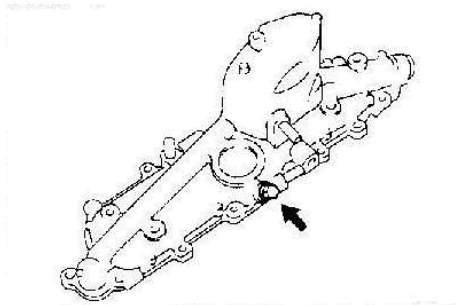

2. REINSTALL THE DISCHARGE VALVE

Reinstall a new gasket on the discharge valve.

Recommended tightening torque: 39 N.m (400 kgf.cm)

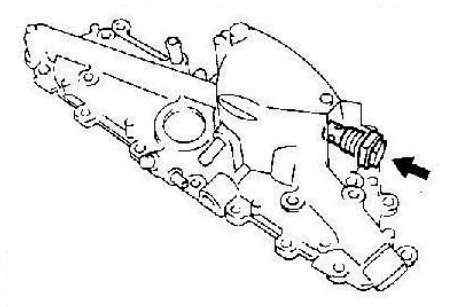

3. REINSTALL THE OIL COOLER AND THE OIL COOLER CASING

Reinstall two new seals on the oil radiator and the oil radiator casing and assemble with the four assembly bolts.

Recommended tightening torque: 16 N.m (160 kgf.cm)

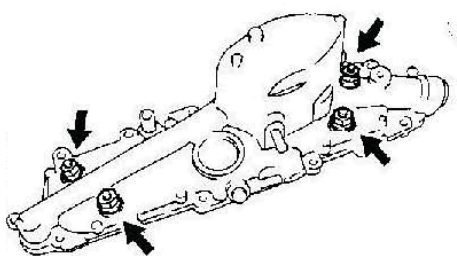

4. REINSTALL THE OIL PRESSURE SENDER

- a. Coat two or three threads of the oil pressure sender gauge with adhesive.

Adhesive product: LOCTITE 242 or equivalent product

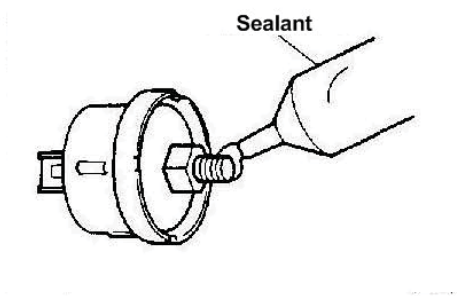

- b. Reinstall the oil pressure sender gauge

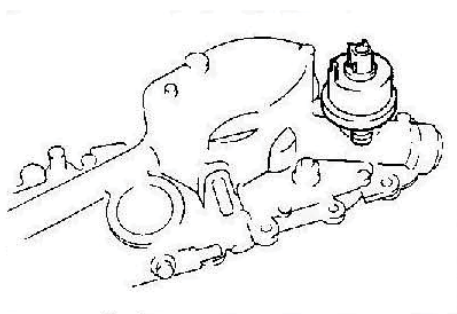

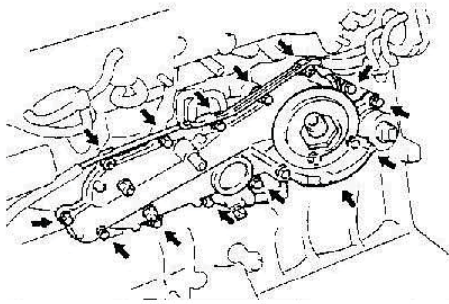

5. REINSTALL THE OIL COOLER AND THE OIL COOLER CASING ASSEMBLY

- a. Reinstall a new gasket, the oil radiator casing assembled to the oil radiator with the thirteen bolts.

Recommended tightening torque: 13 N.m (130 kgf.cm)

6. REINSTALL THE OIL LEVEL GUIDE AND THE OIL LEVEL GAUGE

Reinstall a new o-ring on the oil level gauge guide.

Reinstall the oil level gauge guide assembly with the attachment nut.

Recommended tightening torque: 29 N.m (300 kgf.cm)

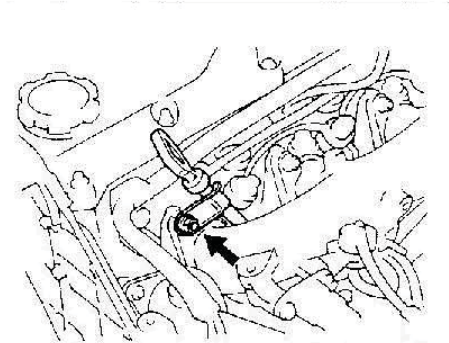
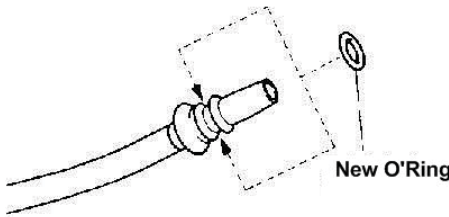

6. REINSTALL THE INJECTION PUMP

7. REINSTALL THE INJECTION PIPELINES

8. REINSTALL THE TIMING BELT

9. FILL THE ENGINE WITH COOLANT

10. START THE ENGINE AND CHECK WHETHER THERE ARE ANY LEAKS

11. CHECK THE ENGINE OIL LEVEL

TURBO-CHARGER

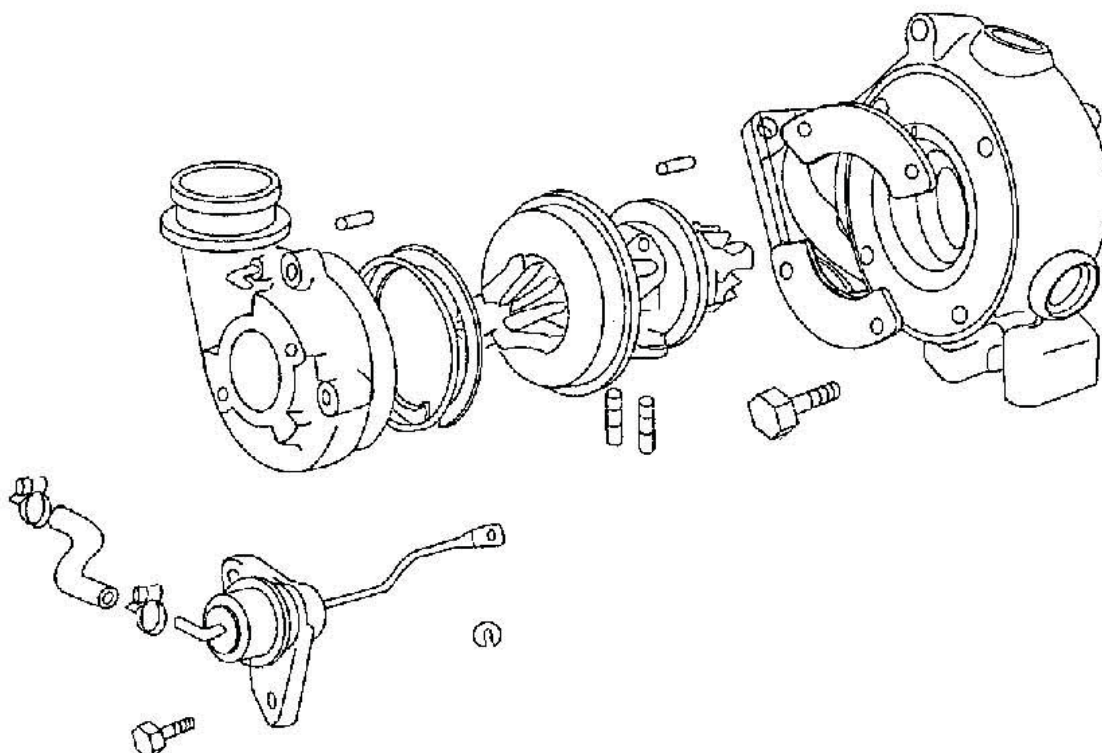

WARNING

**No component parts of
the turbo-charger
are available as spare parts**

**Whenever parts need replacing
the entire turbo-charger
needs to be replaced**

CHECKING THE TURBO CHARGER

1. CHECK ROTATION OF THE IMPELLER

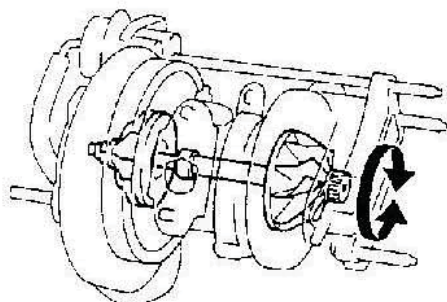

Take the edge of the turbine impeller and rotate it. Verify that the impeller turns without offering any resistance. If the impeller does not turn, or if it turns and rubs, replace the turbo charger.

2. CHECK THE AXIAL CLEARANCE OF THE IMPELLER

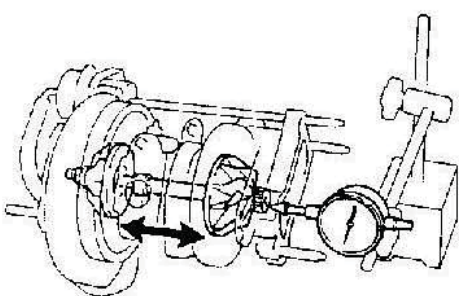

Put the dial gauge in the side intake hole of the impeller edge and check the axial clearance.

Maximum nominal clearance: 0.173 mm

If the axial clearance is not within the limits stipulated in the specification, replace the turbo charger.

3. CHECK THE RADIAL CLEARANCE OF THE IMPELLER

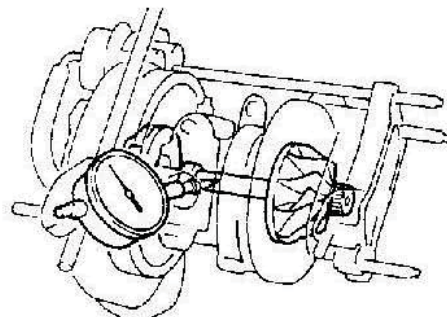

- a. Working from the oil delivery connector side, fit the dial gauge in the centre part of the impeller shaft.
- b. Move the impeller shaft in the radial direction and measure the radial clearance of the impeller shaft.

Maximum nominal clearance: 0.110 mm

If the radial clearance is not within the limits stipulated in the specification, replace the turbo charger.

4. CHECK OPERATION OF THE CONTROL DEVICE

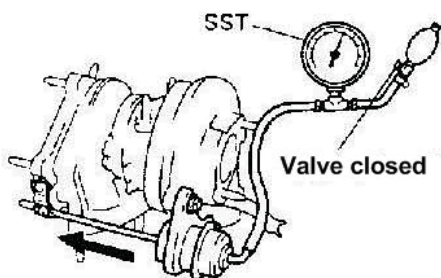

- a. Disconnect the flexible pipe of the control device.
- b. Use special maintenance tool SST to apply a pressure of approximately 116 kPa (1.18 kgf/cm²) to the control device and verify that the control rod moves.

If the control rod does not move, replace the complete turbo charger.

REMARK:

Never apply a pressure greater than 127 kPa (1.30 kgf/cm²) to the control device.

ENGINE BLOCK

Component parts (removal and reinstalling)

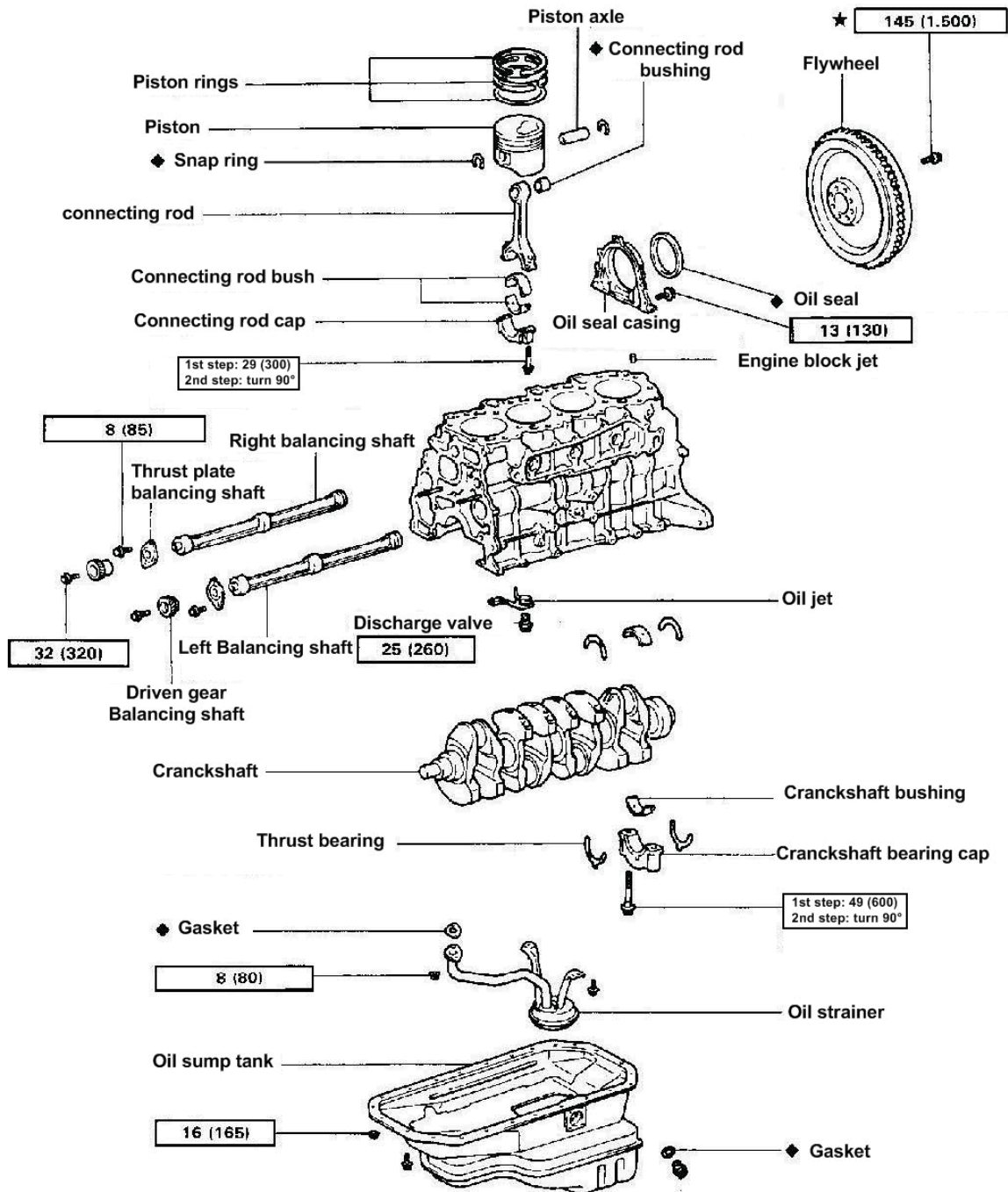

N.m (kgf.cm) : Specified tightening torque

◆ Non-reusable part

★ Pre-coated part

REMOVAL PREPARATION

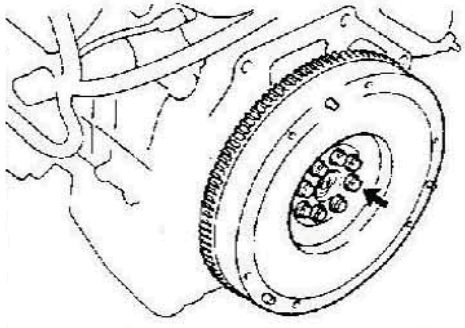

- 1- REMOVE THE ENGINE FLY WHEEL
- 2- INSTALL THE COMPLETE ENGINE ON AN APPROPRIATE SUPPORT IN ORDER TO DISASSEMBLE IT
- 3- REMOVE THE TIMING BELT AND THE TIMING PULLEYS
- 4- REMOVE THE CYLINDER HEAD
- 5- REMOVE THE ALTERNATOR AND THE ALTERNATOR ATTACHMENT PLATE
- 6- REMOVE THE WATER PUMP
- 7- REMOVE THE TIMING GEARS
- 8- REMOVE THE INJECTION PUMP
- 9- REMOVE THE ENGINE LOWER CASING AND THE TIMING GEAR CASING (OIL PUMP)
- 10-REMOVE THE OIL RADIATOR
- 11-REMOVE THE WATER INTAKE PIPELINE AND THE THERMOSTAT
- 12-REMOVE THE WATER TEMPERATURE SENSOR
- 13-REMOVE THE ENGINE SUSPENSION ATTACHMENT PLATE
- 14-REMOVE THE PLUG

DISASSEMBLING THE CYLINDER BLOCK (Refer to component part illustration for disassembly and reassembly)

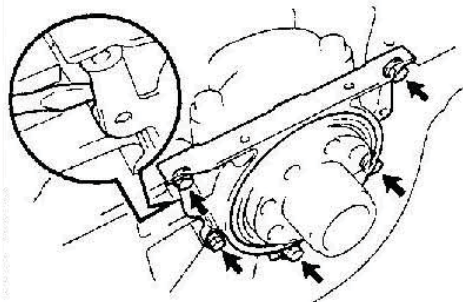

1. REMOVE THE REAR OIL GASKET RETAINING CAGE

Remove the five assembly bolts and the rear oil gasket retaining cage.

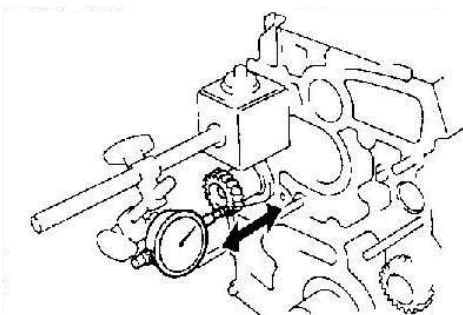

2. MEASURE THE AXIAL CLEARANCE OF THE LEFT AND RIGHT BALANCING SHAFTS OF THE MOTOR COMPENSATOR

Measure the axial clearance of the balancing shafts using a dial gauge and moving each balancing shaft backwards and forwards.

Nominal axial clearance: 0.065 – 0.140 mm

Axial clearance limit: 0.25 mm

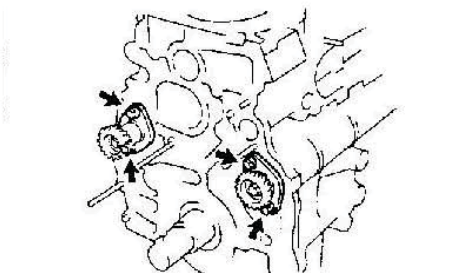

Replace the balancing shaft stop bush if the axial clearance limit is exceeded.

If necessary, replace the balancing shaft.

3. REMOVE THE LEFT AND RIGHT BALANCING SHAFTS

- a. Remove the two assembly bolts and the right balancing shaft.
- b. Remove the two assembly bolts and the left balancing shaft.

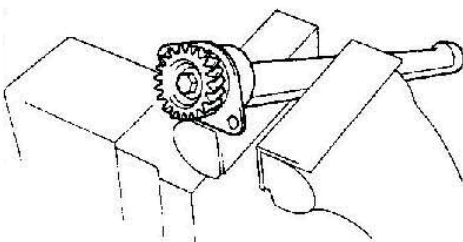

4. DISASSEMBLE THE LEFT AND RIGHT BALANCING SHAFTS

- a. Install the balancing weight of the balancing shaft in a vice.

REMARK:

Pay attention not to damage the balancing shaft during this work.

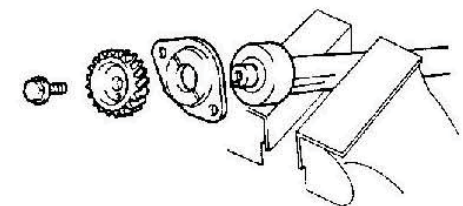

- b. Remove the assembly bolt, the balancing shaft driven pinion and the stop bush.

5. MEASURE THE CONNECTING ROD AXIAL CLEARANCE

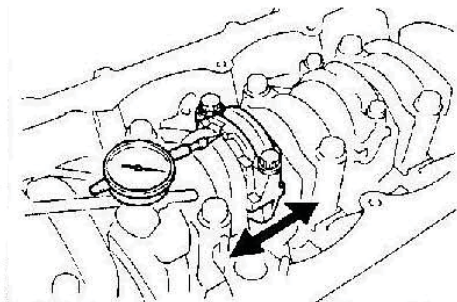

Measure the connecting rod axial clearance using a dial gauge while moving the connecting rod forwards and backwards.

Nominal axial clearance: 0.10 – 0.30 mm
Axial clearance limit: 0.40 mm

Replace the connecting rod when the axial clearance limit is exceeded. If necessary, replace the crankshaft.

6. REMOVE THE CONNECTING ROD CAPS AND MEASURE THE LUBRICATION CLEARANCE

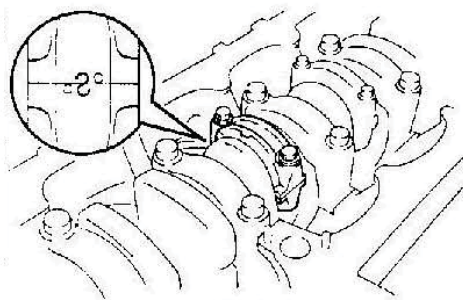

- a. Use a stamp or a numbering engraver to mark the alignment marks on the connecting rod and the connecting rod cap so as to prevent any confusion during reassembly.

- b. Remove the connecting rod cap assembly bolts.

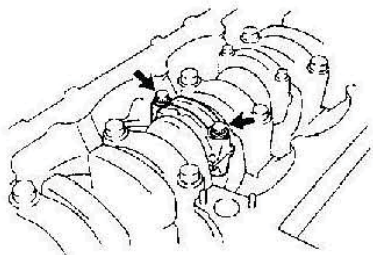

- c. Use the two connecting rod assembly bolts just removed as a lever on the connecting rod cap, from forwards to backwards and then remove the connecting rod cap.

ADVICE:

Keep the lower shell bearings fitted in the connecting rod caps.

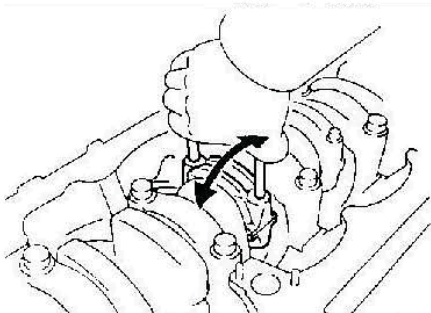

- d. Carefully clean the shell bearings and the crankshaft crank pins.
- e. Examine each shell bearing and each crank pin to detect any signs of pitting and scratches. Replace shell bearings when crank pins and shell bearings are damaged. If necessary, replace the crankshaft.

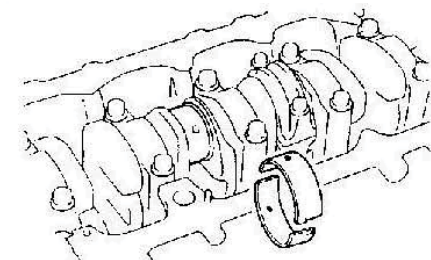

- f. Put a piece of plastigage over the crank pin of the crankshaft.

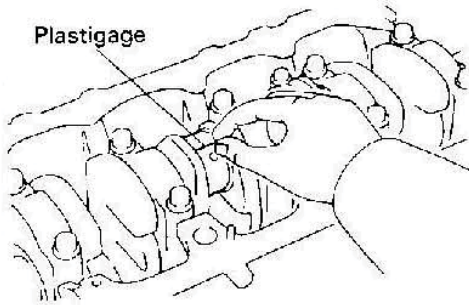

- g. Reinstall the connecting rod cap with the two assembly bolts.

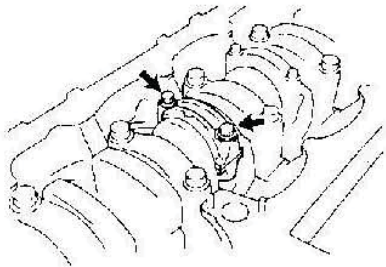

Recommended tightening torque:

First stage: 29 N.m (300kgf.cm)

2nd stage: Turn 90°

REMARK:

Make sure not to turn the crankshaft at this moment.

- h. Remove the two assembly bolts, the connecting rod cap and the lower shell bearing. (Refer to description in (b) and (c) previously).

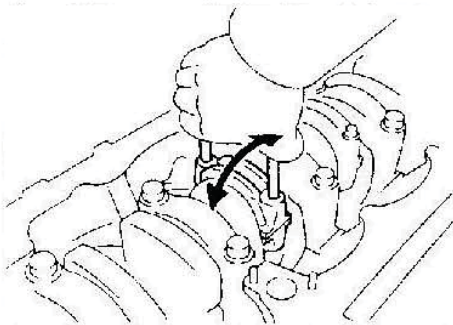

- i. Measure the plastigage at the largest location.

Lubrication clearance:

Nominal 0.036 – 0.054 mm

Dimension less than 0.25 and dimension less than 0.50: 0.037 – 0.077 mm

Clearance limit: 0.10 mm

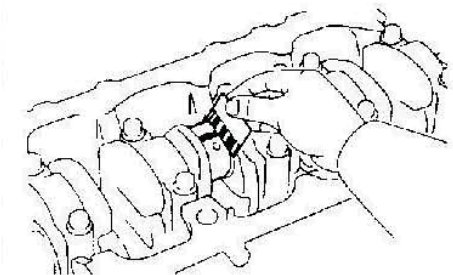

Replace the shell bearings if the clearance limit is exceeded. If necessary, replace the crankshaft.

ADVICE: When a standard shell bearing is used, replace it with a shell bearing of the same number. If it is not possible to determine the shell bearing number, choose an appropriate one by adding the numbers stamped on the connecting rod cap and the crankshaft, then select a shell bearing for which the number corresponds to the total of these numbers. There are five nominal shell bearing sizes, identified respectively by the numbers "2", "3", "4", "5" and "6".

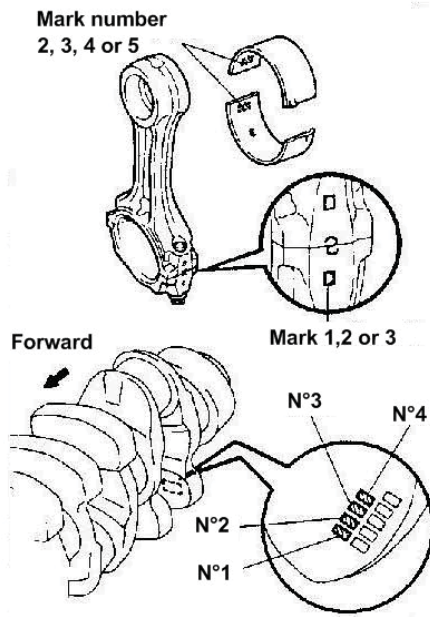

Cylinder block	Numbered mark								
	1			2			3		
Crankshaft	1	2	3	1	2	3	1	2	3
Shell bearing used	2	3	4	3	4	5	4	5	6

Example:
Cylinder block "2" + crankshaft "1" = total number 3 (use shell bearing "3")

Reference

Connecting rod small end inner diameter:

- Mark "1" 62.014 – 62.020 mm
- Mark "2" 62.020 – 62.026 mm
- Mark "3" 62.026 – 62.032 mm

Crankshaft crank pin diameter:

- Mark "1" 58.994 – 59.000 mm
- Mark "2" 58.988 – 58.994 mm
- Mark "3" 58.982 – 58.988 mm

Thickness of the standard size shell bearing centre wall:

- Mark "2" 1.486 – 1.489 mm
- Mark "3" 1.489 – 1.492 mm
- Mark "4" 1.492 – 1.495 mm
- Mark "5" 1.495 – 1.498 mm
- Mark "6" 1.498 – 1.501 mm

j. Carefully remove any signs of plastigage.

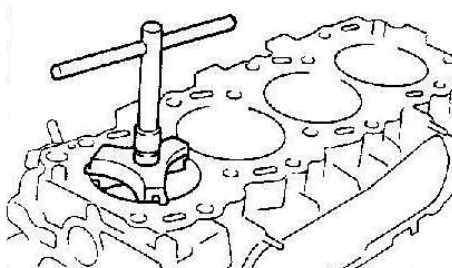

7. REMOVE THE CONNECTING ROD PISTON ASSEMBLY

- a. Remove carbon deposits found in the top parts of cylinders using a collar lifter.
- b. Drive out the piston assembly, connecting rod and upper shell bearing starting with the top part of the cylinder block.

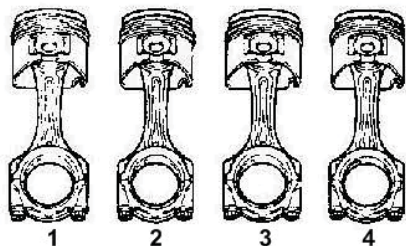

ADVICE:

- * Never separate the shell bearing from the connecting rod and the connecting rod cap.
- * Lay out piston-connecting rod assemblies in the disassembly order.

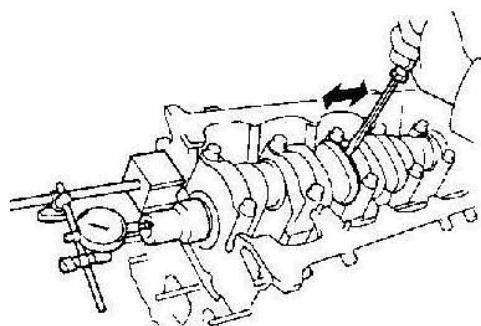

8. MEASURE THE CRANKSHAFT AXIAL CLEARANCE

Use a dial gauge to measure the crankshaft axial clearance while pushing it forwards and backwards using a screwdriver.

Nominal axial clearance: 0.040 – 0.240 mm
Axial clearance limit: 0.30 mm

Replace the stop shims using a set when the clearance limit is exceeded.

Axial shim thickness:
Nominal size 2.430 – 2.480 mm
Dimension less than 0.25 2.555 – 2.605 mm
Dimension less than 0.125 2.493 – 2.543 mm

9. REMOVE CRANKSHAFT BEARING CAPS AND VERIFY THE LUBRICATION CLEARANCE

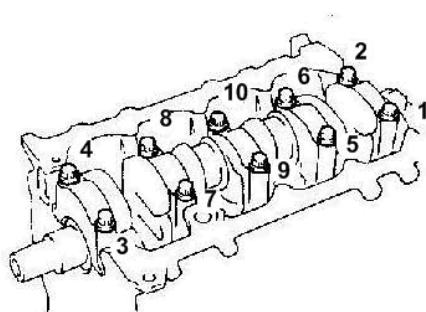

- a. Gradually loosen and remove the assembly bolts of the crankshaft bearing cap, working in several steps and in compliance with the order illustrated opposite.

- b. Use the bolts removed from the crankshaft bearing connecting rod cap as a lever moving the crankshaft bearing connecting rod caps backwards and forwards and remove the crankshaft bearing connecting rod caps, the lower shell bearings and the lower stop bushes (only on crankshaft No.5 bearing connecting rod cap).

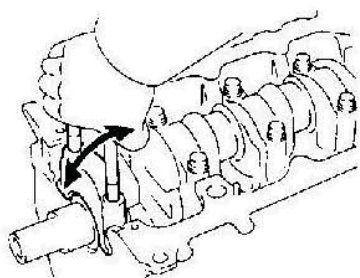

ADVICE:

- * leave the lower shell bearings fitted in the bearing cap.
- * lay out the bearing caps and lower end shims in the disassembly order.

c. Lift and remove the crankshaft.

ADVICE: Keep the upper shell bearings and the upper end shims in place in the cylinder block.

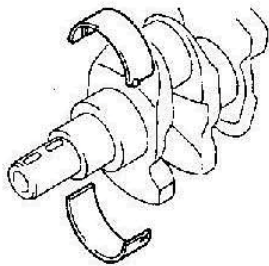
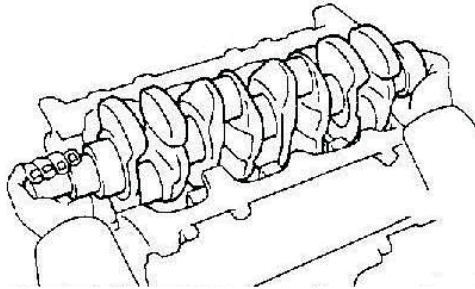

d. Carefully clean the pivot and the shell bearings.

e. Examine each pivot and the shell bearings for signs of pitting and scratching.

When a pivot or shell bearing is damaged, grind it or replace the crankshaft.

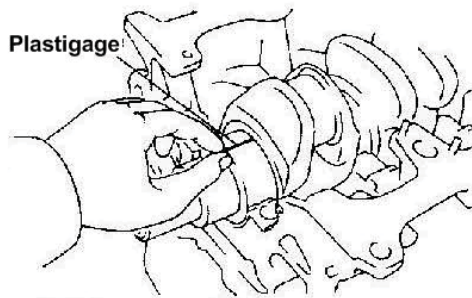

f. Reinstall the crankshaft in the cylinder block.

g. Put a strip of plastigage across the crankshaft pivot

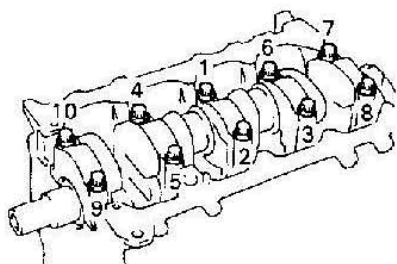

h. Reinstall the crankshaft bearing connecting rod cap.

Recommended tightening torque:

1st stage: 49 N.m (500kgf.cm)

2nd stage: Turn 90°.

REMARK:

Make sure not to turn the crankshaft at this moment.

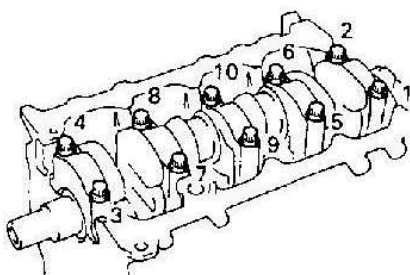

i. Remove the crankshaft bearing caps.
(Refer to descriptions (a) and (b) previously.)

j. Measure the widest part of the plastigage.

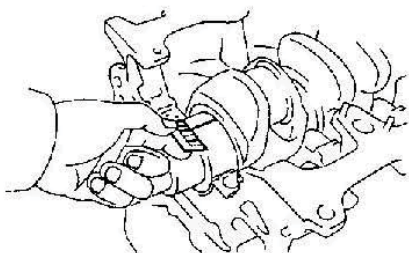

Lubrication clearance

Nominal: 0.036 – 0.054 mm
Dimension less than 0.25 and dimension less than 0.50: 0.037 – 0.077 mm
Clearance limit: 0.10 mm

ADVICE: If the cylinder block sub-assembly is replaced, the nominal clearance of the shell bearing will be as follows: **0.036 – 0.054 mm**

Replace crankshaft bearings if the lubrication clearance is greater than the indicated limit. If necessary, grind or replace the crankshaft.

ADVICE: When a standard shell bearing is used, replace it with a shell bearing of the same number. If it is not possible to determine the shell bearing number, choose an appropriate one by adding the numbers stamped on the connecting cylinder head and the crankshaft, then select a shell bearing for which the number corresponds to the total of these numbers. There are five nominal shell bearing sizes, identified respectively by the numbers "2", "3", "4", "5" and "6".

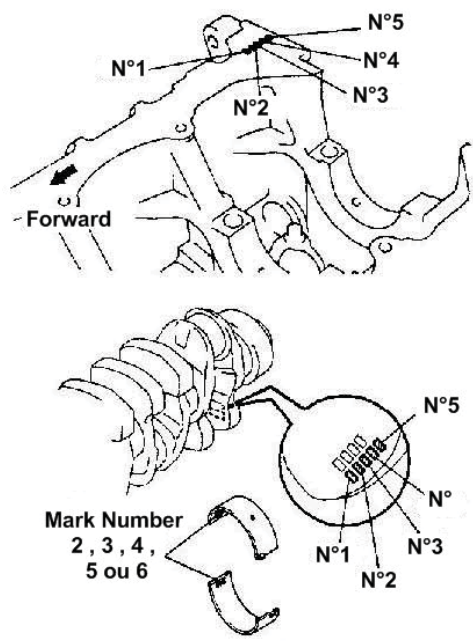

Cylinder block	Numbered mark								
	1			2			3		
Crankshaft	1	2	3	1	2	3	1	2	3
Shell bearing used	2	3	4	3	4	5	4	5	6

Example: Cylinder block "2" + crankshaft "1" = total number 3 (use shell bearing "3")

Reference

Cylinder block bearing pivot bore diameter:

Mark "1" 75.000 – 75.006 mm
Mark "2" 75.006 – 75.012 mm
Mark "3" 75.012 – 75.018 mm

Crankshaft bearing pivot diameter:

Mark "1" 69.994 – 70.000 mm
Mark "2" 69.988 – 69.994 mm
Mark "3" 69.982 – 69.988 mm

Thickness of the nominal shell bearing centre wall:

Mark "2"	2.479 – 2.482 mm
Mark "3"	2.482 – 2.485 mm
Mark "4"	2.485 – 2.488 mm
Mark "5"	2.488 – 2.491 mm
Mark "6"	2.491 – 2.494 mm

k. Carefully remove any signs of plastigage

10. REMOVE THE CRANKSHAFT

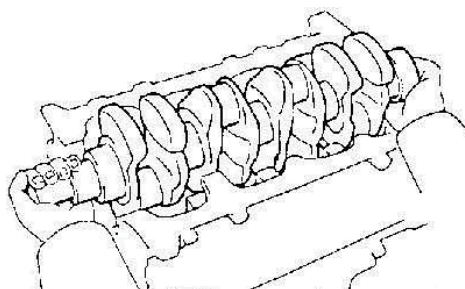

- a. Remove the crankshaft by lifting it up straight.
- b. Remove the upper shell bearings and the upper end shims from the cylinder block.

Upper bearing shell

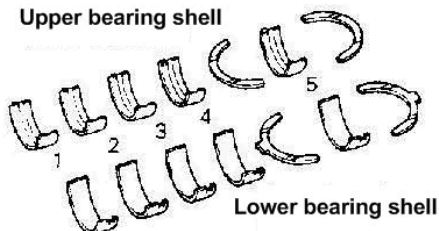

Lower bearing shell

ADVICE: Lay out crankshaft bearing caps, shell bearings and end shims in the logical disassembly order.

11. REMOVE CHECK VALVES AND INJECTORS

Remove the four check valves and the injectors.

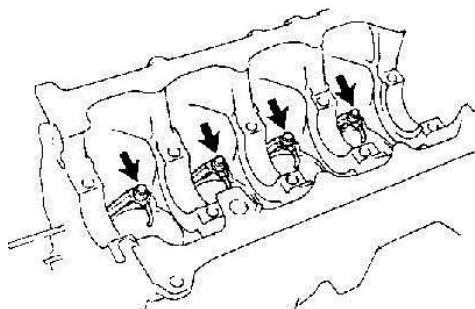

12. REMOVE THE CYLINDER BLOCK PORT

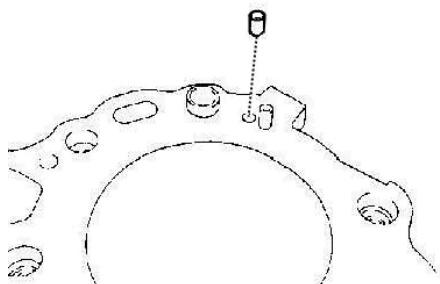

CHECKING THE CYLINDER BLOCK

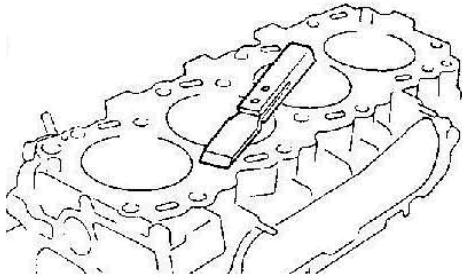

1. CLEAN THE CYLINDER BLOCK

A. Remove all signs of gasket

Use a scraper to remove all signs of sealant material, gasket, especially on the cylinder block assembly surface

B. Clean the cylinder block

Carefully clean the cylinder block using a soft bristle brush and a solvent.

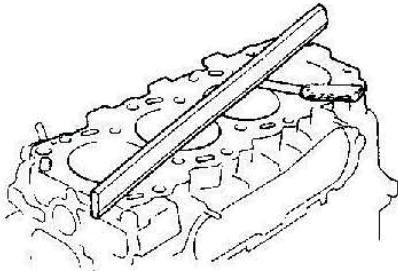

2. CHECK THE AMOUNT OF WARPING ON THE CYLINDER BLOCK TOP SURFACE

Use a straight precision rule and a set of thickness shims to measure the top contact surfaces of the cylinder block and check whether there is any deformation.

Warping limit: 0.10 mm

Replace the cylinder block when the amount of warping exceeds the indicated limit.

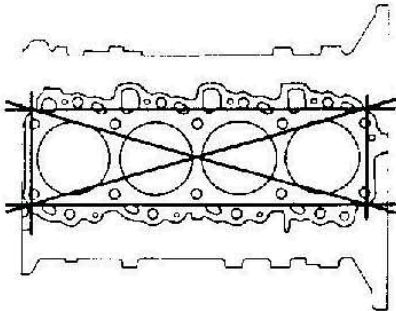

3. CHECK WHETHER CYLINDERS ARE SCRATCHED VERTICALLY

Visually examine the cylinders and check whether there are signs of vertical scratches on the walls.

Replace the four cylinders if deep scratches are found. If necessary, replace the cylinder block

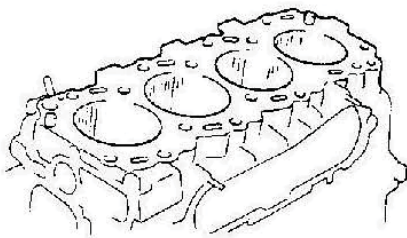

4. MEASURE THE CYLINDER BORE

ADVICE: There are three nominal bore diameters, respectively identified "1", "2" and "3".

The mark is stamped on the top surface of the cylinder block.

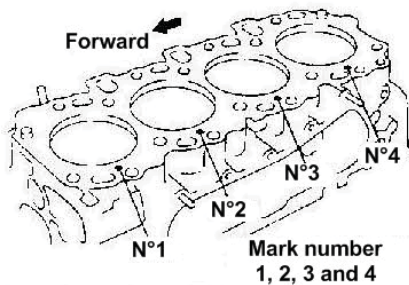

Use a cylinder diameter and measure the diameter of the bores of the cylinders at positions A, B and C and in the axial and stop directions.

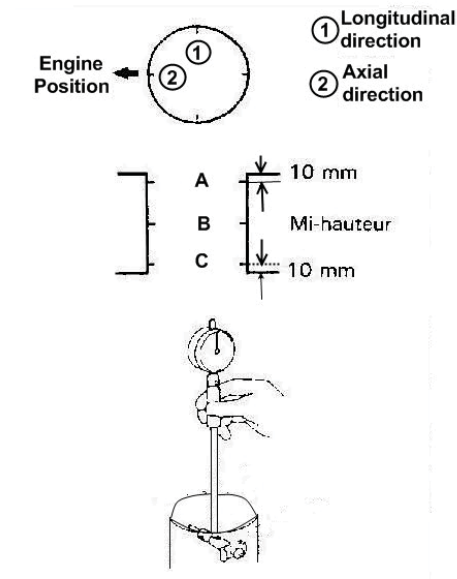

Nominal diameter:

Nominal	
Mark "1"	96.000 – 96.010 mm
Mark "2"	96.010 - 96.020 mm
Mark "3"	96.020 – 96.030 mm

Diameter Nominal Limit: 96.23 mm

Re-bore the four cylinders when the diameter limit is exceeded. If necessary, replace the cylinder block.

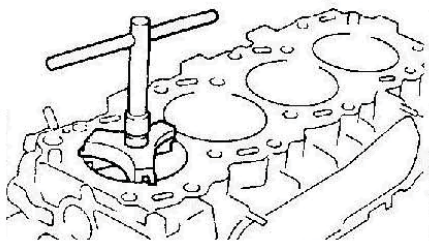

5. CUTTING CYLINDER COLLARS

When wear is less than 0.2 mm, obtain a collar-lifter to grind the top edge of the cylinder involved.

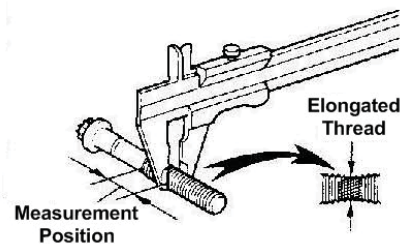

6. CHECK THE ASSEMBLY BOLTS OF THE CRANKSHAFT BEARING CAP

Use a Vernier caliper to measure the minimum dimension of the compressed section of the bolt thread at the location where the measurement must be made.

Nominal diameter:	13.500 – 14.000 mm
Diameter limit:	12.60 mm

Replace the attachment bolts with a diameter less than the specified limit.

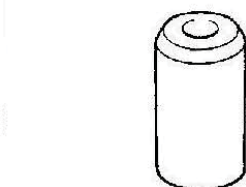

7. CHECK THE CYLINDER BLOCK PORT

Verify that the cylinder block port is not clogged

DISASSEMBLING CONNECTING-ROD PISTON ASSEMBLIES

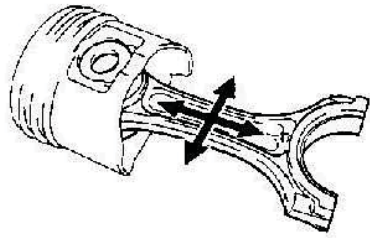

1. VERIFY THE ASSEMBLY CLEARANCE BETWEEN THE PISTON AND THE PIN

Move the piston backwards and forwards on its pin.
Replace the piston and its pin as a matched assembly when the clearance is recorded

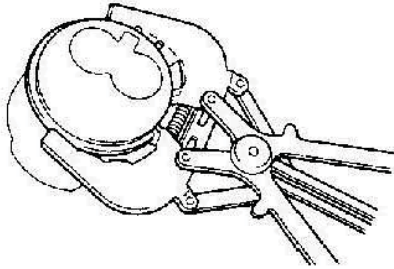

2. REMOVE THE PISTON RINGS

- a. Use a ring remover and remove the two compression rings of the piston and the oil scraper ring.

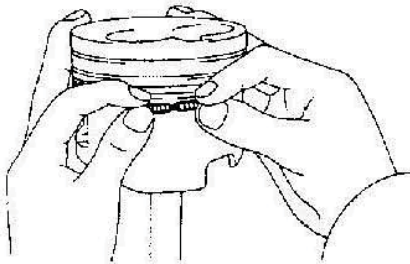

- b. Remove the expander manually.

ADVICE:

Keep the removed rings in the exact order.

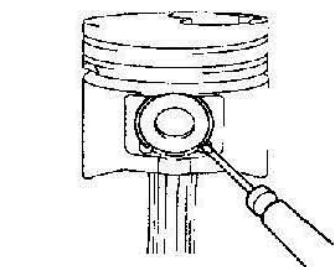

3. UNCOUPLE THE CONNECTING ROD AND THE PISTON

- a. Use a small screwdriver to prise off the snap ring and remove the piston

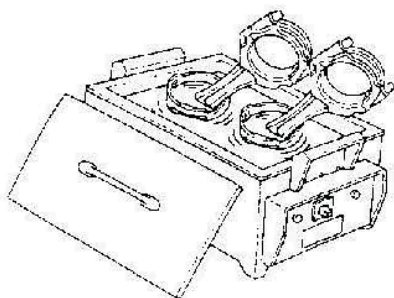

- b. Gradually heat the pistons in hot water at approximately 60°C

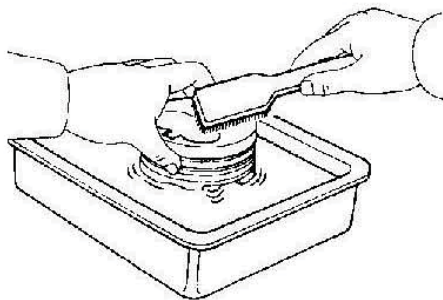
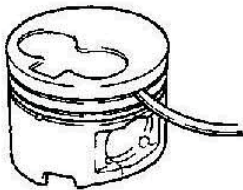
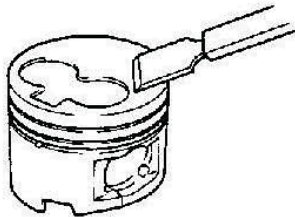
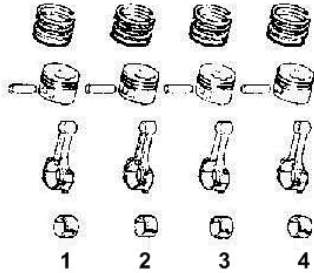
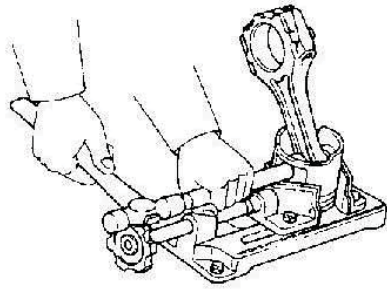

- c. Gently strike the piston pin to drive it from the piston using a plastic mallet and a brass mandrel

ADVICE:

- * Piston and pin make up a matched pair.
- * Lay out pistons, piston pins, rings and connecting rods in groups in compliance with the matched pair corresponding to each cylinder.

CHECKING THE CONNECTING ROD-PISTON ASSEMBLIES

1. CLEAN THE PISTONS

- a. Remove carbon deposits from the top of pistons with a scraper.
- b. Use a carbon deposit removal tool in grooves or where a ring is broken and remove carbon deposits from ring grooves.
- c. Carefully clean the piston with a solvent and a brush.

REMARK:
do not use a rasp.

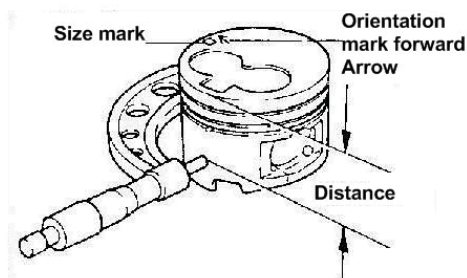

2. VERIFY THE PISTONS AND THE PISTON SEGMENTS

A. Verify the piston diameter and the piston lubrication clearance.

ADVICE: There are three nominal piston diameters, respectively identified "1", "2" and "3".
The mark is stamped on the top surface of the piston.

- a. With a micrometer, measure the diameter of the piston at right angles to the centre of the piston pin hole, at a distance of 58.8 mm from the piston head

Piston diameter:

Nominal

Mark "1"	95.940 – 95.950 mm
Mark "2"	95.950 - 95.960 mm
Mark "3"	95.960 – 95.970 mm

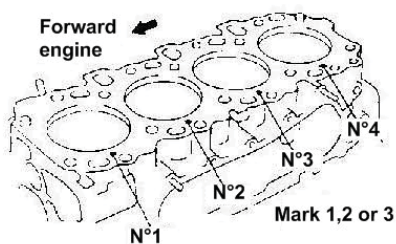

Upper dimension 0.50	96.440 -96.470 mm
Upper dimension 0.75	96.690 – 96.720 mm
Upper dimension 1.00	96.940 – 96.970 mm

- b. Measure the cylinder bore diameter in the stop direction.
- c. Subtract the piston diameter measurement from the cylinder bore diameter measurement.

Mark 1,2 or 3



Nominal lubrication clearance: 0.050 – 0.070 mm

Lubrication clearance limit: 0.14 mm

Replace the four pistons and re-bore the four cylinders if the lubrication clearance measurements are greater than the limits in compliance with specifications. If necessary, replace the cylinder block.

ADVICE (When a new cylinder block is installed): Use a piston with a numbered mark identical to the cylinder bore diameter stamped on the cylinder block.

Top compression ring

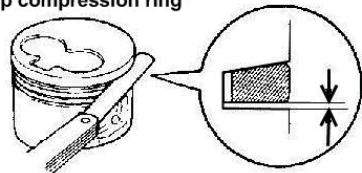

B. Measure the gap between the piston groove and the top compression ring:

Reinstall the top compression ring on the piston. Use a set of thickness shims to measure the gap between the new segment and the side of the piston groove.

Piston groove gap:

Top compression ring	0.060 – 0.110 mm
----------------------	------------------

Compression ring and oil scraper ring

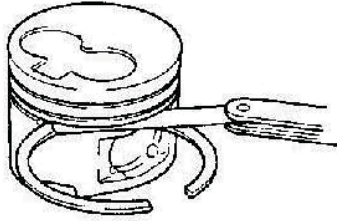

Compression ring and oil scraper ring.

Use a set of thickness shims and measure the gap between the new ring and the side of the piston groove.

Piston groove spacing:

Compression ring	0.060 – 0.100 mm
Oil scraper ring	0.020 – 0.060 mm

Replace the piston if the gap is greater than the limits.

C. Measure the segment gap

- a. Insert the measured ring in the cylinder bore.
- b. Use a piston to push the ring slightly into the cylinder under the stroke movement to 120 mm from the top surface of the cylinder block

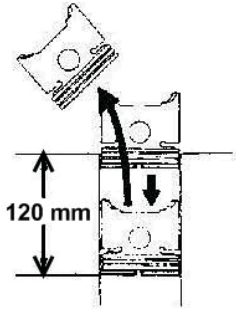

- c. Measure the ring gap using a set of thickness shims.

Nominal ring gap:

Top compression ring:	0.350 – 0.570 mm
Compression ring:	0.400 – 0.600 mm
Oil scraper ring:	0.200 – 0.500 mm
Ring cap limit	
Top compression ring:	1.03 mm
Sealing ring:	1.10 mm
Oil scraper ring:	0.87 mm

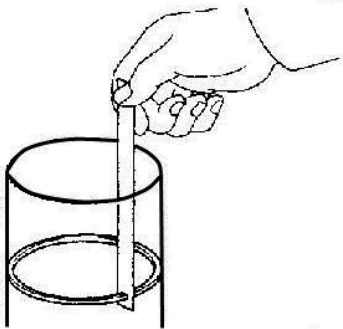

Replace rings when dimensions are not within the limits complying with specifications. If the ring gap is greater than the limit, even if the ring is new, re-bore the four cylinders or replace the cylinder block.

3. VERIFY PISTON RING FITTING

When the piston pin has been increased to a temperature of 80°C it must be possible to insert it in its piston by simply pushing it with your thumb.

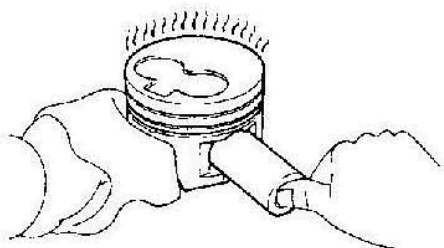

4. CHECKING THE CONNECTING RODS

A. Checking connecting rod straightness

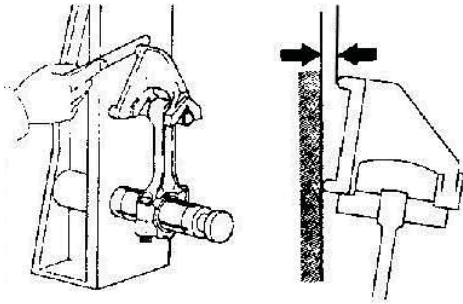

Check the straightness of connecting rods with a set of thickness shims by installing them on the connecting rod square.

- a) Check whether there is any bending.

Bending limit: 0.03 mm for 100 mm

Replace the connecting rod assembly when bending exceeds the indicated limit.

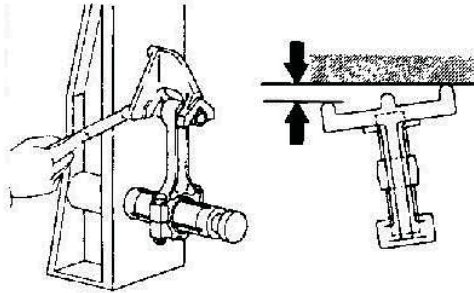

- b) Check for twisting

Twisting limit: 0.15 mm for 100 mm

Replace the connecting rod assembly when twisting exceeds the indicated limit.

B. Check the connecting rod assembly bolts

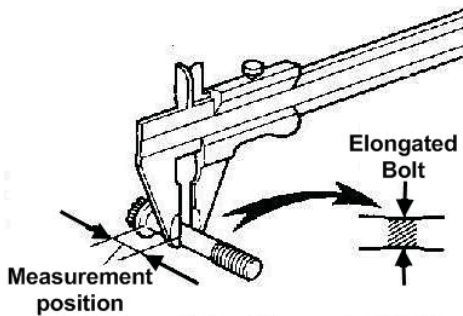

Use a Vernier caliper to check the minimum diameter of the compressed section of the bolt thread at the location where the measurement must be made.

Nominal diameter: 8.400 – 8.600 mm
Diameter limit 8.20 mm

Replace the connecting rod bolt when the diameter is less than the specified limit.

C. Check piston pin lubrication clearance

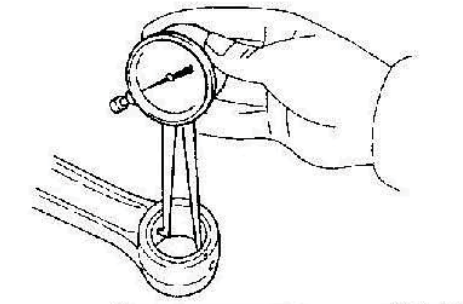

- a. Use a diameter measurement tool to measure the internal diameter of the connecting rod small end bush.

Inner diameter of the connecting rod small end bush: 34.012 – 34.024 mm

- b. Use a micrometer to measure the diameter of the piston pin.

Piston pin diameter: 34.000 – 34.012 mm

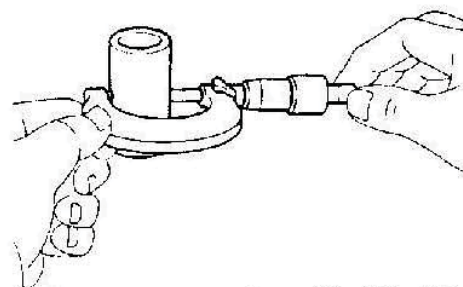

- c. Subtract the piston pin diameter measurement from the connecting rod small end bush internal diameter measurement.

Nominal lubrication clearance: 0.008 – 0.016 mm

Lubrication limits clearance: 0.03 mm

If the lubrication clearance is greater than the maximum dimension, replace the nozzle. If necessary replace the piston-connecting rod assembly.

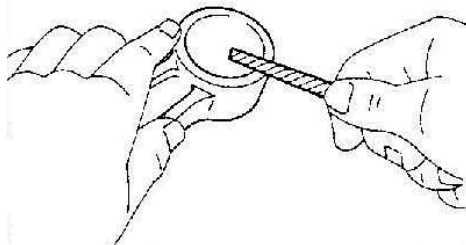
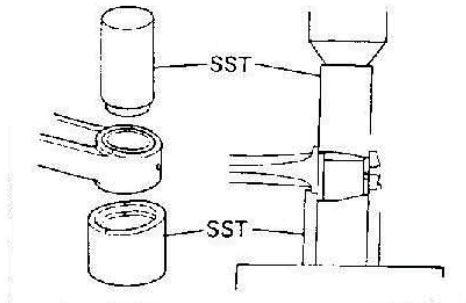

- D. If necessary, replace the connecting rod small end nozzles.

- Drive out the connecting rod small end nozzle using special maintenance tool SST and a press
- Use a fine file to slightly round off the connecting rod small end edge, working as illustrated in the figure opposite.

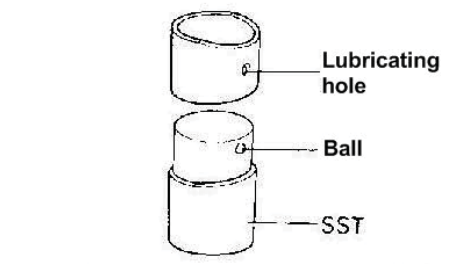

- Install the connecting rod small end nozzle on maintenance tool SST taking care to fit the rod of the special maintenance tool SST inside the lubrication hole of the nozzle.

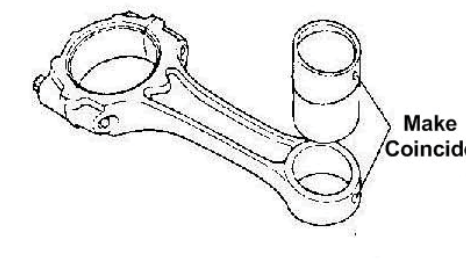

- Make the lubrication holes of the new connecting rod small end nozzle and the connecting rod coincide.

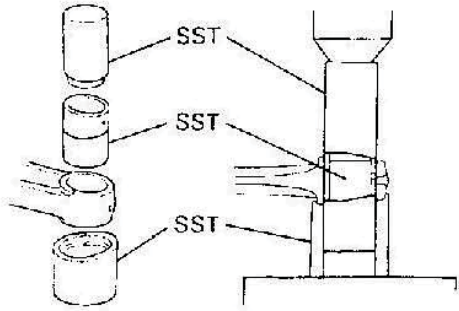

e. Fit the connecting rod small end nozzle in the connecting rod using special maintenance tool SST and a press.

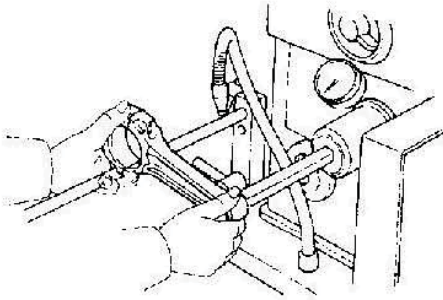

f. Use the piston pin bore reamer to ream the connecting rod small end nozzle to bring it to the nominal dimension between the nozzle and the piston pin (refer to operation C quoted above).

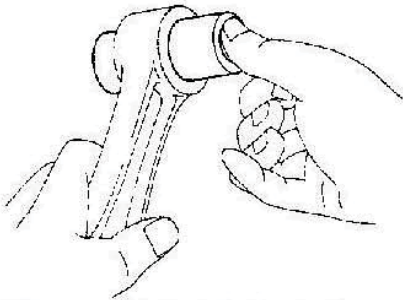

g. Check the piston pin assembly at the normal operating temperature of the part. Coat the piston pin with engine oil and fit the pin in the connecting rod using the pressure produced by the thumb.

CHECKING BALANCING SHAFTS

CHECK RIGHT AND LEFT BALANCING SHAFTS

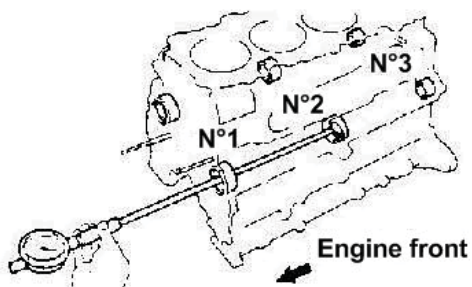

- a. Use a bore checker to measure the inside diameter of the balancing rod bearing.

Bearing inside diameter (measured from the front of the engine).

No.1:	42.000 – 42.020 mm
No.2:	41.000 – 41.020 mm
No.3:	32.000 – 32.020 mm

- b. Measure the external diameter of the balancing shaft bearing pivot.

External diameter of the bearing trunnion (measured from the front of the engine):

No.1:	41.941 – 41.960 mm
No.2:	40.931 – 40.950 mm
No.3:	31.941 – 31.960 mm

- c. Subtract the measurement of the balancing shaft bearing outside diameter from the balancing shaft bearing inside diameter.

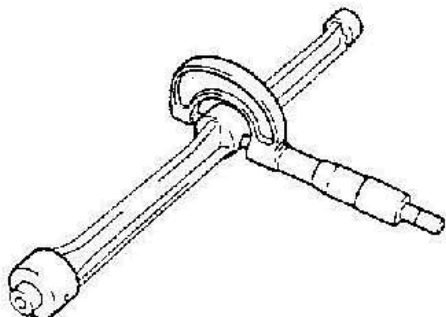

Nominal lubrication clearance:

No.1:	0.040 – 0.079 mm
No.2:	0.040 – 0.079 mm
No.3:	0.050 – 0.089 mm

Limit lubrication clearance:

No.1:	0.18 mm
No.2:	0.19 mm
No.3:	0.18 mm

Replace the cylinder block and the balancing shaft when the lubrication clearance limit is exceeded.

CYLINDER BORE

ADVICE:

- * Ream the four cylinders to bring them to the top diameter of the piston external diameter.
- * Replace worn rings to match them with the pistons at top diameter.

1. SELECT PISTONS AT TOP DIMENSION

Top dimension piston diameter:

Top dimension 0.50:	96.440 – 96.470 mm
Top dimension 0.75:	96.690 – 96.720 mm
Top dimension 1.00:	96.940 – 96.970 mm

2. CALCULATE THE AMOUNT OF MATERIAL TO REAM OUT IN THE CYLINDERS

- a. Using a micrometer, measure the diameter of the piston at right angles to the geometrical centre line of the piston pin hole and at the specified distance of 58.8 mm from the inner edge of the piston skirt.
- b. Calculate the amount of material to ream off in each cylinder using the following formula:

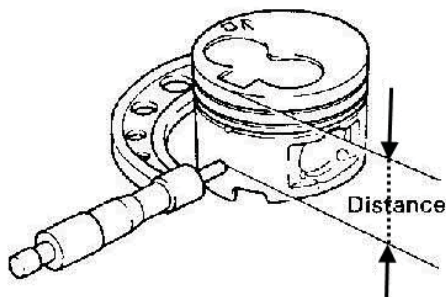

Amount of material to ream to reach the dimension = $P+C-H$

P = piston diameter

C = Piston clearance: 0.050 – 0.070 mm

H = running in tolerance: Less than 0.02 mm

3. REAM AND LAP CYLINDERS AT CALCULATED DIMENSIONS

Maximum lap value: 0.02 mm

REMARK:

Do not lap too fast otherwise the circular finish may be damaged.

CHECKING AND RECONDITIONING OF THE CRANKSHAFT

1. MEASURE THE CRANKSHAFT OUT OF ROUNDNESS

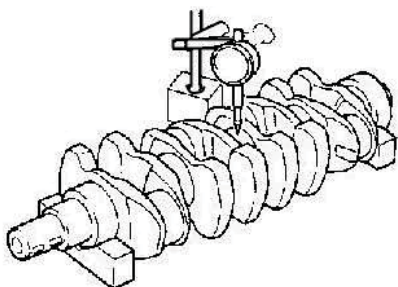

- a. Install the crankshaft on V blocks
- b. Use a dial gauge to measure the circular out of roundness of the centre pivot

Out of roundness limit: 0.06 mm

Replace the crankshaft when the out of roundness is greater than the indicated limit.

2. CHECK THE CRANKSHAFT CRANK PINS AND PIVOTS

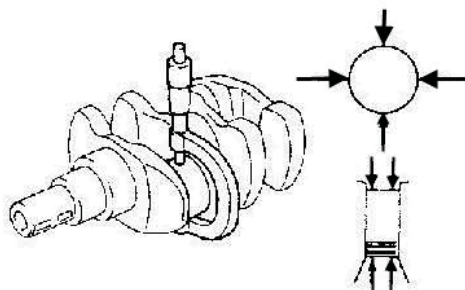

- a. With a micrometer, measure the diameter of each pivot and crank pin of the crankshaft.

Crankshaft pivot diameter:

Nominal	69.982 – 70.000 mm
Dimension less than 0.25	69.745 – 69.755
Dimension less than 0.50 mm	69.495 – 69.505 mm

Diameter of the crankshaft crank pin:

Nominal	58.982 – 59.000 mm
Dimension less than 0.25	58.745 – 58.755
Dimension less than 0.50 mm	58.495 – 58.505 mm

Verify the lubrication clearance when the diameter is not within the limits recommended by specifications.

If necessary, grind or replace the crankshaft.

- b. Check the taper and out of roundness of each trunnion and each crank pin of the crankshaft, working as illustrated in the figure opposite.

Taper and out of roundness limit: 0.020 mm

Replace the crankshaft when the taper and out of roundness limit is exceeded.

3. IF NECESSARY, GRIND AND LAP CRANK PINS AND/OR PIVOTS.

Grind and lap crank pins and/or pivots of the crankshaft to the lower machining dimension (refer to the procedure indicated in 2). Reinstall a new crank pin and/or new crankshaft

REPLACING THE CRANKSHAFT OIL GASKET

ADVICE:

There are two methods for replacement of oil seals (A and B) as described below:

REPLACING THE CRANKSHAFT REAR OIL GASKET

- A. When the rear oil gasket retaining cage is separated from the cylinder block:*
- Drive out the oil gasket using a screwdriver and a hammer.
 - Reinstall the new oil gasket using special maintenance tool SST and a hammer, then strike the tool until the gasket is flush with the edge of the rear oil gasket retaining cage.
 - Coat the lip of the gasket with MP grease.
- B. When the rear oil gasket retaining cage is installed in the cylinder block:
- With a knife, cut the oil gasket lip.
 - Prise out the oil gasket using screwdriver as a lever.

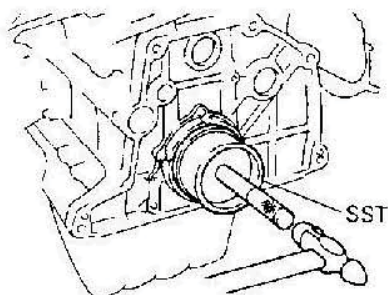
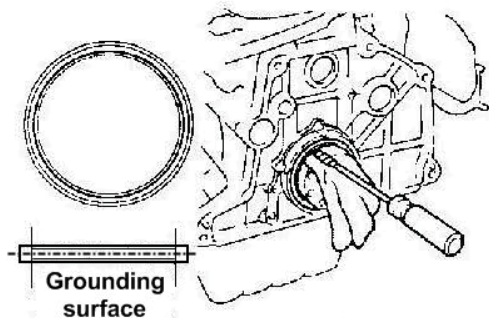
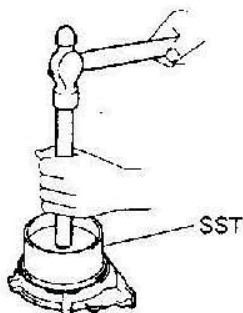
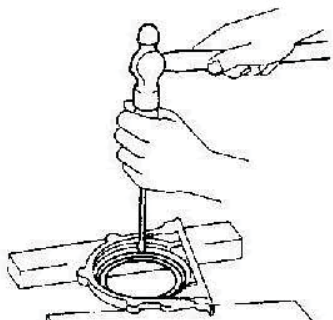

REMARK: Make sure not to damage the crankshaft during this operation. Coat the end of the screwdriver with adhesive tape for protection purposes.

- Coat the new oil gasket with MP grease.
- Reinstall the new oil gasket using special maintenance tool SST and a hammer and strike the gasket until it is flush with the edge of the rear oil gasket retaining cage.

REASSEMBLING THE PISTON-CONNECTING ROD ASSEMBLIES

1. REINSTALL THE PISTON-CONNECTING ROD ASSEMBLY

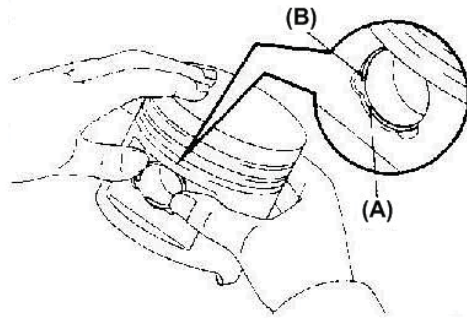

a. Reinstall the new spring on one side of the piston pin hole.

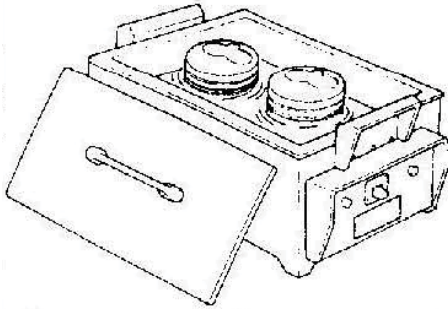

b. Gradually heat the piston until it reaches a temperature of approximately 80°C.

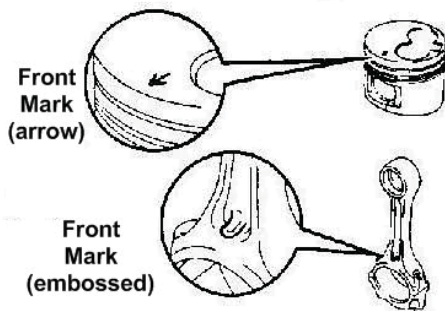

c. Coat the piston pin with engine oil.

d. Make the front mark of the piston and the connecting rod in line, and then push the piston pin into the piston with the pressure generated by the thumb.

e. Reinstall a new snap ring on the other end of the piston pin.

2. REINSTALL THE RINGS ON THE PISTON

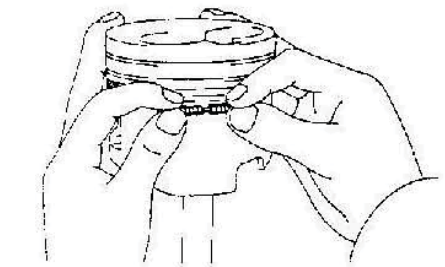

a. Reinstall the hand expander.

b. Reinstall the ring expander and the oil scraper ring.

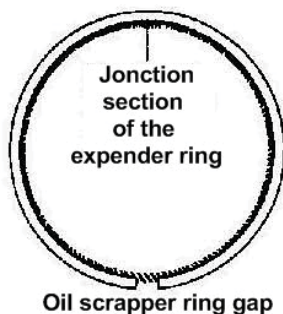

ADVICE:

Position the gap of the oil scraper ring on the side opposite the junction section of the expander ring.

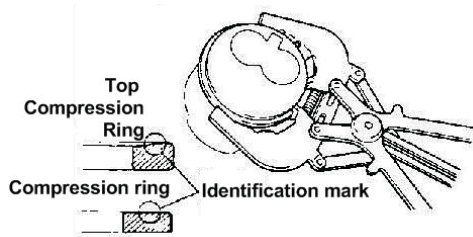

- c. Use the expanding ring spacing tool and install the two compression rings, taking care to position their identification marks upwards.

Identification mark:

Top compression ring: 1N

Compression ring: 2N

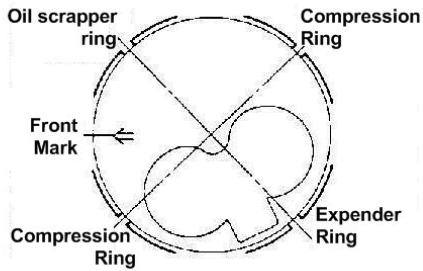

- d. Position the rings so that the ring gaps are positioned as illustrated in the figure.

REMARK:

Never put ring gaps in the same alignment.

3. REINSTALL THE SHELL BEARINGS

- a. Make the shell bearing rib coincide with the corresponding groove of the connecting rod or connecting rod cap.
- b. Reinstall the shell bearings in the connecting rod and connecting rod caps.

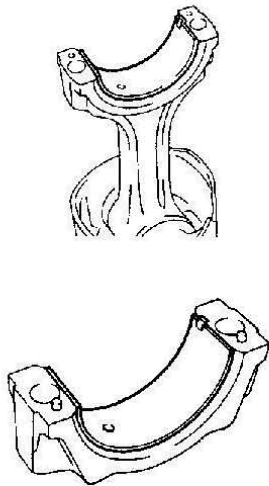

REASSEMBLING THE CYLINDER BLOCK (Refer to component part illustration for disassembly and reassembly)

ADVICE:

- * Carefully clean all parts to reinstall.
- * Before reassembling parts, coat all sliding and rotating surfaces with fresh engine oil.
- * Replace any linings or oil seals with new parts.

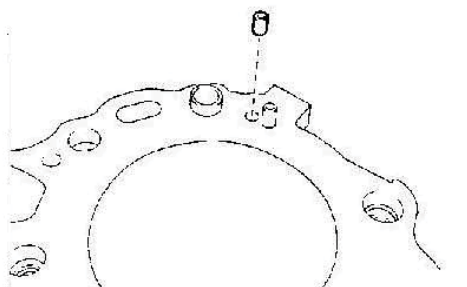

1. REINSTALL THE CYLINDER BLOCK OIL JET

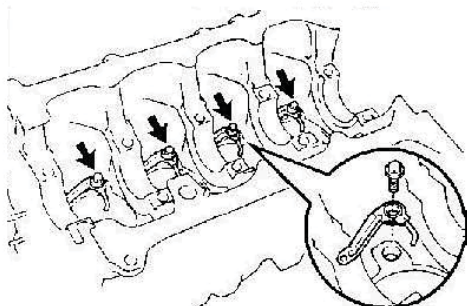

2. REINSTALL THE INJECTORS AND CHECK VALVES

- a. Make the needle of the injector coincide with the cylinder block needle hole.
- b. Reinstall each injector with its check valve. Reinstall the four injectors and check valves.

Recommended tightening torque: 25 N.m (260 kgf.cm)

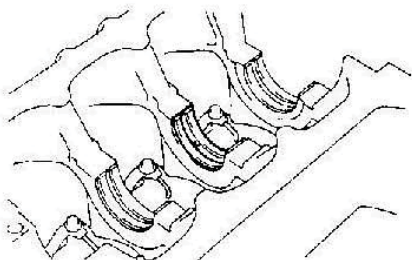

3. REINSTALL CRANKSHAFT BEARING SHELL BEARINGS

- a. Make the rib in the shell bearing coincide with the corresponding groove in the cylinder block and reinstall the five top shell bearings.
- b. Make the rib in the shell bearing coincide with the corresponding groove in the bearing cap, then reinstall the five lower shell bearings

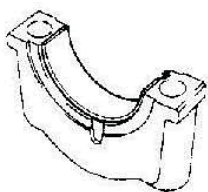

4. REINSTALL THE CRANKSHAFT ON THE CYLINDER BLOCK

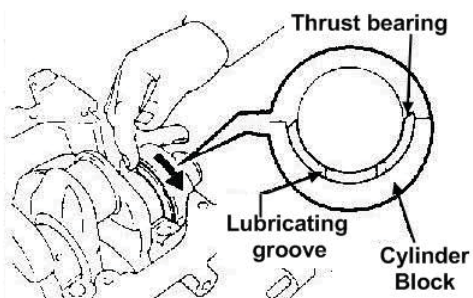
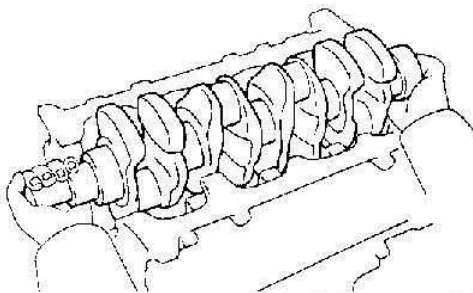

5. REINSTALL THE THRUST BEARING BUSHES

- a. Push the crankshaft forward (backward).
- b. Reinstall the two stop bushes under the crankshaft No.5 bearing cap on the cylinder block, taking care to orient the lubrication grooves towards the outside.

6. REINSTALL THE CRANKSHAFT BEARING CAPS AND THE LOWER THRUST BEARING BUSHES

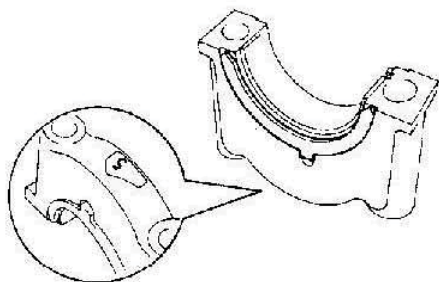

A) Reinstall the crankshaft bearing caps and the lower stop bushes on the cylinder block.

- a. Reinstall the two stop bushes on the crankshaft No.5 bearing cap, taking care to orient the lubrication grooves towards the outside.
- b. Reinstall the five bearing caps in their appropriate positions.

ADVICE: Each bearing cap is identified by a number and a front mark.

B) Reinstall the bearing cap assembly bolts.

ADVICE:

* The crankshaft bearing cap assembly bolts are tightened in two gradual stages (stages (b) and (d)).

* Replace the crankshaft bearing cap assembly bolts, which are broken or deformed.

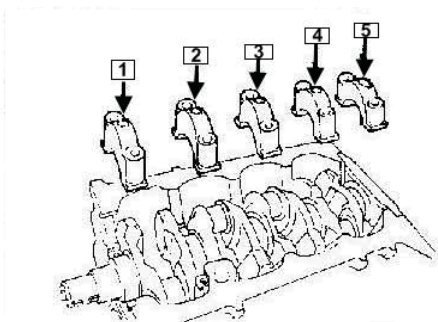

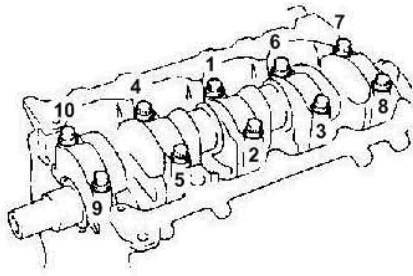

- a. Lightly coat the threading and the top of crankshaft bearing cap assembly bolts with engine oil.
- b. Reinstall and evenly tighten the ten assembly bolts of the crankshaft bearing caps to the torque indicated in compliance with the numbered tightening order, working in several stages.

Recommended tightening torque: 49 N.m (500 kgf.cm)

All crankshaft bearing cap nuts not in compliance with specifications must be replaced.

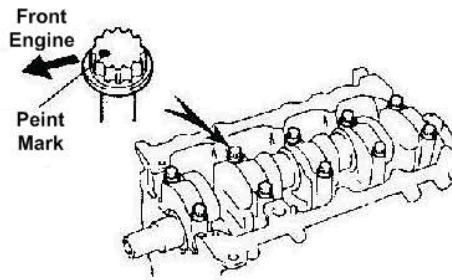

- c. Identify the front of the crankshaft bearing cap assembly bolts with paint.

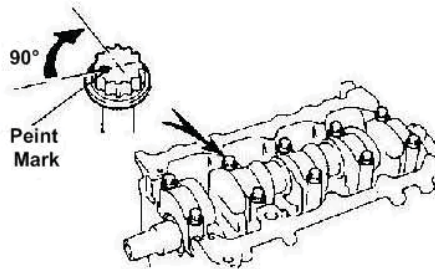

- d. Retighten the crankshaft bearing cap assembly bolts 90°, working in the numbered order opposite.
- e. Verify that the paint mark is still held directed 90° towards the front.
- f. Verify that the crankshaft turns normally.
- g. Measure the crankshaft thrust bearing clearance.

7. REINSTALL THE PISTON-CONNECTING ROD ASSEMBLIES

With a segment compression collar, correctly install each piston-connecting rod assembly in its corresponding cylinder in compliance with the matched pairing, taking care to direct the front mark of the piston head towards the front.

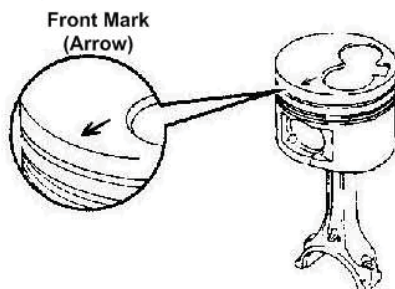
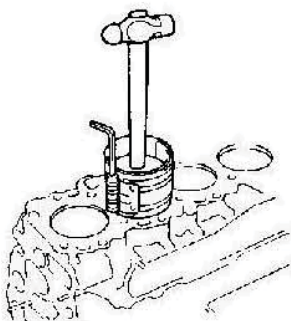

8. REINSTALL CRANKSHAFT BEARING CAPS

A. Reinstall the connecting rod cap on the crankshaft.

- Match the numbered caps with numbered connecting rods
- Make the front mark correspond to the front and reinstall the connecting rod cap.

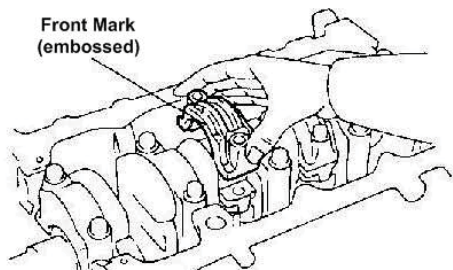

B. Reinstall the connecting rod cap bolts.

ADVICE:

- * The connecting rod cap assembly bolts are tightened in two gradual steps (step (b) and step (d)).
- * Replace the connecting rod cap bolts, which are broken or deformed.

- Lightly coat the thread on the top of the connecting rod cap bolt heads with engine oil.
- Reinstall and alternately tighten the connecting rod cap assembly bolts to the tightening torque indicated and work in several steps.

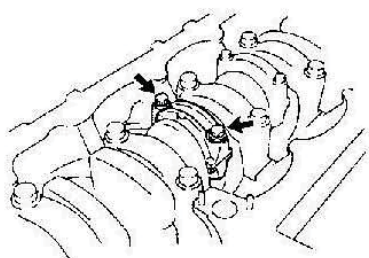

Recommended tightening torque: 29 N.m (300 kgf.cm)

All connecting rod cap bolts that do not comply with torque specifications must be replaced.

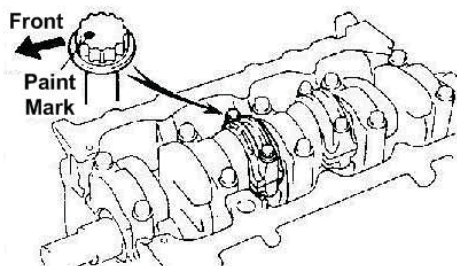

- Identify the front of the connecting rod cap bolt with paint.
- Retighten the connecting rod cap bolts 90° working in the numbered order indicated opposite.
- Check that the paint mark is now oriented 90° forward.
- Verify that the crankshaft rotates normally.
- Measure the connecting rod thrust clearance.

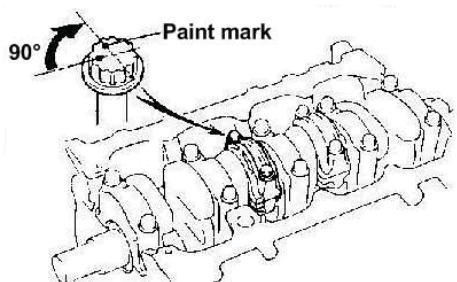

9. REINSTALL THE REAR GASKET RETAINING CAGE

- a. Remove all signs of the material making up the gasket (FIPG) taking care not to let oil fall onto the contact surfaces of the gasket retaining cage and the cylinder block.

* Use a razor blade and a scraper to remove all matter making up the gasket (FIPG) from gasket assembly surfaces and gasket grooves.
* Carefully clean all component parts to remove deposits.
* Use a residue-free solvent and clean all sealing surfaces.

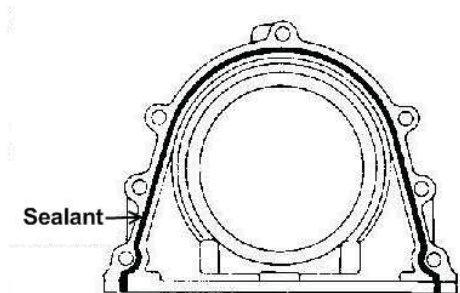

- b. Coat the sealant on the retaining cage, working as illustrated in the figure opposite.

* Install a nozzle cut to make a 2 to 3 mm opening.
ADVICE: Make sure not to put too much product.
* Parts must be assembled within the 5 following minutes of applying the product. Beyond this time, it is necessary to remove the applied sealant and start again.
* When the product application operation is completely finished, remove the nozzle and immediately put the cap back on the tube.

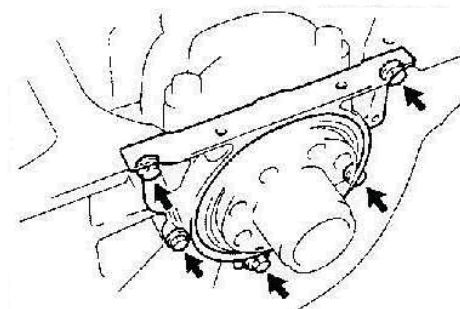

- c. reinstall the rear oil gasket retaining cage with the five assembly bolts.

Recommended tightening torque: 13 N.m (130 kgf.cm)

10. REINSTALL THE RIGHT AND LEFT BALANCING SHAFTS

- a. Install the balancing weights of the balancing shaft in a vice.

REMARK: Make sure not to damage the balancing shaft during this work.

- b. Make the assembly key of the balancing shaft coincide with the assembly key hole of the balancing shaft driven pinion, then reinstall the thrust washer and the balancing shaft driven pinion.
- c. Reinstall the assembly bolt and tighten to the recommended tightening torque.

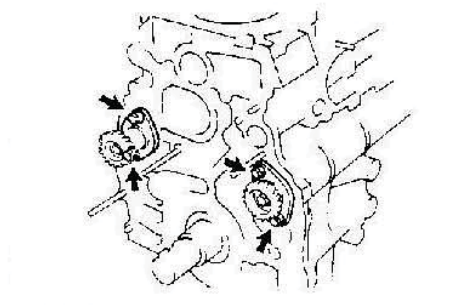
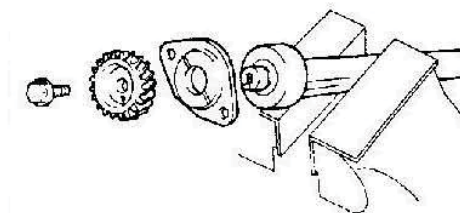

Recommended tightening torque: 32 N.m (320 kgf.cm)

11. REINSTALL THE LEFT AND RIGHT BALANCING SHAFTS

- a) Reinstall the right balancing shaft with the two assembly bolts.
- b) Reinstall the left balancing shaft with the two assembly bolts.

Recommended tightening torque: 8 N.m (85 kgf.cm)

POST-ASSEMBLY

1. REINSTALL THE PLUG
2. REINSTALL THE MOTOR SUSPENSION ATTACHMENT PLATE
3. REINSTALL THE WATER TEMPERATURE SENSOR
4. REINSTALL THE THERMOSTAT AND THE WATER INTAKE PIPES
5. REINSTALL THE OIL RADIATORS
6. REINSTALL THE ENGINE LOWER CASING AND THE TIMING GEAR CASING (OIL PUMP)
7. REINSTALL THE INJECTION PUMP
8. REINSTALL THE TIMING GEARS
9. REINSTALL THE WATER PUMP
10. REINSTALL THE ALTERNATOR AND THE ALTERNATOR ATTACHMENT PLATES
11. REINSTALL THE CYLINDER HEAD
12. REINSTALL THE TIMING BELT AND THE TIMING PULLEYS
13. REMOVE THE COMPLETE ENGINE FROM THE ENGINE TEST BENCH

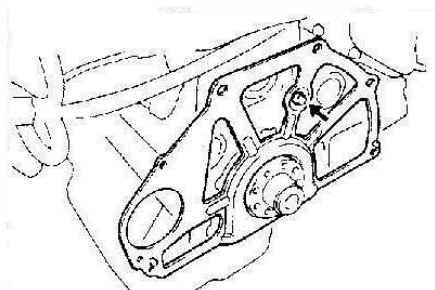

14. REINSTALL THE REAR CLOSING PLATE

Reinstall the rear closing plate with its assembly bolt.

Recommended tightening torque: 8 N.m (85 kgf.cm)

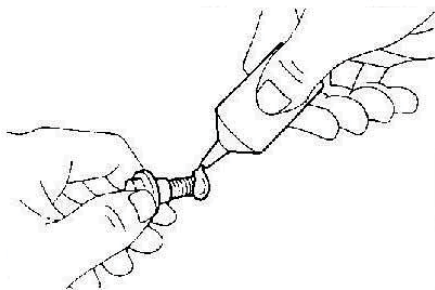

15. REINSTALL THE ENGINE FLY WHEEL

- a. Coat the threading of the cylinder head bolts over two or three threads with the sealant.
- b. Reinstall the fly wheel on the crankshaft.
- c. Reinstall and evenly tighten the assembly bolts to the recommended tightening torque in several stages and in the order indicated in the illustration.

**Recommended tightening torque:
145 N.m (1,480 kgf.cm)**

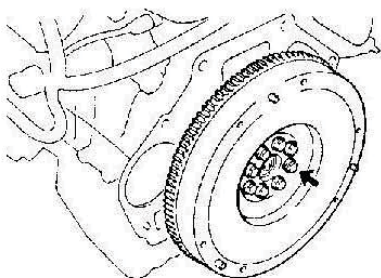

16. REINSTALL THE CLUTCH CLOSING PLATE AND THE DISK