



Elegance Taps & Showers

INSTALLATION & USER INSTRUCTIONS

Thank you for purchasing this Whale product.

For over 50 years, Whale has led the way in the design and manufacture of freshwater and waste systems including: pumps, plumbing faucets, showers for low voltage applications. The company and its products have built a reputation for quality, reliability and innovation backed up by excellent customer service.

SPECIFICATION

Product Codes	RT1010, RT2007, RT2010, RT2500
Voltage	12 V d.c. and 24 V d.c.
Recommended Fuse Size	5 Amp
Weight	Variable 0.195 - 0.450kg
Materials	Body: ABS, Spout: and Valves: Acetal, Seals: Neoprene
Accessories	<p>Marine Accessories: RT1270B Wall bracket</p> <p>RV Accessories: AS5133 Replacement handset ½" BSP AS5146 Replacement hose assembly 1.7m</p>
Service Kits (available separately)	<p>AK5030 Tap / Shower service kit AS5122 Tap / Shower upgrade kit - white AS5123 Combo handset - white AS5020 Elegance short outlet - white AS5125 Elegance long outlet - white AS5145 Shower hose kit - white AS5147 Shower hose 2.1m - white AS5149 Shower hose connection service kit - white AS5623 Combo handset - beige AS5625 Elegance long spout - beige AS5089 Elbow single tape service kit AS5626 Tap / shower upgrade kit - beige AS5146 Shower hose (½" BSP) - white AS5148 Hose for Swim'n'rinse AS5645 Shower hose kit - beige AS5649 Shower hose connector - beige</p>
Operating Temp Range	3 - 60°C
Storage Temp Range	-40 - 60°C

Whale's policy is one of continuous improvement and we reserve the right to change specifications without prior notice.

CONTENTS

1. Principles of Operation
2. Application
3. Warnings
4. Parts List
5. Optional Extras
6. Installation
7. Maintenance
8. Helpful Hints
9. Winterising
10. Service Support Details
11. Patents and Trademarks
12. Warranty

1. PRINCIPLES OF OPERATION

Elegance faucets are designed for use in low voltage mobile applications such as boats, caravans and motorhomes.

READ CAREFULLY BEFORE INSTALLATION AND USE

To the Fitter:

Check that the product is suitable for the intended application, follow these installation instructions and ensure all relevant personnel read the points listed below. Also ensure that these operating instructions are passed on to the end user and it is the user's responsibility to ensure that the materials are fully compatible with the liquids to be used and that a system of safe working practice is applied to installation use and maintenance.

To the User:

Please read the following carefully before installation.

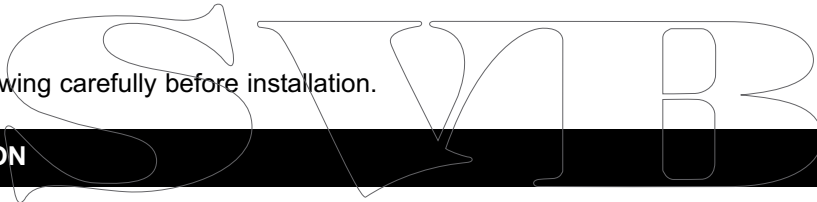

2. APPLICATION

Elegance taps or shower units are intended for use in fresh water systems in boats, caravans and motorhomes. Use for any other purpose or with any other liquid is entirely at the users' risk.

3. WARNINGS



WARNING

- Elegance faucets and showers **are not** suitable for installation in domestic appliances. Before starting to install this product, ensure that a system of safe working practice is applied to the installation and maintenance. Ensure the electric supply is turned off before commencing installation.
- Fire hazard – Wiring **MUST** comply with applicable electrical standards and include a properly sized fuse or circuit breaker. Improper wiring can cause fire resulting in injury or death. Suggested wiring information is given as a guide only.

4. PARTS LIST

Faucets, screws and screw caps.

5. OPTIONAL EXTRAS

WF1230, Water filter 12mm, and WF1250, Water filter 15mm, are available separately.
Tap / Shower replacement kit (with 2 knobs and spindles) - AS5122 (white) and AS5626 (beige).

6. INSTALLATION



WARNING - Please note that incorrect installation may invalidate the warranty.
Preparation - Always disconnect power sources before installing.

WARNING

BEFORE installation

1. Check the faucet or shower unit does not obstruct the use of sink covers etc.
2. Check that there is sufficient space below the worktop/sink surface to allow the shower unit hose to retract fully.
3. Check that the hose is not twisted or tangled. If the hose is rigid this can be rectified by placing the hose in a container of hot water for 10 to 15 minutes before installation.
4. For the retractable shower systems, the hose must be contained in an enclosed compartment that facilitates a drainage system.

MOUNTING FOR UNITS WITH A MOUNTING PLATE

1. Position faucet or shower unit and wall bracket to allow shower head to fit into wall bracket when hose is extended.
2. Use template supplied to cut out the main slot or holes required, and to drill the four 2.9 mm diameter screw holes.
3. After plumbing and wiring (if necessary) apply water resistant silicone sealant around the edges of the mounting plate (see Fig.1).
4. Secure mounting plate with screws provided, concealing the screw heads using the screw covers provided (see Fig.2). If required the screw covers are easily removed using a pointed instrument to lever them off.

Note: to ease fitting when microswitches are used, bend the crimp terminals attached to the microswitch inwards until they point vertically downwards.

Fig. 1 Mounting Plate

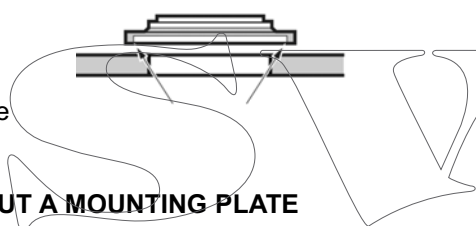
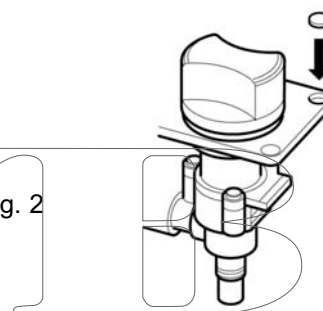

Fig. 2



FOR UNITS WITHOUT A MOUNTING PLATE

1. Position faucet or shower unit and wall bracket to allow shower head to fit into wall bracket when hose is extended.
2. Cut out the holes required.
3. Apply water resistant silicone around each hole before securing.

PLUMBING

Elegance faucets or showers are supplied with either grooved 12mm inlets or 1/2" threaded inlets for use with various pipe systems, see table below.

a) 12mm inlet

Pipe System Used	Fitting required
12mm semi-rigid pipework	Connect directly using Whale Quick Connect 12mm fittings
15mm semi-rigid pipework	Use Whale Quick Connect adaptor WU1215
3/8" (10mm) bore flexible hose	Stainless steel hose clips
1/2" (13mm) bore flexible hose	Use Whale Quick Connect adaptor WX1509 and stainless steel hose clip

b) 1/2" threaded

Connection to Quick Connect 15mm	Use Whale Quick Connect Adaptor(s) WX1532
Connection to 13mm 1/2" flexible hose	Use Whale Quick Connect Adaptor(s) WX1532 WX1584B

Elegance taps or showers can be either:-

1. PRESSURE SWITCHED

Utilising a built-in pressure switch in the caravan / motorhome's inlet socket or pump or an in-line pressure switch in the pipework system.

If using the pressure system, no further wiring of the tap/shower controls is necessary.

2. MICROSWITCHED SYSTEM

(i) The microswitches have a maximum recommended rating of 5 Amps.

(ii) See wiring diagram. (see Fig. 3).

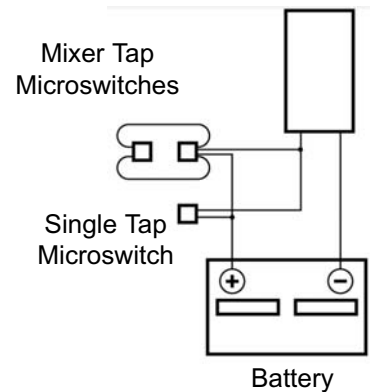

Fig. 3 Microswitch Wiring Diagram

Note: Wires no less than 1 mm² cross sectional area should be used for wiring. It is advisable to fit a fuse of a suitable rating for the pump on the +ve wire up to a maximum of 5 Amps.

OPERATION OF SHOWER UNIT

The shower head can be set in three positions:

- Faucet flow - over sink.
- Shower flow - over shower tray or for rinsing sink.
- Off position - temporarily shuts off the flow to economise on water usage.

IMPORTANT: The OFF position should only be used to shut off the flow temporarily as the shower head is **not** designed to withstand constant pressure. It is not a drip proof seal. This action does not turn the pump off in microswitched systems.

7. MAINTENANCE

Regular inspection is recommended. Replacement components are available from the Whale Stockists (see www.whalepumps.com for details). Microswitches can be removed as follows:

- (i) Turn off power supply.
- (ii) Turn faucet to off position.
- (iii) Remove the crimp terminals.
- (iv) Hold the sides of the microswitch clip with your thumb and finger and gently pull off the clip.
- (v) The microswitch should slide off the two retaining pins. Be careful not to break the pins off (see Fig. 4).

Taps can be dismantled as follows:

- (i) Pull off knob(s) and spindle(s).
- (ii) Unscrew securing screw(s), using a 17mm (11/16") spanner.
- (iii) Control unit(s) can now be released for inspection (see Fig. 5).

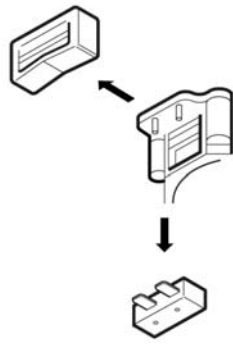

Fig. 4

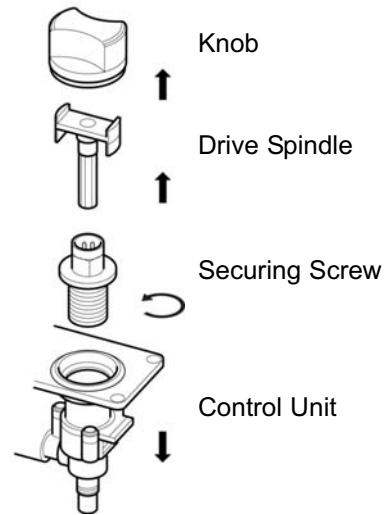

Fig. 5

8. HELPFUL HINTS

Tools required: 17mm ($1\frac{1}{16}$ ") spanner and Posi #6 screwdriver. A piece of insulating or masking tape applied to the mounting surface before marking out the fixing hole will help stop the drill from wandering, especially on tiled surface.

9. WINTERISING

To avoid damage as a result of freezing, drain the entire water system. To protect Elegance Faucet or Shower units, the Faucet Control(s) and the shower handset on/off control should be opened when draining the system to enable stored water in the outlet to drain back through the control valves and out of the system. Ensure that both the hot and cold systems are fully drained, the cold drain plug (if fitted) is a separate drain plug from the heater drain plug. Faucet spouts and shower heads should be unscrewed, removed and stored in a dry place. Please contact Whale Support or visit www.whalepumps.com for a copy of our winterising guide.

10. SERVICE SUPPORT DETAILS

For installation or serviceable parts advice please contact Whale® Customer Support:

Tel: +44 (0)28 9127 0531

Email: info@whalepumps.com
www.whalepumps.com

11. PATENTS AND TRADEMARKS

WHALE®, is a registered trademark of Munster Simms Engineering Limited, Bangor, Northern Ireland also trading as Whale.

12. WARRANTY

This product is protected by a 1 year warranty, for full details of our warranty statement please see enclosed leaflet.

©Copyright Whale 2014 - All rights reserved.

WHALE®, is a registered trademark of Munster Simms Engineering Limited, Bangor, Northern Ireland trading as Whale. Whale's policy is one of continuous improvement and we reserve the right to change specifications without prior notice. Illustrations are for guidance purposes only.

SWIB

SWIB

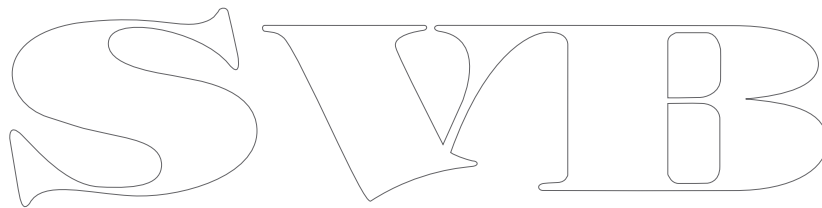

Munster Simms Engineering Ltd.
2 Enterprise Road, Bangor, N. Ireland BT19 7TA
Tel: +44 (0)28 9127 0531 Fax: +44 (0)28 9146 6421
Web: www.whalepumps.com Email: info@whalepumps.com

Munster Simms Engineering Ltd.
91 Manchester Valley Road, P.O. Box 1788, Manchester Center, VT 05255, U.S.A.
Tel: 802 367 1091 Fax: 802 367 1095
Web: www.whalepumps.com Email: usasales@whalepumps.com

Please note that by contacting Whale Support you will be indicating your consent to receiving product updates, recall information, help guides and appropriate marketing messages from us via post, email or telephone unless you indicated an objection to receiving such messages.